



Service Manual

Ultra Heat GMV6 Mini DC Inverter VRF Units

Capacity: 36000Btu/h~60000Btu/h

Rated Frequency: 60Hz

Operation Range: Cooling: -18*~54°C(0*~129°F)
Heating: -30~27°C(-22~81°F)

Contents

Chapter 1 Product	2
1 Unit List.....	2
2 Parameters	2
3 The Range of Production Working Temperature.....	3
Chapter 2 Commissioning	4
1 Commissioning Process.....	4
2 Safety Requirements.....	4
3 Unit Commissioning	5
4 Unit Function Settings	19
Chapter 3 Faults	37
1 Error Indication.....	37
2 Troubleshooting	41
3 Non-fault Type Troubleshooting	163
Chapter 4 Maintenance	166
1 Precautions for Refrigerant Leakage.....	166
2 Vacuum Pumping, Refrigerant Adding.....	166
3 Inspection of Key Parts	169
4 Replacement of Key Unit Parts	198
5 Explosive View and Parts List	209
Appendixes	211
Appendix 1 Temperature Sensor Resistance and Temperature Relationship Table.....	211
Appendix 2 Refrigerant Temperature and Pressure Table	218
Appendix 3 Pressure Sensor Voltage and Pressure Table	219
Appendix 4 Electric Specifications	222
Appendix 5 Circuit Diagram	224
Appendix 6 Schematic Diagram.....	225
Appendix 7 Names and Functions of Components.....	226

Preface

Thank you for purchasing Ultra Heat GMV6 Mini DC Inverter VRF Units. For correct operation, please read this manual carefully.

This manual applies to Ultra Heat GMV6 Mini DC Inverter VRF Units. It clarifies the safety requirements, basic principles and implementation methods in engineering commissioning, troubleshooting, and after-sales maintenance. Relevant professionals must follow the national (local) safety and technical requirements as well as this manual. Failure to do so may result in improper functioning or damage to the air conditioning system, or even personal injury.

Safety Instructions

Warning symbols

Symbols in this document indicate different severities and possibilities.



Indicates an imminently hazardous situation which, if not avoided, will result in death or serious injury.



Indicates a potentially hazardous situation which, if not avoided, could result in death or serious injury.



Indicates a potentially hazardous situation which, if not avoided, may result in minor or moderate injury. Or indicates an unsafe behavior.



Indicates a situation which could result in equipment or property loss.



Indicates helpful tips or additional information.



Indicates a jump connection.

Chapter 1 Product

1 Unit List

1.1 Basic Modules

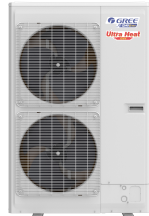
Ton	Product Code	Model	Power	External view
3	CN851W4090	GMV-V36WL/C-T(U)	208/230V ~60Hz	
4	CN850W1220	GMV-V48WL/C-T(U)	208/230V ~60Hz	
5	CN850W1210	GMV-V60WL/C-T(U)	208/230V ~60Hz	

2 Parameters

2.1 Parameters of Basic Modules

Model			GMV-V36WL/C-T(U)	GMV-V48WL/C-T(U)	GMV-V60WL/C-T(U)
Capacity	Cooling	Btu/h	36000	48000	60000
		W	10600	14100	17600
	Heating	Btu/h	36000	48000	60000
		W	10600	14100	17600
Minimum Circuit Ampacity		A	33.8	38.8	38.8
Maximum Overcurrent Protection		A	35	40	40
Power supply		-	208/230V ~60Hz	208/230V ~60Hz	208/230V ~60Hz
Air volume		m ³ /h	6000	6600	6600
		CFM	3531	3885	3885
Sound pressure level		dB(A)	50	52	55
Compressor type		-	Inverter Rotary	Inverter Rotary	Inverter Rotary
Compressor quantity		N	1	1	1
Refrigerant oil model		-	FW68L(FW68DA)	FW68L(FW68DA)	FW68L(FW68DA)
Refrigerant type		-	R410A	R410A	R410A
Refrigerant charge		kg	4.0	4.0	4.4
		LBS	8.8	8.8	9.7
Max. number of connectable IDUs		unit	7	8	10
Gas pipe		mm	Φ15.9	Φ15.9	Φ19.05
		inch	Φ5/8	Φ5/8	Φ3/4
Liquid pipe		mm	Φ9.52	Φ9.52	Φ9.52
		inch	Φ3/8	Φ3/8	Φ3/8
Outline dimensions (W × D × H)		mm	900×340×1345	900×340×1345	900×340×1345
		inch	35-3/8×13-3/8×53	35-3/8×13-3/8×53	35-3/8×13-3/8×53
Packing dimensions (W × D × H)		mm	993×453×1500	993×453×1500	993×453×1500
		inch	39-1/4×18×59-1/16	39-1/4×18×59-1/16	39-1/4×18×59-1/16
Net weight/Gross weight		kg	113/124	113/124	113/124
		LBS	250/270	250/270	250/270

Note:

- ① Sound Pressure Level: Anechoic chamber conversion value, measured in a semi-anechoic room. During actual operation, the value may be higher due to ambient noise and echoes of the installation conditions.
- ② The total capacity of connected indoor units must be in the range of 50%~135% of the outdoor unit capacity. The relevant parameters can be corrected by referring to the unit capacity correction table.
- ③ The above parameters are tested based on the standard connection pipe length. In the actual project, the parameters should be corrected referring to the capacity correction for the long connection pipe of units.
- ④ Specifications may be changed due to product improvement. Please refer to nameplates of the units.

3 The Range of Production Working Temperature

—	Cooling	Heating
Ambient temperature	-18°C*~54°CDB(0*~129°F)	-30°C~27°CDB(-22~81°F)
Indoor temperature	14°C~25°CWB(57~77°F)	15°C~27°CDB(59~80°F)
Indoor humidity	≤80%	

***Note:** Cooling at -18~ -5°C(0~23°F) is conditional. Please inquire our engineers for more information.

Generally, the lowest operating temperature for cooling is -5°C(23°F).

When the indoor units are all VRF fresh air processor, the unit operating range is as follows:

Cooling	Ambient temperature: 16°C(60.8°F)~45°C(113°F)
Heating	Ambient temperature: -7°C(19.4°F)~16°C(60.8°F)

**NOTE!**

If exceeding the temperature range for working, the product may be damaged, which is not within the warranty range.

Chapter 2 Commissioning

WARNING!

Before performing operations (such as commissioning, maintenance, and repair) on the device, you need to shut down the unit and cut off the power, and use a relevant instrument to ensure that the voltage at the power input terminal is zero, and the power indicator on the main board is off. Otherwise, an electric shock or injury may be caused.

NOTE!

The unit features a low-power standby function. When the unit is standby, the power indicators on the main control board and the drive board are on.

1 Commissioning Process

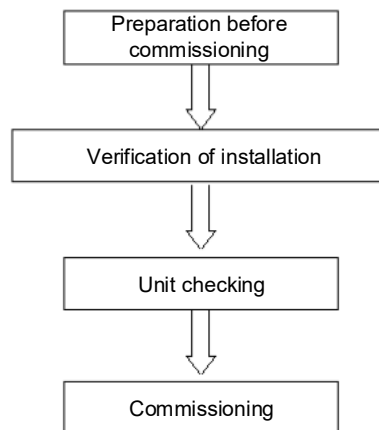

2 Safety Requirements

WARNING!

Safety measures must be taken for outdoor operations. All involved commissioning personnel and maintenance personnel must master the building construction safety regulations and strictly follow them.

Special workers like refrigeration workers, electricians, and welders must hold special work licenses and cannot work on other posts.

When the device is operated, the power of the entire system must be cut off, and the equipment safety requirements must be strictly followed.









All installation and maintenance operations must comply with the product design requirements and national and local safety requirements.

It is strictly forbidden to directly connect the compressor to the power.

3 Unit Commissioning

3.1 Preparation

3.1.1 Tools

Name	Picture
Screwdrivers	
Spanner	
Hex key	
Pincers	
Vacuum pump	
Electronic balance	
Pressure gauge	
Multimeter	

3.1.2 Files

To record the installation and commissioning of the unit, all the following documents need to be prepared: minutes of the pre-commissioning scheme determining meeting, commissioning personnel record form, pre-commissioning checklist, commissioning data record form, and commissioning report.

Minutes of the commissioning scheme determining meeting:

Minutes of the commissioning scheme determining meeting for XXX project:	
Theme:	xxx
Date:	xxx
Place:	xxx
Participants:	xxx
Details:	xxx
1	
2	
3	

Checklist of the commissioning system appearance:

Checklist of the equipment appearance of xxx air-conditioning project				
Item		Defect	Inspector	Time
Refrigerating system	Outdoor unit appearance			
	Indoor unit appearance			
	Copper pipe insulation			
Drainage system	Condensate water pipe insulation			
Electrical system	Power cable diameter			
	Power cable layout			
	Air circuit breaker			
Communication system	Communication cable material			
	Communication cable connection			

Commissioning data record form

Project name:				Unit model:			
Debugger:				Date:			
Rated capacity of the outdoor unit (kW):		Rated capacity of the indoor unit (kW):		Total length of the refrigerant pipe (m):			
Maximum drop between the indoor unit and outdoor unit (m):				Supplemented refrigerant (kg):			
Commissioning status: <input type="checkbox"/> Cooling <input type="checkbox"/> Heating Qty and capacity of indoor units:							
Status Parameter		Unit	Before Startup	30 min	60 min		
Status parameters of the outdoor unit	Outdoor ambient temperature	°C					
	Power voltage	V					
	Frequency	Hz					
	Compressor current	A					
	Discharge temperature	°C					
	High system pressure	°C					
	Low system pressure	°C					
	...						
Parameters of indoor unit 1#	Rated capacity	kW					
	Ambient temperature	°C					
	Air position	Position					
	Temperature at the air outlet	°C					
	Outlet airflow	M/S					
	Noise	dB					
	Drainage pan	—					
Parameters of indoor unit 2#	Rated capacity	kW					
	Ambient temperature	°C					
	Air position	Position					
	Temperature at the air outlet	°C					
	Outlet airflow	M/S					
	Noise	dB					
	Drainage pan	—					

3.2 Check Items after Installation and Test Operation

3.2.1 Check Items after Installation

Check items	Possible conditions due to improper installation	Check
Each part of the unit is installed securely?	Unit may drop, shake or emit noise.	
Gas leakage test is taken or not?	Insufficient cooling (heating) capacity.	
Unit gets proper thermal insulation or not?	There may be condensation and dripping.	
Drainage is smooth or not?	There may be condensation and dripping.	
Is the voltage in accordance with the rated voltage specified on the nameplate?	Unit may have malfunction or components may get damaged.	
Is the electric wiring and pipe connection installed correctly?	Unit may have malfunction or components may get damaged.	
Unit is securely grounded or not?	Electrical leakage.	
Power cord meets the required specification?	Unit may have malfunction or components may get damaged.	
Is the air inlet/outlet blocked?	Insufficient cooling (heating) capacity.	
Length of refrigerant pipe and the charging amount of refrigerant are recorded or not?	The refrigerant charging amount is not accurate.	
Binding pieces on compressor feet are removed or not?	Compressor may get damaged.	

3.2.2 Test Operation and Debugging

NOTICE
(1) After finishing the first installation or replacing the main board of outdoor unit, it is necessary to perform test operation and debugging. Otherwise, unit won't be able to work.
(2) Test operation and debugging must be performed by professional technicians or under the guidance of professional technicians.

3.2.2.1 Prepare the Test Operation and Debugging

- (1) Do not connect power until all installation work is finished.
- (2) All control circuits and wires are correctly and securely connected.
- (3) Check whether unit's appearance and pipeline system has been damaged during transportation.
- (4) Calculate the quantity of refrigerant that needs to be added according to the pipe length. Pre-charge the refrigerant. In case that the required charging quantity is not reached while refrigerant can't be added, record the quantity of refrigerant that still needs to add and complement the quantity during test operation. For details of adding refrigerant during test operation, see below.
- (5) After refrigerant is added, make sure valves of outdoor unit are completely open.
- (6) For the convenience of troubleshooting during debugging, unit shall be connected to a PC with applicable debugging software. Make sure unit's real-time data can be checked through this computer. The installation and connection of debugging software can be found in the Service Manual.
- (7) Before test operation, make sure unit is power on and compressor has been preheated for more than 8 hours. Touch the unit to check whether it's normally preheated. If yes, start test operation. Otherwise, compressor might be damaged.

3.2.2.2 Test Operation and Debugging

Description of test operation procedures and main board display of ODU

Description of each stage of debugging progress			
—	Debugging code		Code meaning and operation method
Progress	LED		
	Code	Display status	
01_Set master unit	A0	ON	System is not debugged, hold main board's SW3 button for 5s to start debugging.
	01	ON	2s later, next step starts.
02_Allocate addresses	02/Ad	Display circularly	System is allocating addresses. 10s later, display as below:
	02/L7	Display circularly	No master indoor unit. Display will be on for 1min, during which master IDU can be set manually. If not, system will set the unit with minimum IP address as the master IDU.
	02/oC	Display circularly	Allocation is finished. 2s later, next step starts.
03_Confirm the quantity of ODU	03/01	Display circularly	System is confirming. 1s later, next step starts.
04_Confirm the quantity of IDU	04/00~16	Display circularly	"00~16" displays the quantity of indoor unit. Confirm the number manually. If the number is not consistent the display one, cut off power of IDU and ODU and check whether communication wire of IDU is correctly connected. After the check, connect power and start debugging from progress 01. If the number is then correct, press main board's SW3 button to confirm. Then the display is as below.
	04/oC	Display circularly	System has confirmed the quantity. 2s later, next step starts.
05_Detect ODU's internal communication and capacity ratio	05/C2	Display circularly	Communication between master ODU and driver has error. Check the communication connection of ODU's main board and drive board. When the error is eliminated, start next step. If power is off during troubleshooting, then restart debugging from progress 01 after power is on.
	05/oC	Display circularly	Communication of master ODU and driver is normal. Unit will display as in the left for 2s and detect the capacity ratio of IDU and ODU. If the ratio is within range, then next step will start 2s later. If the ratio is out of range, unit will display as below.
	05/CH	Display circularly	Rated capacity ratio of IDU is too high. Change the combination way of IDU and ODU to make the ratio within range. And restart debugging from progress 01.
	05/CL	Display circularly	Rated capacity ratio of IDU is too low. Change the combination way of IDU and ODU to make the ratio within range. And restart debugging from progress 01.

Description of each stage of debugging progress			
Progress	Debugging code		Code meaning and operation method
	LED		
	Code	Display status	
06_ Detect outdoor components	06/error code	Display circularly	Outdoor component's error. Besides "06", the other blinking will display the related error code. After errors are eliminated, system will start next step automatically. If power is off during troubleshooting, then restart debugging from progress 01 after power is on.
	06/oC	Display circularly	System detects no error on outdoor component. 10s later, next step starts.
07_ Detect indoor components	07/XX/error code	Display circularly	System detects error on indoor components. XX means the project code of IDU with error, e.g. no.1 IDU has d5 and d6 errors, meanwhile no.3 IDU displays error d6 and d7, then the LED will display "07", "01", "d5", "d6" and "03" circularly. After errors are eliminated, system will start next step automatically. If power is off during troubleshooting, then restart debugging from progress 01 after power is on.
	07/XXXX/error code	Display circularly	If errors occur in IDU which the project code is ≥ 3-digit number, then it will display the 2 big digits of project code first, then the 2 small digits, finally the error code, e.g: L1 error occurs in no.101 IDU, then the LED will display "01", "01" and "L1" circularly. Display method is the same for several IDUs with multiple errors.
	07/oC	Display circularly	No error on components of IDU. 5s later, next step starts.
08_ Confirm preheated compressor	08/U0	Display circularly	Preheat time for compressor is less than 8 hours. Display will be as in the left until the preheat time reaches 8 hours. Press main board's SW3 button to confirm manually that the preheat time has reached 8 hours. Then start next step. (NOTE: Compressor may get damaged if it is started without 8 hours of preheat time)
	08/oC	Display circularly	Compressor has been preheated for 8 hours. 2s later, next step starts.
09_ Refrigerant judgments before startup	09/U4	Display circularly	System is lack of refrigerant and display will be as in the left. Please cut off power of IDU and ODU and check if there is leakage on pipeline. Solve the leakage problem and complement refrigerant into the unit. Then connect power and restart debugging from progress 01. (Note: Before re-charging refrigerant, unit must be power off in case system starts progress 10 automatically) .
	09/oC	Display circularly	Refrigerant is normal and unit will display as in the left for 2s. Then next step starts.
10_ Status judgments of outdoor valves before startup	10/on	Display circularly	Valves of ODU are being inspected. Compressor will start operation for 2min or so and then stop. The opening and closing status of outdoor valves are as below.
	10/U6	Display circularly	Outdoor valves are not fully turned on. Press main board's SW4 button and display shows "09/OC". Then check if the gas and liquid valves of ODU are completely open. After confirmation, press the SW4 button again. Then compressor will start running for about 2min to inspect the status of valves.
	10/oC	Display circularly	Valves status is normal. Unit will display as in the left for 2s and then start next step.

Description of each stage of debugging progress			
Progress	Debugging code		Code meaning and operation method
	LED		
	Code	Display status	
12_ Confirm debugging startup	12/AP	Display circularly	Ready for units to start debugging. Press main board's SW3 button to confirm startup of debugging. 2s later, main board will display as below.
	12/AE	Display circularly	Startup is confirmed. After displaying for 2s, system will choose "15_Cooling debugging" or "16_Heating debugging" according to ambient temperature. If the project requests to add refrigerant but it is not complemented before debugging, then refrigerant can be added in this process through the L-VALVE.
15_ Cooling debugging	15/AC	Display circularly	Debugging for cooling mode. If no malfunction occurs for 50min when compressor is running, then the system is certified as normal. After shutting down the unit for 5s, the system will enter normal standby status.
	15/error code	Display circularly	Malfunction occurs when debugging for cooling mode.
16_ Heating debugging(For heat pump units only)	16/AH	Display circularly	Debugging for heating mode. If no malfunction occurs for 50min when compressor is running, then the system is certified as normal. After shutting down the unit for 5s, the system will enter normal standby status.
	16/error code	Display circularly	Malfunction occurs when debugging for heating mode.
17_ Debugging finished	oF	ON	The entire unit has finished debugging and under standby-by condition.

NOTE!

In commissioning status and before the above commissioning processes are completed, when the SW1 up button and SW4 back button are pressed for over 5 seconds, the system enters non-wired-controller commissioning mode, and no longer detects the communication status between the wired controller and indoor units.

Once the debugging for the complete unit is finished, please set relevant functions for the unit according to the actual functional requirements of the project. Refer to relative technical materials for the detailed operation method. If there is no special requirement, skip this step directly.

When delivery it to the user for operation, explain the precautions to the user.

3.2.3 Unit Commissioning on Commissioning Software

Step 1: Install the commissioning software.

Install the commissioning software on a PC, and connect the monitoring communication cable. (For details, see Gree Debugger.)

Step 2: Power on the indoor and outdoor units.

Power on all indoor and outdoor units. In this case, all modules of the outdoor unit indicate that the unit is in "Not commissioning" status.

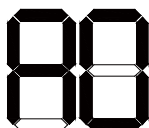

Step 3: Switch the commissioning software to the commissioning control interface.

Click "Debug" to switch to the engineering commissioning interface. The unit will automatically operate the commissioning modules listed in this interface from top to bottom and from left to right. Note: The commissioning function only applies to the single-system network.

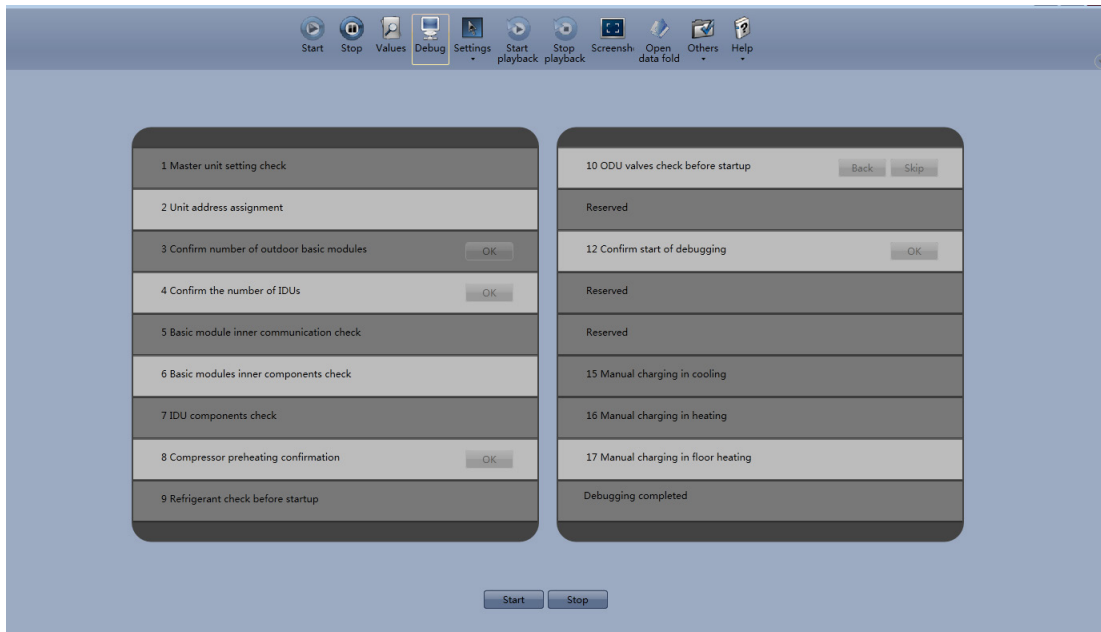

Step 4: Click "Start" to enter the commissioning function

Click "Start" to enter the commissioning function and the software automatically performs commissioning. "🟡" indicates that commissioning is being performed on the phase and "🟢" indicates that commissioning is passed on the phase.

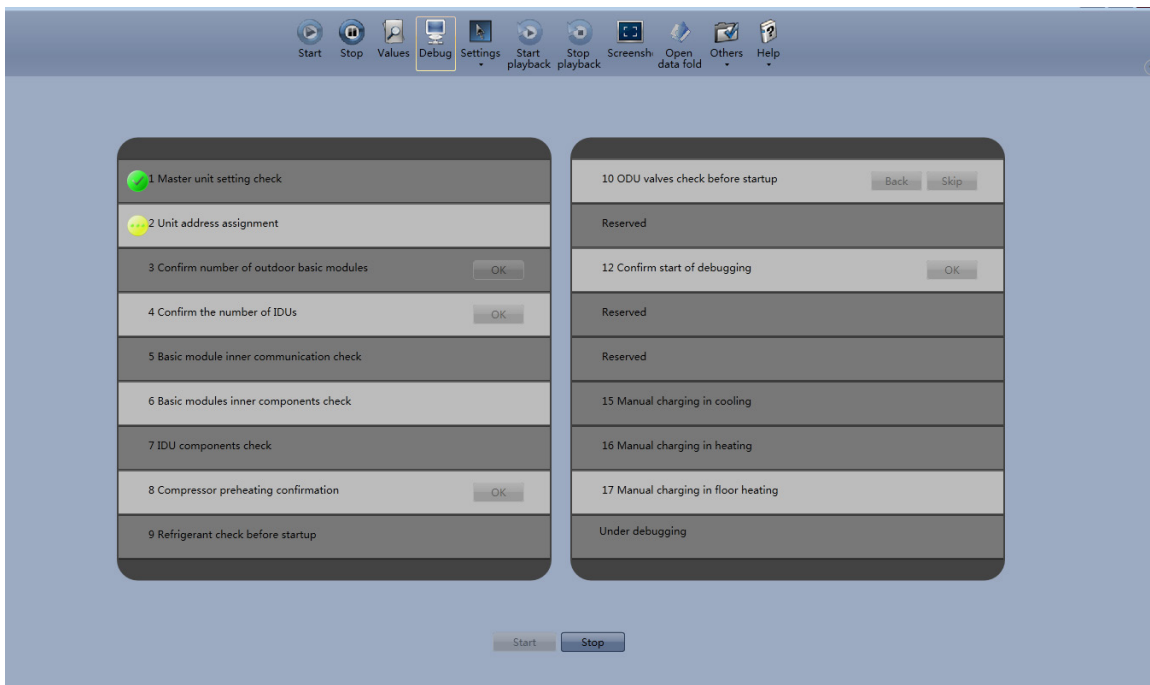

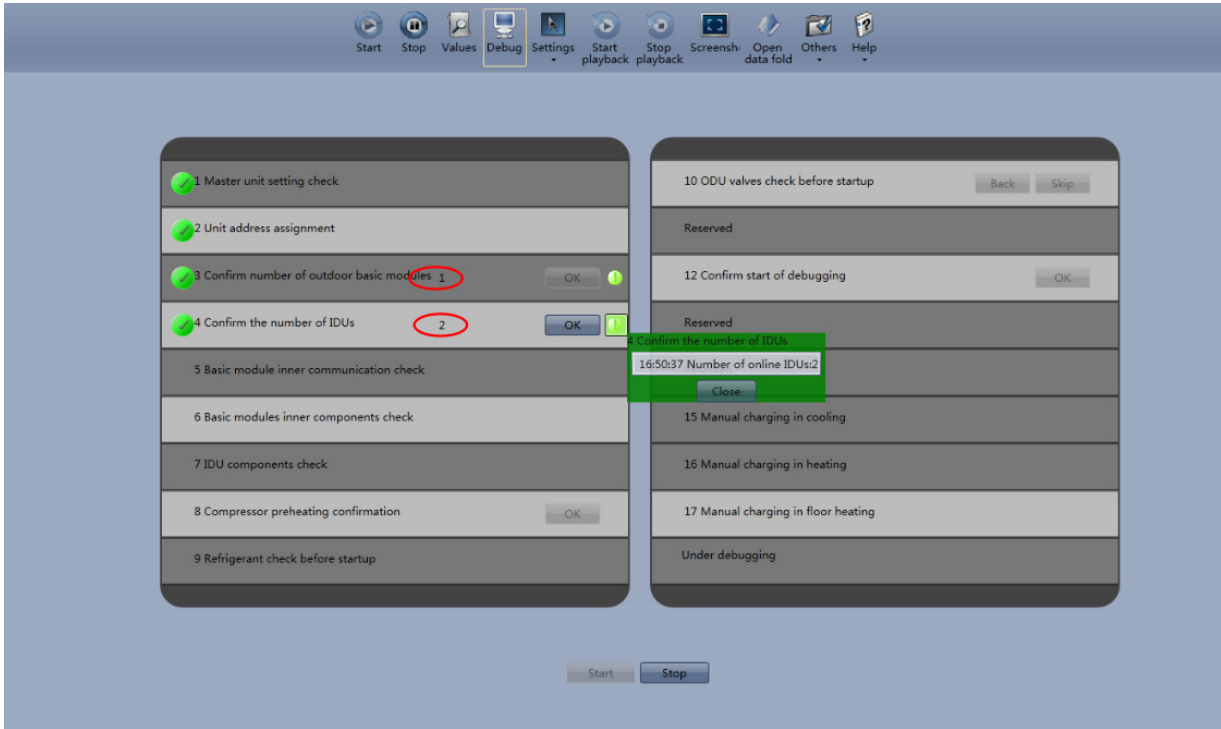

For the phase with "OK" displayed, a manual confirmation is required for entering the next commissioning step. In processes "3 Confirm number of outdoor basic modules" and "4 Confirm the number of IDUs", if the number of online units is consistent with the actual number, click Confirm or wait for 30 seconds to go to the next process. If the displayed number of online units is inconsistent with the actual number in the project, manual check and commissioning again are required for confirmation. Click

"!" to display relevant information detected on this phase, which provides references for selection. Click "Close" to close the information (the number of commissioning units is displayed in "3 Confirm number of outdoor basic modules" and "4 Confirm the number of IDUs", as shown in the red boxes in the figure below.)

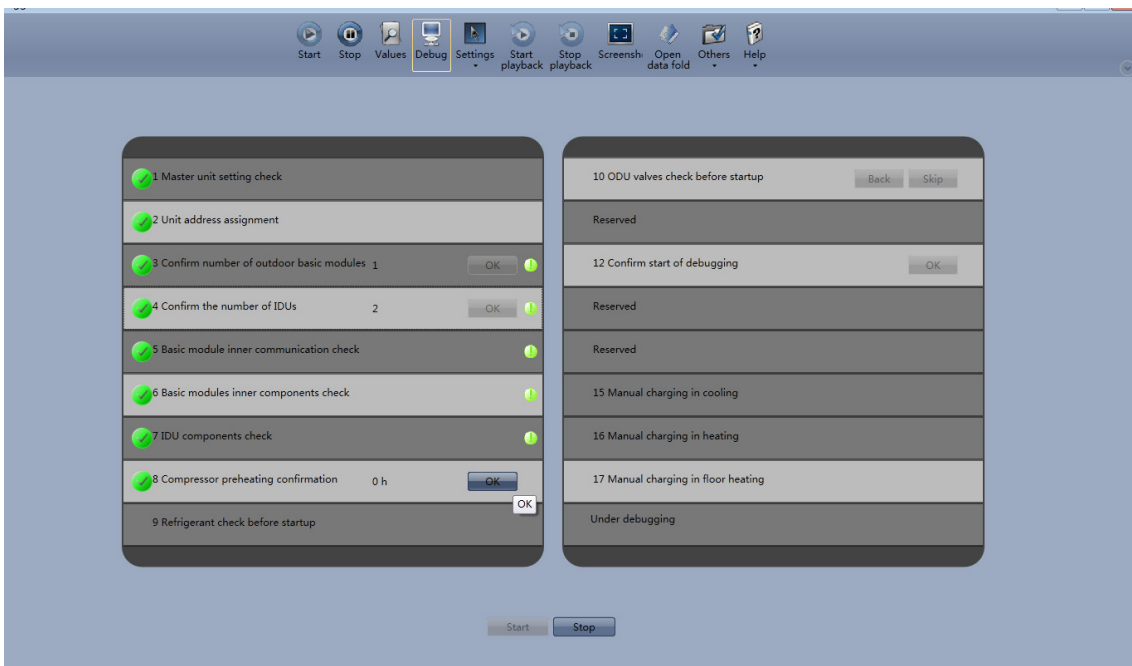

In step "8 Compressor preheating confirmation", the current preheat time is directly displayed, as shown in the red box in the figure below. If the system currently detects that all the basic modules have been continuously powered on for 8 hours or more, or the previous time when the modules were powered on for 8 hours or more is less than 8 hours from the current time, preheat is completed and the system can proceed to the next process. Otherwise, the system prompts UO (insufficient compressor preheat time).



"" indicates that commissioning is not passed on the phase and troubleshooting is required (after troubleshooting, the unit automatically enters the next step if no "OK" exists or click "OK" to enter the next step). Click "" to display relevant information detected on this phase, which provides references for troubleshooting. Click "Close" to close the information.

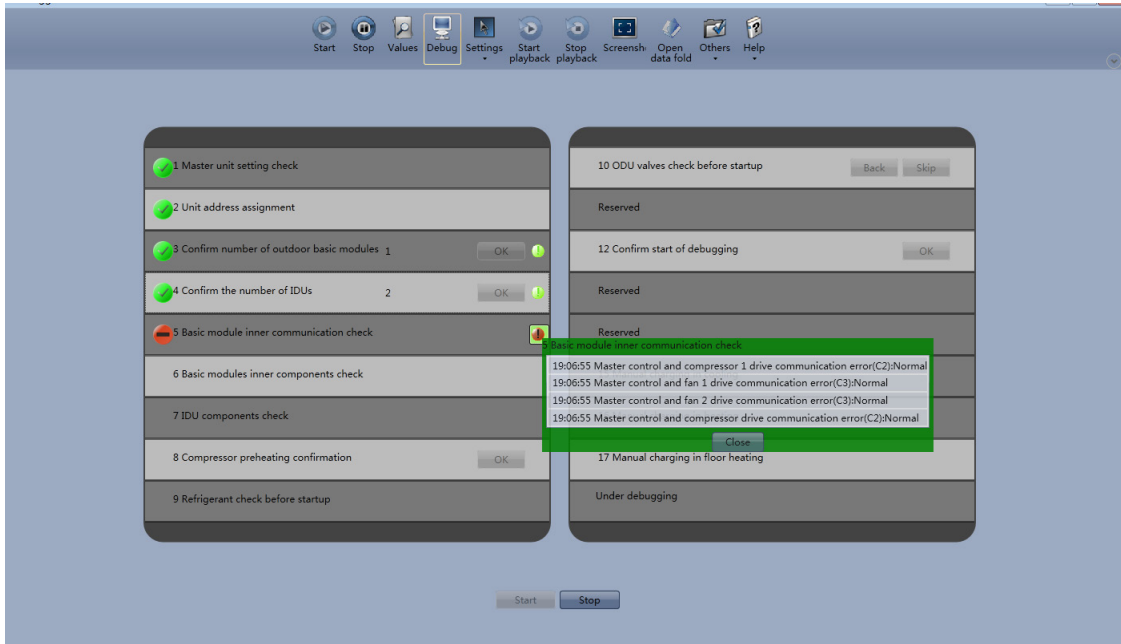

During commissioning, click "Stop" to stop commissioning and then click "Start" to continue commissioning till commissioning ends. "Back" and "Skip" are provided in "10 ODU valves check before startup". When an exception occurs in step 10, click "Back" to return to step 9 and then click "OK" in step 9 to perform commissioning again for step 10. If a U6 fault (valve exception) occurs in step 10, users can click "Skip" to skip the fault. For other faults, "Skip" is unavailable.

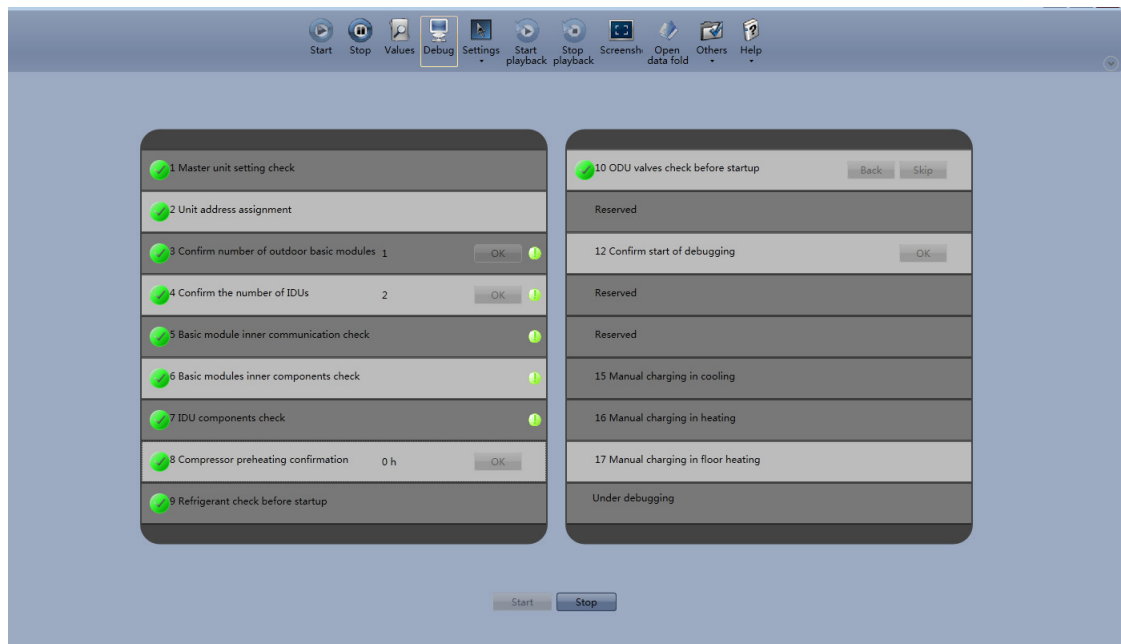

The system automatically enters the stage of confirming the unit start-up and commissioning, with LEDs cyclically displaying "12" and "AP", waiting for confirmation of the unit start-up and commissioning command, and pressing the SW3 confirmation key to confirm the unit start-up and commissioning.

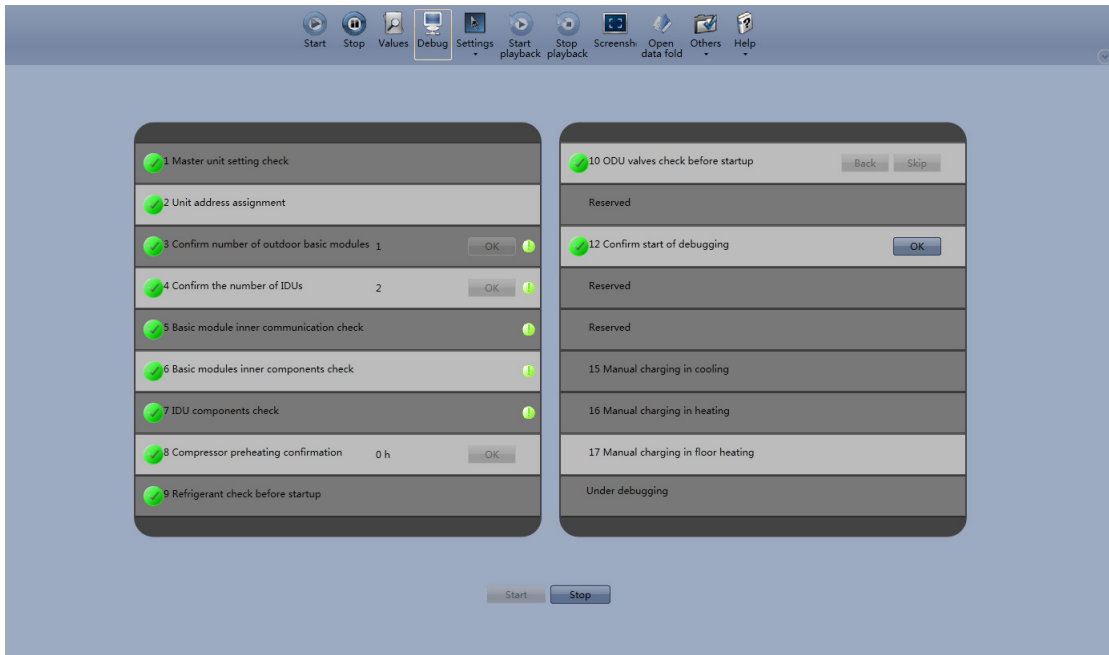

The system automatically enters the unit filling operation stage with "15" and "AE" displayed on the LED cycle. The system automatically selects the commissioning operation mode according to the [average indoor ambient temperature in the system], and the system enters the normal standby state after the engineering commissioning is completed.

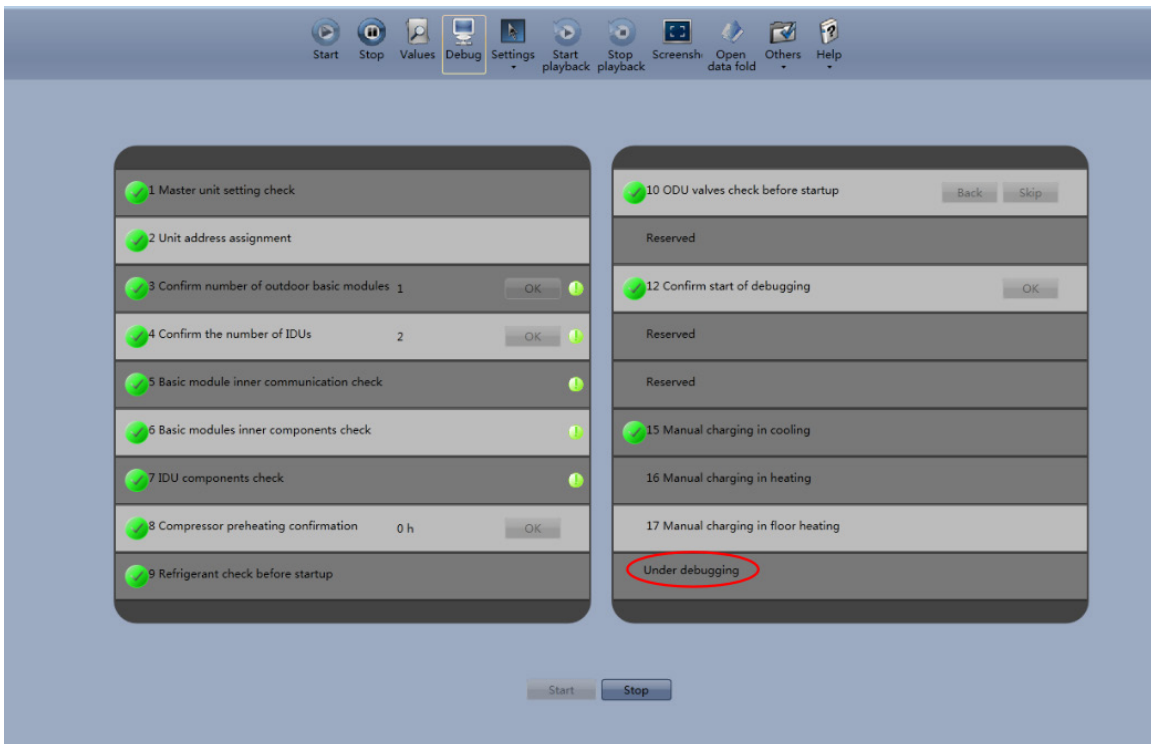

Note:

During commissioning, users must listen to the operating sound of outdoor and indoor fans and compressors to check for exceptions.

3.2.4 Unit Commissioning by Using Multi-functional Debugger

Step 1: Connect multi-functional debugger. For details, see the user manual of multi-functional debugger.

Step 2: Click **Unit Debug** on the home page to enter the commissioning page.

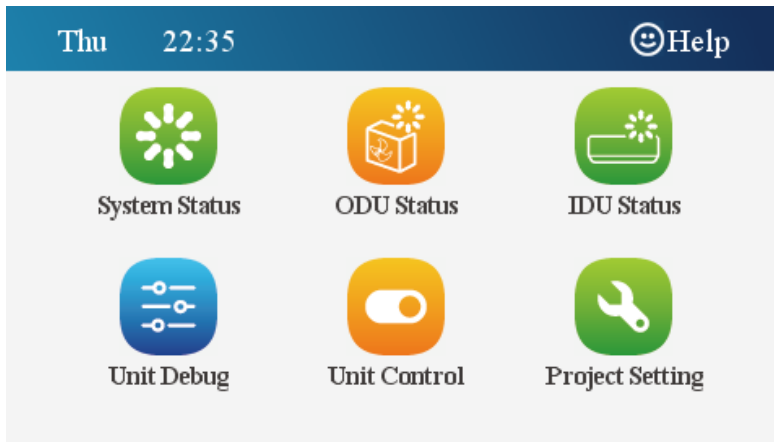

Step 3: On the commissioning page, click **Startup** to start commissioning or click **Stoppage** to stop commissioning.

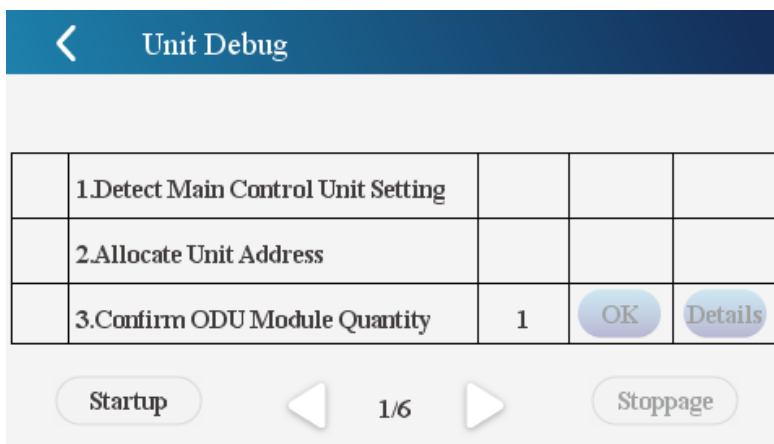

Step 4: During commissioning, multi-functional debugger shows the current process (step). In steps 3, 4, 8, and 12, click Confirm to go to the next step. In step 10, click Skip or Back. In steps 3, 4, 5, 6, and 7, you can view the details.

Step 5: After the commissioning, the outdoor unit displays "OF" (or a fault, if any, or "on" when the unit is started up).

Warning:

After the product is used, the cable connection of the air-conditioner unit must be recovered. Otherwise, the actual use will be affected.

3.2.5 After Commissioning

Organize and save the data. Make complete and detailed records of exceptions and corresponding solutions in the commissioning process for future maintenance and query. Finally, export the commissioning report and hand it over to the user.

After the commissioning, instruct the user of the following precautions:

When the outdoor unit is continuously powered off for more than 24 hours, it must be warmed up for at least 8 hours to avoid damage to the compressor.

3.2.6 Reference Values of Unit Normal Operation Parameters (Commissioning Check)

No.	Debug item		Parameter name	Unit	Reference
1	System parameters	ODU parameters	Outdoor temperature	°C(°F)	—
2			Compressor discharge temperature	°C(°F)	<ul style="list-style-type: none"> When compressor starts, discharge temp in cool mode is within 70~105°C(158~221°F) and at least 10°C(50°F) higher than the high pressure saturation temperature. As for temp in heat mode, it is within 65~90°C(149~194°F) and at least 10°C(50°F) higher than the high pressure saturation temperature.
3			Defrosting temperature	°C(°F)	<ul style="list-style-type: none"> In cool mode, defrosting temperature is 4~10°C(39~50°F) lower than system's high pressure value. In heat mode, defrosting temperature is about 2°C(36°F) different from system's low pressure value.
4			System high pressure	°C(°F)	<ul style="list-style-type: none"> In cool mode, the normal high pressure value is within 20~55°C(68~131°F). According to the change of ambient temperature and system's operating capacity, the high pressure value will be 10~30°C(50~86°F) higher than ambient temperature. The higher ambient temperature is, the smaller temperature difference is. If ambient temp is 25~35°C(77~95°F) in cool mode, system's high pressure value will be within 44~53°C(111~127°F). In heat mode, if ambient temperature is above -5°C(23°F), system's high pressure value is within 40~52°C(104~126°F). If ambient temperature is low and many IDUs are turned on, the high pressure will be lower.
5			System low pressure	°C(°F)	<ul style="list-style-type: none"> When ambient temperature in cool mode is 25~35°C(77~95°F), the low pressure value is 0~8°C(32~46°F). When ambient temperature in heat mode is above -5°C(23°F), the low pressure value is -15~8°C(5~46°F).
6			Opening degree of thermal EXV	PLS	<ul style="list-style-type: none"> In cool mode, the thermal electronic expansion valve remains 480PLS. In heat mode, the adjustable opening degree of EXV is 60~480PLS.
7			Compressor's operating frequency	Hz	Changes in 15Hz~120Hz.
8			Compressor's operating current	A	When compressor works normally, the current is no more than 18A.
9			Compressor's IPM temperature	°C(°F)	When ambient temperature is below 35°C(95°F), IPM temp is lower than 80°C(176°F) and the highest temperature won't be above 95°C(203°F).
10			Fan motor's operating frequency	Hz	Changes in 0~50Hz according to system's pressure.

No.	Debug item		Parameter name	Unit	Reference
11	System parameters	IDU parameters	IDU ambient temperature	°C(°F)	—
12			Indoor heat exchanger's inlet temperature	°C(°F)	<ul style="list-style-type: none"> ● According to ambient temperature, for a same IDU in cool mode, the inlet temp will be 1~7°C(34~45°F) lower than the outlet temperature, and 4~9°C(39~48°F) higher than the low pressure value. ● For a same IDU in heat mode, the inlet temperature will be 10~20°C(50~68°F) lower than the outlet temperature.
13					
14			Opening degree of indoor EXV	PLS	
15	Communication parameters	Communication data	—	Number of IDUs detected by software is the same with the actual number. No communication error.	
16	Drainage system		—	—	Indoor unit can drain water out completely and smoothly. Condensate pipe has no backward slope of water; Water of outdoor unit can be drained completely through drainage pipe. No water drop from unit base.
17	Others		—	—	Compressor and indoor/outdoor fan motor do not have strange noise. Unit can operate normally.

4 Unit Function Settings

4.1 DIP Switch Settings

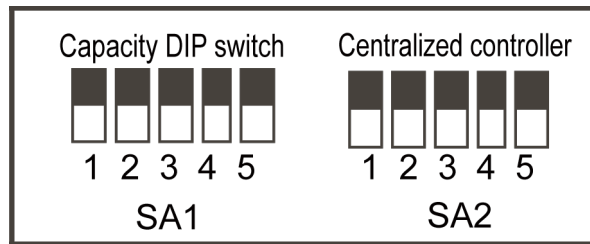

Code	Name	Meaning	Default Setting	Remarks
SA1_capacity	Capacity DIP switch	Defines the rated capacity of the unit.	Depending on the model	The DIP switch is set by the factory and cannot be changed.
SA2_Addr-CC	Address DIP switch for centralized control	Defines and distinguishes addresses of different systems for centralized control of multiple systems.	00000	The code is used only for centralized control. Otherwise, keep the default setting. This address can be set only on the master unit.



NOTES!

- ① The function DIP switches must be set when the outdoor unit is powered off. A DIP switch setting takes effect after the unit is re-powered on.
- ② SA1 DIP switch cannot be changed. The default settings of other DIP switches do not need to be changed if there are no special requirements.

4.1.1 Unit Capacity DIP Switch (SA1_capacity)

This DIP switch is set by the factory before shipment, and cannot be changed. Otherwise, the system will work abnormally and even damage the compressor.

4.1.2 Address DIP Switch for Centralized Control (SA2_Addr-CC)

This DIP switch indicates the address for centralized control of different refrigerating systems. It is set to 0000× by default.

If centralized control is not required between multiple refrigerating systems, keep the default setting of this DIP switch.

If centralized control is required between multiple refrigerating systems, set as follows:

- (1) Be sure to set the DIP switch on the master unit.
- (2) Setting this DIP switch on non-master units in a refrigerating system is invalid and unnecessary.
- (3) Be sure to set the address DIP switch for centralized control (SA2_Addr-CC) on the master unit of a refrigerating system to "0000x". Then, this system is the main system.
- (4) Set the address DIP switch for centralized control (SA2_Addr-CC) on the master units of other refrigerating systems as follows:

SA2					Address No.
DIP1	DIP2	DIP3	DIP4	DIP5	
1	0	0	0	×	2
0	1	0	0	×	3
1	1	0	0	×	4

SA2					Address No.
DIP1	DIP2	DIP3	DIP4	DIP5	
0	0	1	0	×	5
1	0	1	0	×	6
0	1	1	0	×	7
1	1	1	0	×	8
0	0	0	1	×	9
1	0	0	1	×	10
0	1	0	1	×	11
1	1	0	1	×	12
0	0	1	1	×	13
1	0	1	1	×	14
0	1	1	1	×	15
1	1	1	1	×	16

Note:

- ① DIP switch at the ON end indicates 0;
- ② DIP switch at the other end indicates 1;
- ③ × indicates invalid.
- (5) This DIP switch of different refrigerating systems cannot be set the same. Otherwise, an address conflict will occur and the unit will not operate.

4.1.3 DIP switch position description

DIP switch at the ON end indicates 0; DIP switch at the other end indicates 1.

The white lever is DIP switch position.

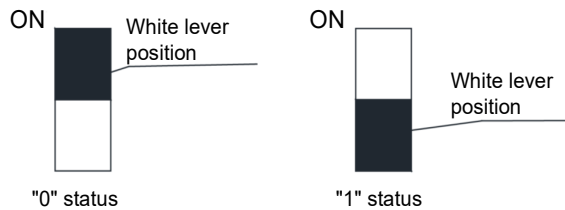

4.2 System Function Operations



CAUTIONS!

- ① System function settings and queries must be performed after the entire system is commissioned.
- ② System function settings and queries can be performed regardless of whether the entire system is running or not.

4.2.1 Function Buttons

There are four function buttons on the main board of the outdoor unit, as shown below:

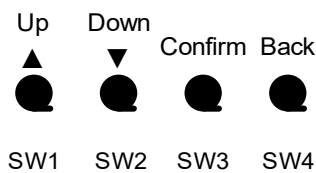

Names and Functions of the Buttons		
Button No.	Code	Function
SW1	Up	Selects the upper item.
SW2	Down	Selects the lower item.
SW3	Confirm	Confirms the selection.
SW4	Back	Returns to the previous operation.

4.2.2 Function Description

Function Code	Function Name	Description	Default Setting		Remarks
			Code	Meaning	
A2	Refrigerant recycle	This function is automatically started during maintenance. Based on the system pressure change, this function recycles all or partial refrigerant of the faulty module or the indoor unit pipeline.	—	—	This function can only be set.
A6	Cooling/heating of the entire system	The unit can be set to cooling and heating, cooling only, heating only, or fan mode for centralized management.	nA	Cooling and heating	This function can be set and queried.
A7	Outdoor silence mode	This function sets different silence modes based on the user's needs.	00	No silence	This function can be set and queried.
A8	After-sales vacuum pumping mode	During maintenance, the system automatically turns on all electronic expansion valves and solenoid valves to ensure that all lines can be vacuumed.	—	—	This function can only be set.
n0	Auto energy saving	This function can automatically reduce power consumption of the unit based on system operating parameters.	01	Capability priority control	This function can be set and queried.
n3	Forced defrosting	This function forcibly enables defrosting of the outdoor unit of the system.	—	—	This function can only be set.
n4	Forced energy saving	This function forcibly reduces the maximum power consumption of the unit.	10	100% capability output	This function can be set and queried.
n5	Indoor unit engineering SN offset	When different refrigerating systems are controlled in a centralized manner, this function avoids the conflict of indoor unit engineering numbers.	—	—	This function can only be set.
C9	Fan emergency setting	—	00	Normal operation of the fan	—

4.2.3 Function Operations

Before setting every function, perform the following steps to select the function you want to set. The following premise steps will not be repeated.

Premise steps for function setting:

Step 1: Power on the entire system.

Step 2: Press and hold the SW1 up button on the unit for over 5 seconds. The system enters the function setting status. The unit displays as follows by default.

LED1	
Function code	Display status
A7	Blinks

Press the SW1 up button and the SW2 down button on the unit to select the corresponding function/parameter:

LED1		Function Name
Function code	Display status	
A7	Blinks	Outdoor unit silence
A6	Blinks	Cooling/heating of the entire system
A2	Blinks	Refrigerant recycle
A8	Blinks	After-sales vacuum pumping
n0	Blinks	Auto energy saving
n3	Blinks	Forced defrosting
n4	Blinks	Forced energy saving
n5	Blinks	Indoor unit engineering SN offset
C9	Blinks	Fan emergency setting

After selecting the function to be set, press the SW3 confirm button to enter the function setting. The unit displays as follows:

Display step1		Display step2		Function Name
LED1		LED1		
Function code	Display status	Current process	Display status	
A7	Blinks	00	Blinks	Outdoor unit silence
A6	Blinks	00	Blinks	Cooling/heating of the entire system
A2	Blinks	00	Blinks	Refrigerant recycle
A8	Blinks	00	On	After-sales vacuum pumping
n0	Blinks	01	Blinks	Auto energy saving
n3	Blinks	00	On	Forced defrosting
n4	Blinks	00	Blinks	Forced energy saving
n5	Blinks	00	On	Indoor unit engineering SN offset
C9	Blinks	00	Blinks	Fan emergency setting

Then, set the function/parameter accordingly.

After entering the function/parameter setting status, press the SW4 back button to return to the previous process or exit the function setting status. If you do not press any button in 5 minutes, the system will automatically exit the current screen and the unit will resume displaying the current status.

4.2.3.1 "A2" Refrigerant Recycle

Introduction:

This function is mainly used to recycle some refrigerant in the fault module and indoor unit pipeline during unit maintenance. The table below lists the maximum amount of refrigerant that can be recycled:

After entering refrigerant recycle, the outdoor unit automatically starts, and recycles the refrigerant to the pipeline of the outdoor unit or indoor unit.

Setting steps:

Step 1: Enter A2 refrigerant recycle, and ensure that the outdoor unit displays as follows:

LED1	
Current process	Display status
01	Blinks

Step 2: When the default value 01 is displayed, press the SW1 up button and the SW2 down button to select the corresponding recycle mode. Press SW3 to confirm the selected mode.

Press the SW4 back button on the master module to return to the previous process or exit the function setting status.

If you do not press any button in 5 minutes, the system will automatically exit the current screen and the unit will resume displaying the current status.

Indoor unit pipeline refrigerant recycle:

Step 3: Select 01 in step 2 to enter indoor unit pipeline refrigerant recycle. The LED1 of outdoor unit display as follows:

LED1	
Current status	Display status
[Module low pressure Ps]	On

LED1 shows the low pressure value of the module. If it is negative, LED1 circularly displays negative value code "nE" and the numerical value every 1 second. For example, for -30, LED3 circularly displays nE for 1 second, and 30.

Step 4: When the system prompts for manual operation of refrigerant recycle, press SW3 on the master unit to confirm refrigerant recycle. The entire system will stop immediately, and cannot be restarted in 10 minutes. After 10 minutes, the system will exit refrigerant recycle, and enter standby status.

Then, press the SW4 back button to return to the previous process to resume the standby status of the entire system. (During setting, press SW4 to return to the previous process. If the setting is completed, press SW4 to resume the unit to the current normal working status.)

Note:

After refrigerant recycle, the system cannot be restarted within 10 minutes.

4.2.3.2 "A6" Cooling/Heating of the Entire System

Introduction:

This function sets the cooling/heating mode of the entire system. Available modes include:

Outdoor Unit Function Mode		Available Indoor Unit Operation Modes
Code	Name	
nA	Cooling and heating	Cooling, dry, heating, and fan (Note: Heating mode cannot run with other modes at the same time.) (Default setting)
nC	Cooling only	Cooling, dry, and fan
nH	Heating only	Heating and fan (Note: Heating mode cannot run with other modes at the same time.)
nF	Fan	Fan

The user or administrator needs to set the mode of the outdoor unit based on the actual usage to avoid conflicts.

Setting steps:

Step 1: Enter A6 cooling/heating setting of the entire system, and ensure that the outdoor unit displays as follows:

LED1	
Current process	Display status
nC	Blinks

Step 2: Press the SW1 up button and the SW2 down button to select the corresponding cooling/heating mode.

LED1	
Current process/mode	Display status
nC	Blinks
nH	Blinks
nA	Blinks
nF	Blinks

Step 3: After selecting the mode, press the SW3 confirm button. The outdoor unit displays as follows:

LED1	
Current process/mode	Display status
nC	On
nH	On
nA	On
nF	On

Press the SW4 back button on the outdoor unit to return to the previous process or exit the function setting status.

The outdoor unit memorizes this setting and does not clear it even upon power failure and power-on again. The default value is nA cooling and heating mode.

4.2.3.3 A7 Outdoor Silence Mode

Introduction:

This function is mainly used in scenarios where the user requires low ambient noise. Smart night silence mode and forced silence mode are available.

In smart night silence mode, need to set timer of outdoor units.

to ensure low-noise operation at night. Smart night silence mode has nine options:

Silence Mode	Code
Mode 1	01
Mode 2	02
Mode 3	03
Mode 4	04
Mode 5	05
Mode 6	06
Mode 7	07
Mode 8	08
Mode 9	09

Note:

In forced silence mode, the system operates in low-noise mode regardless of day or night. This mode has three options:

Silence Mode	Code
Mode 10	10

Silence Mode	Code
Mode 11	11
Mode 12	12
Mode 13	13

Note:

After a silence mode is set, the system capability will be attenuated. Therefore, the noise and the capability need to be balanced when a silence mode is selected.

No silence is set by default, that is, "00" status.

Setting steps:

Step 1: Enter A7 outdoor silence mode, and ensure that the master module displays as follows:

LED1	
Silence mode code	Display status
00	Blinks

Step 2: Press the SW1 up button and the SW2 down button to select the corresponding silence mode.

LED1	
Silence mode code	Display status
00	Blinks
01	Blinks
02	Blinks
03	Blinks
04	Blinks
05	Blinks
06	Blinks
07	Blinks
08	Blinks
09	Blinks
10	Blinks
11	Blinks
12	Blinks
13	Blinks

Step 3: After selecting the corresponding silence mode, press the SW3 confirm button. The outdoor unit displays as follows:

LED1	
Silence mode code	Display status
00	On
01	On
02	On
03	On
04	On
05	On
06	On
07	On
08	On
09	On
10	On
11	On
12	On
13	On

Press the SW4 back button on the master module to return to the previous process or exit the function setting status.

The default status is 00, that is, no silence.

4.2.3.4 A8 After-Sales Vacuum Pumping Mode

Introduction:

This function is used to ensure the vacuum of the entire system during maintenance and to avoid dead pipeline zones. When this function is set, both the expansion valve and the solenoid valve of the unit will open.

Setting steps:

Step 1: Enter A8 after-sales vacuum pumping mode, and ensure that the master module displays as follows:

LED1	
Current process	Display status
00	Blinks

The system enters the to-be-confirmed status of vacuum pumping mode.

Step 2: Press the SW3 button. The system enters the confirmed status of vacuum pumping mode and all modules display as follows:

LED1	
Function code	Display status
A8	On

At this time, the expansion valves of all indoor and outdoor units are open, and the entire system cannot be started.

When you press the SW4 back button on the master unit for over 5 seconds or the vacuum pumping status remains for 24 hours, the entire system exits the status.

4.2.3.5 n0 Auto Energy Saving

Introduction:

This function sets the user-required energy saving mode. The default mode is capability priority control.

After energy saving mode is set, the system capability will deteriorate.

Code	Function Name
01	Capability priority control (default setting)
02	Energy saving priority control

Setting steps:

Step 1: Enter n0 system energy saving operation, and ensure that the outdoor unit displays as follows:

LED1	
Current process/mode	Display status
01	Blinks

Step 2: Press the SW1 up button and the SW2 down button to select the corresponding mode.

LED1	
Current process/mode	Display status
01	Blinks
02	Blinks

Step 3: After selecting the mode, press the SW3 confirm button. The outdoor unit displays as follows:

LED1	
Current process/mode	Display status
01	On
02	On

If you do not press any button on the outdoor unit in 5 minutes, the system will automatically exit the current screen and the unit will resume displaying the current status. (During setting, press SW4 to return to the previous process. If the setting is completed, press SW4 to resume the unit to the current normal working status.)

4.2.3.6 n3 Forced Defrosting

Introduction:

This function is used when forced defrosting is required during unit maintenance. After entering forced defrosting, the system automatically exits according to the exit conditions, and then automatically runs according to the system conditions.

Setting steps:

Step 1: Enter n3 forced defrosting, and ensure that the outdoor unit displays as follows:

LED1	
Current process/mode	Display status
00	Blinks

Step 2: Press the SW3 confirm button. The outdoor unit displays as follows:

LED1	
Function code	Display status
n3	On

If the defrosting condition is not met, the outdoor unit the set mode. If the setting is completed, press SW4 to resume the unit to the current normal working status.

When the defrosting exit condition is met, the system automatically exits and resumes normal running control.

4.2.3.7 n4 Forced Energy Saving Mode

Introduction:

The maximum output capability limit is used in scenarios where the user needs to forcibly limit the system power consumption. Available functions are as follows:

Code	Maximum Output Capability
10	100% (default setting)
09	90%
08	80%

Note:

After the capability limit is set, the cooling or heating effect is correspondingly reduced.

Setting steps:

Step 1: Enter n4 maximum output capability limit setting, and ensure that the outdoor unit displays as follows:

LED1	
Current process/mode	Display status
10 or 09 or 08	Blinks

Step 2: Press the SW1 up button and the SW2 down button to select the corresponding value.

LED1	
Current process/mode	Display status
10	Blinks
09	Blinks
08	Blinks

Step 3: After selecting the value, press the SW3 confirm button. The outdoor unit displays as follows:

LED1	
Current process/mode	Display status
10	On
09	On
08	On

If you do not press any button on the outdoor unit in 5 minutes, the system will automatically exit the current screen and the unit will resume displaying the current status. (During setting, press SW4 to return to the previous process. If the setting is completed, press SW4 to resume the unit to the current normal working status.)

4.2.3.8 n5 Indoor Unit Engineering SN Offset

Introduction:

When different refrigerating systems are controlled in a centralized manner (by remote monitoring or a centralized controller), this function sets the engineering numbers of indoor units and avoids their conflict among different systems, and therefore must be set.

Set this function only in the master system, whose centralized control address SA2 is "0000×". For details, see the settings in section "Address DIP Switch for Centralized Control (SA2_Addr-CC)".

Setting steps:

Step 1: Enter n5 indoor unit engineering SN offset, and ensure that the outdoor unit displays as follows:

LED1	
Current process/mode	Display status
00	Blinks

Step 2: Press the SW3 confirm button to send the engineering number offset instruction. The outdoor unit displays as follows:

LED1	
Function code	Display status
n5	On

After 10s, the system exits the mode and enters normal working.

4.2.3.9 C9 Fan Failure Emergency Operation

This function is after-sales emergency setting when a fan on a dual-fan module works abnormally. It shields the abnormal fan in a short time to ensure the emergency operation of the system.

Setting steps:

Enter the function setting on the main board of the faulty outdoor unit. The outdoor unit displays as follows:

LED1	
Current process	Display status
00	Blinks

Press the SW1 up button and the SW2 down button to select the corresponding fan emergency operation status.

LED1		Description
Current process	Display status	
00	Blinks	Fans 1 and 2 run normally.
01	Blinks	The operation of fan 1 is shielded.
02	Blinks	The operation of fan 2 is shielded.

After selecting the corresponding value, press the SW3 confirm button. outdoor unit display as follows:

LED1	
Mode	Display status
00	On
01	On
02	On

The outdoor unit memorizes this setting and does not clear it even upon power failure and power-on again. The default value is 00.

Then, press the SW4 back button to return to the previous process. (During setting, press SW4 to return to the previous process. If the setting is completed, press SW4 to resume the unit to the current normal working status.)

If you do not press any button in 5 minutes, the system will automatically exit the current screen and the unit will resume displaying the current status.



NOTES!

- ① This function is applicable only to dual-fan models;
- ② A module can set only one fan to emergency mode;
- ③ The default status is 00.
- ④ The system cannot run continuously for more than 120 hours in fan emergency operation status. If it exceeds 120 hours, the entire system is stopped, and the indoor unit displays the limit operation code.

4.2.4 Outdoor Unit Status Query

The following functions can be queried:

Function Code	Function Name
n6	Fault query
n7	Parameter query
n8	Indoor unit engineering SN query
n9	Online indoor unit qty query
nb	Outdoor unit barcode query

After the unit is powered, you can query the function setting status, historical fault record, indoor unit engineering number and real-time parameter of the unit in any status. The query method is as follows:

On the master unit, press and hold the SW2 down button for over 5 seconds. The master unit displays the current function setting status, and other modules display based on their current status. Press the SW1 up button and the SW2 down button on the master unit to select the corresponding query. The default selection is A6.

In function query status, if there are two levels of menus, you can press the SW4 back button to return to the previous level. Press the SW4 query button again to exit query status.

In function query status, if you do not press any button on the master unit in 5 minutes, the system will automatically exit the current screen and the unit will resume displaying the current status.

4.2.4.1 n6 Fault Query

Press the SW1 up button and the SW2 down button to select fault query. The outdoor unit displays as follows:

LED1	
Function Code	Display status
n6	Blinks

Press the SW3 confirm button on the outdoor unit to confirm the selection.

Introduction:

This function is used to query historical faults in the system. Up to five historical faults can be stored in the order of time.

Operations:

In fault query status, press the SW1 up button and the SW2 down button. LED1 circularly displays the code and address of the faulty module in history in the order of time (at an interval of 1s). If there is no historical fault, LED1 display "00" by default. Up to five latest historical faults can be queried. Faults that can be stored and queried are as follows:

1	High pressure protection	20	Inverter compressor over-current protection
2	Low pressure protection	21	Current detection circuit fault of the inverter compressor driver
3	Lack-of-refrigerant protection	22	Loss of synchronization protection for the inverter compressor
4	Air discharge low temperature protection	23	Communication fault between the primary controller and inverter compressor driver
5	Over low pressure ratio protection	24	Over temperature protection for the inverter compressor driver module.
6	Over high pressure ratio protection	25	Temperature sensor fault of the inverter

			compressor driver module.
7	Four-way valve air backflow protection	26	Charging loop fault of the inverter compressor driver.
8	High pressure low protection	27	Under voltage protection for DC bus of the inverter outdoor fan driver
9	High temperature protection for compressor 1	28	Over voltage protection for DC bus of the inverter outdoor fan driver
10	High temperature protection for compressor 2	29	IPM module protection for the inverter outdoor fan driver.
11	Compressor 2 over-current protection	30	Inverter outdoor fan startup failure.
12	Shell roof high temperature protection for compressor 1	31	Inverter outdoor fan phase loss protection.
13	Shell roof high temperature protection for compressor 2	32	Inverter outdoor fan driver module reset.
14	Under voltage protection for the DC bus of inverter compressor driver	33	Inverter outdoor fan over-current protection.
15	Over voltage protection for DC bus of the inverter compressor driver.	34	Current detection circuit fault of the inverter outdoor fan driver.
16	IPM module protection for the inverter compressor driver.	35	Loss of synchronization protection for the inverter outdoor fan.
17	Inverter compressor startup failure	36	Communication fault between the primary controller and inverter outdoor fan driver.
18	Inverter compressor phase loss protection.	37	Over temperature protection for the inverter outdoor fan driver module.
19	Inverter compressor driver module reset.	38	Temperature sensor fault of the inverter outdoor fan driver module.

The figure below shows the Debug page.

LED1	
Current status	Display status
Historical fault/module address	Alternated
	Alternated
	Alternated
	Alternated
	Alternated

If historical faults are less than five, after the last fault is displayed, LED1 display 00, indicating no more fault.

In fault query status, press and hold the SW3 confirm button for over 5 seconds to clear all historical faults of the outdoor unit.

4.2.4.2 n7 Parameter Query

Press the SW1 up button and the SW2 down button to select parameter query. The outdoor unit displays as follows:

LED1	
Function Code	Display status
n7	Blinks

Press the SW3 confirm button on the outdoor unit to confirm the selection.

Introduction:

This function is used to query running parameters of each module of the outdoor unit in real time.

Operations:

In parameter query status, the outdoor unit displays as follows:

LED1	
Function Code	Display status
n7	On

Press the SW1 up button and the SW2 down button to select the corresponding query module, and press the SW3 confirm button. The unit displays as follows:

LED1	
Function Code	Display status
module	On

LED1 displays the module parameter code and the specific value. The parameters and display sequence are listed below. "Outdoor ambient temperature (master module)" is displayed by default. Press the SW1 up button and the SW2 down button to select the corresponding query parameter value.

Parameter Code	Parameter Name	Remarks
01	Outdoor ambient temperature	Outdoor ambient temperature of the outdoor unit is used.
02	Operating frequency of compressor 1	—
03	Operating frequency of compressor 2	—
04	Operating frequency of the outdoor fan	Operating frequency of outdoor fan 1 is used.
05	Module high pressure	Temperature value corresponding to the pressure
06	Module low pressure	Temperature value corresponding to the pressure
07	Discharge temperature of compressor 1	The air discharge pipe temperature is used.
08	Discharge temperature of compressor 2	The air discharge pipe temperature is used.
09	Discharge temperature of compressor 3	—
10	Discharge temperature of compressor 4	—
11	Discharge temperature of compressor 5	—
12	Discharge temperature of compressor 6	—
13	Operating frequency of compressor 3	—
14	Current of compressor 1	The integer value is used, and the wired controller does not query.
15	Current of compressor 2	The integer value is used, and the wired controller does not query.
16	Current of compressor 3	The integer value is used, and the wired controller does not query.
17	Current of compressor 4	The integer value is used, and the wired controller does not query.
18	Current of compressor 5	The integer value is used, and the wired controller does not query.
19	Current of compressor 6	The integer value is used, and the wired controller does not query.
20	Reserved	—
21	Module temperature of compressor 1	The wired controller does not query.
22	Module temperature of compressor 2	The wired controller does not query.
23	Module temperature of outdoor fan 1	The wired controller does not query.
24	Module temperature of outdoor fan 2	The wired controller does not query.
25	Outdoor unit heating EEV 1	The displayed value is the integer value of the actual value divided by 10.
26	Outdoor unit heating EEV 2	The displayed value is the integer value of the actual value divided by 10.
27	Subcooler EEV	The displayed value is the integer value of the actual value divided by 10.
28	Defrost temperature	Defrost temperature 1 is used.
29	Subcooler's liquid outlet temperature	—

Parameter Code	Parameter Name	Remarks
30	Outlet temperature of accumulator	—
31	Oil return temperature	—
32	Inlet pipe temperature of the condenser	—
33	Outlet pipe temperature of the condenser	—

Note:

If a parameter value is negative, LED1 circularly displays negative value code "nE" and the numerical value every 1 second. For example, for -30, LED1 circularly displays nE for 1 second, and 30.

Discharge temperature and ambient temperature values are in four digits. The LED1 circularly displays the left two digits and then the right two digits. For example, 01 and 15 indicate 115 degrees, while nE, 00, and 28 indicate -28 degrees.

If a parameter is invalid on the unit, value "00" is displayed.

If there are two levels of menus on the outdoor unit, you can press the SW4 back button to return to the previous level. Press the SW4 query button again to exit query status.

If you do not press any button on the master unit in 5 minutes, the system will automatically exit the current screen and the unit will resume displaying the current status.

4.2.4.3 n8 Indoor Unit Engineering SN Query

Introduction:

This function makes all indoor units display their SN respectively by performing an operation on the outdoor unit, facilitating indoor unit address query.

Operations:

Press the SW1 up button and the SW2 down button to select indoor unit engineering SN query. The outdoor unit displays as follows:

LED1	
Function Code	Display status
n8	Blinks

Press the SW3 confirm button on the outdoor unit to confirm the selection. The outdoor unit displays as follows:

LED1	
Function Code	Display status
n8 or 00	On

At this time, regardless of the current display status of all indoor unit wired controllers or display panels, all of them switch to display the engineering number of the internal unit, without affecting the setting and operation status of the indoor units and the outdoor unit.

Press the SW4 back button on the outdoor unit to return to the upper operation level, but the indoor units remains displaying the engineering numbers.

Press and hold the SW4 back button on the master unit for over 5 seconds to make all indoor units exit displaying the engineering numbers and return to the upper operation level.

If you do not press any button on the master unit to exit indoor unit engineering SN query in 30

minutes, the system will automatically exit the current screen and the unit will resume displaying the current status.

4.2.4.4 n9 Online Indoor Unit Qty Query

Introduction:

This function directly uses the outdoor unit to query the quantity of online indoor units.

Operations:

In n9 online indoor unit qty query status, the module displays as follows:

LED1	
Function Code	Display status
n9/ quantity,	On

LED1 circularly displays the code and quantity, For example, if the indoor unit quantity is 75, 75 is displayed.

If there are two levels of menus on the outdoor unit, you can press the SW4 back button to return to the previous level. Press the SW4 query button again to exit query status.

If you do not press any button on the outdoor unit in 5 minutes, the system will automatically exit the current screen and the unit will resume displaying the current status.

Note:

This function can query the quantity of indoor units only on a single-system network.

4.2.4.5 nb Outdoor Unit Barcode Query

Introduction:

This function queries the barcodes of the outdoor unit and controller.

Operations:

Press the SW1 up button and the SW2 down button to select outdoor unit barcode query. The outdoor unit displays as follows:

LED1	
Function Code	Display status
nb	Blinks

Press the SW3 confirm button on the outdoor unit to enter the next level of menu. The unit displays as follows:

LED1	
Function Code	Display status
nb	On

Press the SW1 up button and the SW2 down button to select the corresponding query module, and press the SW3 confirm button. The unit displays as follows:

LED1	
Parameter Code	Display status
Un/Pc	Blinks

Note:

Un indicates the unit barcode, while Pc indicates the controller barcode.

After confirming the module, press the SW1 up button and the SW2 down button to select the barcode sequence. The displayed sequence is as follows:

Unit barcode digits 1–13, controller barcode digits 1–13, that is, unit barcode head, unit barcode (digits 1–6), unit barcode (digits 7–12), unit barcode (digit 13), controller barcode head, controller barcode (digits 1–6), controller barcode (digits 7–12), controller barcode (digit 13). The LED display as follows:

LED1	
Parameter code	Display status
Barcode	Blinks

If a parameter is invalid on the unit, value "00" is displayed.

If there are two levels of menus on the outdoor unit, you can press the SW4 back button to return to the previous level. Press the SW4 query button again to exit query status.

If you do not press any button on the outdoor unit in 5 minutes, the system will automatically exit the current screen and the unit will resume displaying the current status.

4.3 Restoration to Default Settings

Restoration to default settings 1 (clearing all settings)

On the main board of the master unit, press and hold the SW1 up button and SW4 back button for over 10 seconds to restore the system default settings. The unit display as follows:

LED1	
Status code	Display status
0C	Blinks for 3 seconds

At this time, the system clears all settings, including engineering numbers of the indoor and outdoor units, quantities of the indoor and outdoor units, and commissioning completion status.

Restoration to default settings 2 (clearing all settings except the commissioning status)

On the main board of the master unit, press and hold the SW2 down button and SW4 back button for over 10 seconds to clear all the system settings. The unit display as follows:

LED1	
Status code	Display status
0C	Blinks for 5 seconds

At this time, the system clears all settings, including engineering numbers of the indoor and outdoor units, but stores quantities of the indoor and outdoor units, and commissioning completion status.

Restoration to default settings 3 (clearing only function settings of the outdoor unit)

On the main board of the master unit, press and hold the SW3 back button and SW4 back button for over 10 seconds to clear all the system settings. The unit display as follows:

LED1	
Status code	Display status
0C	Blinks for 7 seconds

At this time, the system clears all settings, but stores engineering numbers of the indoor and outdoor units, quantities of the indoor and outdoor units, and commissioning completion status.

4.4 Fire Alarm Function Setting

The VRF unit system reserves a fire alarm interface "CN44", which connects with the external fire alarm system. In case of an external fire, the unit urgently shuts down for protection based on the received signal. Then, the unit enters the standby status.

4.5 Indoor Unit Function Applications

For details, see the service manual of the indoor unit.

Chapter 3 Faults

1 Error Indication

—	Error Code	Content	Error Code	Content
Indoor	L0	Malfunction of IDU	L1	Protection of indoor fan
	L2	Auxiliary heating protection	L3	Water-full protection
	L4	Abnormal Power for wired controller	L5	Freeze prevention protection
	L6	Mode conflict	L7	No main IDU
	L8	Power is insufficient	L9	For single control over multiple units, number of IDU is inconsistent (HBS network)
	LA	For single control over multiple units, IDU series is inconsistent (HBS network)	LH	Alarm due to bad air quality
	LC	IDU is not matching with outdoor unit	LL	Malfunction of water flow switch
	LE	Rotation speed of EC DC water pump is abnormal	LF	Malfunction of shunt valve setting
	LJ	Setting of functional DIP switch code is wrong	LP	Zero-crossing malfunction of PG motor
	LU	Zero-crossing malfunction of PG motor	Lb	For single control over multiple units, IDU is inconsistent (reheating-dehumidifying system)
	d1	Indoor PCB is poor	d2	Malfunction of lower water temperature sensor of water tank
	d3	Malfunction of ambient temperature sensor	d4	Malfunction of entry-tube temperature sensor
	d5	Malfunction of mid-tube temperature sensor	d6	Malfunction of exit-tube temperature sensor
	d7	Malfunction of humidity sensor	d8	Malfunction of water temperature sensor
	d9	Malfunction of jumper cap	dA	Web address of IDU is abnormal
	dH	PCB of wired controller is abnormal	dC	Setting capacity of DIP switch code is abnormal
	dL	Malfunction of air outlet temperature sensor	dE	Malfunction of indoor CO ₂ sensor
	dF	Malfunction of upper water temperature sensor of water tank	dJ	Malfunction of backwater temperature sensor
	dP	Malfunction of inlet tube temperature sensor of generator	dU	Malfunction of drainage pipe temperature sensor of generator
	db	Debugging status	dd	Malfunction of solar power temperature sensor
	dn	Malfunction of swing parts	dy	Malfunction of water temperature sensor
	y1	Malfunction of entry-tube temperature sensor 2	y2	Malfunction of exit-tube temperature sensor 2
	y7	Malfunction of fresh air inlet temperature sensor	y8	Malfunction of IDU's air box sensor
	yA	Malfunction of IFD	o1	Low bus bar voltage of IDU
	o2	High bus bar voltage of IDU	o3	IPM module protection of IDU
	o4	Failure startup of IDU	o5	Over-current protection of IDU
	o6	Current detection circuit malfunction of IDU	o7	Desynchronizing protection of IDU
	o8	Communication malfunction of IDU's drive	o9	Communication malfunction of main mater of IDU
	oA	High temperature of IDU's module	ob	Malfunction of temperature sensor of IDU's module
	oC	Charging circuit malfunction of IDU	o0	Other drive malfunction

—	Error Code	Content	Error Code	Content
Outdoor	E0	Malfunction of ODU	E1	High-pressure protection
	E2	Discharge low-temperature protection	E3	Low-pressure protection
	E4	High discharge temperature protection of compressor	Ed	Drive IPM low temperature protection
	F0	Main board of ODU is poor	F1	Malfunction of high-pressure sensor
	F3	Malfunction of low-pressure sensor	F5	Malfunction of discharge temperature sensor of compressor 1
	F6	Malfunction of discharge temperature sensor of compressor 2	F7	Malfunction of discharge temperature sensor of compressor 3
	F8	Malfunction of discharge temperature sensor of compressor 4	F9	Malfunction of discharge temperature sensor of compressor 5
	FA	Malfunction of discharge temperature sensor of compressor 6	FC	Current sensor of compressor 2 is abnormal
	FL	Current sensor of compressor 3 is abnormal	FE	Current sensor of compressor 4 is abnormal
	FF	Current sensor of compressor 5 is abnormal	FJ	Current sensor of compressor 6 is abnormal
	FP	Malfunction of DC motor	FU	Malfunction of casing top temperature sensor of compressor 1
	Fb	Malfunction of casing top temperature sensor of compressor 2	Fd	Malfunction of exit tube temperature sensor of mode exchanger
	Fn	Malfunction of inlet tube temperature sensor of mode exchanger	J0	Protection for other modules
	J1	Over-current protection of compressor 1	J2	Over-current protection of compressor 2
	J3	Over-current protection of compressor 3	J4	Over-current protection of compressor 4
	J5	Over-current protection of compressor 5	J6	Over-current protection of compressor 6
	J7	Gas-mixing protection of 4-way valve	J8	High pressure ratio protection of system
	J9	Low pressure ratio protection of system	JA	Protection because of abnormal pressure
	JC	Water flow switch protection	JL	Protection because high pressure is too low
	JE	Oil-return pipe is blocked	JF	Oil-return pipe is leaking
	b1	Malfunction of outdoor ambient temperature sensor	b2	Malfunction of defrosting temperature sensor 1
	b3	Malfunction of defrosting temperature sensor 2	b4	Malfunction of liquid outlet temperature sensor of sub-cooler
	b5	Malfunction of gas outlet temperature sensor of sub-cooler	b6	Malfunction of inlet tube temperature sensor of vapor liquid separator
	b7	Malfunction of exit tube temperature sensor of vapor liquid separator	b8	Malfunction of outdoor humidity sensor
	b9	Malfunction of gas temperature sensor of heat exchanger	bA	Malfunction of oil-return temperature sensor 1
	bH	Clock of system is abnormal	bE	Malfunction of inlet tube temperature sensor of condenser
	bF	Malfunction of outlet tube temperature sensor of condenser	bJ	High-pressure sensor and low-pressure sensor are connected reversely
	bP	Malfunction of temperature sensor of oil-return 2	bU	Malfunction of temperature sensor of oil return 3
	bb	Malfunction of temperature sensor of oil return 4	bd	Malfunction of gas inlet temperature sensor of sub-cooler
	bn	Malfunction of liquid inlet temperature sensor of sub-cooler	P0	Malfunction of driving board of compressor
	P1	Driving board of compressor operates abnormally	P2	Voltage protection of driving board power of compressor
	P3	Reset protection of driving module of compressor	P4	Drive PFC protection of compressor

—	Error Code	Content	Error Code	Content	
Outdoor	P5	Over-current protection of inverter compressor	P6	Drive IPM module protection of compressor	
	P7	Malfunction of drive temperature sensor of compressor	P8	Drive IPM high temperature protection of compressor	
	P9	Desynchronizing protection of inverter compressor	PA	Malfunction of drive storage chip of compressor	
	PH	High-voltage protection of compressor's drive DC bus bar	PC	Malfunction of current detection circuit drive of compressor	
	PL	Low voltage protection for DC bus bar of drive of compressor	PE	Phase-lacking of inverter compressor	
	PF	Malfunction of charging loop of driven of compressor	PJ	Failure startup of inverter compressor	
	PP	AC current protection of inverter compressor	PU	AC input voltage of drive of inverter compressor	
	H0	Malfunction of driving board of fan	H1	Driving board of fan operates abnormally	
	H2	Voltage protection of driving board power of fan	H3	Reset protection of driving module of fan	
	H4	Drive PFC protection of fan	H5	Over-current protection of inverter fan	
	H6	Drive IPM module protection of fan	H7	Malfunction of drive temperature sensor of fan	
	H8	Drive IPM high temperature protection of fan	H9	Desynchronizing protection of inverter fan	
	HA	Malfunction of drive storage chip of inverter outdoor fan	HH	High-voltage protection of fan's drive DC bus bar	
	HC	Malfunction of current detection circuit of fan drive	HL	Low voltage protection of bus bar of fan drive	
	HE	Phase-lacking of inverter fan	HF	Malfunction of charging loop of fan drive	
	HJ	Failure startup of inverter fan	HP	AC current protection of inverter fan	
	HU	AC input voltage of drive of inverter fan	G0	PV reversed connection protection	
	G1	PV anti-islanding protection	G2	PV DC overcurrent protection	
	G3	PV power generation overload	G4	PV leakage current protection	
	G5	Phase-lacking protection at power grid side	G6	PV LVRT	
	G7	Grid over/under frequency protection	G8	Overcurrent protection at power grid side	
	G9	Drive IPM module protection at power grid side	GA	Low/high input voltage protection at power grid side	
	GH	Photovoltaic DC/DC protection	GC	Photovoltaic DC hardware overcurrent protection	
	GL	Grid side hardware overcurrent protection	GE	High or low photovoltaic voltage protection	
	GF	DC bus neutral-point potential unbalance protection	GJ	Grid side module high-temperature protection	
	GP	Grid side temperature sensor protection	GU	Charging circuit protection	
	Gb	Grid side relay protection	Gd	Grid side current side protection	
	Gn	Insulation resistance protection	Gy	Power protection (PV)	
	Debugging	U0	Preheat time of compressor is insufficient	U2	Wrong setting of ODU's capacity code/jumper cap
		U3	Power phase sequence protection	U4	Refrigerant-lacking protection
		U5	Wrong address for driving board of compressor	U6	Alarm because valve is abnormal
		U8	Malfunction of pipeline for IDU	U9	Malfunction of pipeline for ODU
UC		Setting of main IDU is succeeded	UL	Emergency operation DIP switch code of compressor is wrong	
UE		Charging of refrigerant is invalid	UF	Identification malfunction of IDU of mode exchanger	

—	Error Code	Content	Error Code	Content
Debugging	Ud	Drive board of grid-connection is abnormal	Un	Communication malfunction between the drive board of grid-connection and the main board
	Uy	PV module over-temperature protection	C0	Communication malfunction between IDU, ODU and IDU's wired controller
	C1	Communication malfunction between main control and DC-DC controller	C2	Communication malfunction between main control and inverter compressor driver
	C3	Communication malfunction between main control and inverter fan driver	C4	Malfunction of lack of IDU
	C5	Alarm because project code of IDU is inconsistent	C6	Alarm because ODU quantity is inconsistent
	C7	Abnormal communication of converter	C8	Emergency status of compressor
	C9	Emergency status of fan	CA	Emergency status of module
	CH	Rated capacity is too high	CC	No main unit
	CL	The matching ratio of rated capacity for IDU and ODU is too low	CE	Communication malfunction between mode exchanger and IDU
	CF	Malfunction of multiple main control units	CJ	Address DIP switch code of system is shocking
	CP	Malfunction of multiple wired controller	CU	Communication malfunction between IDU and the receiving lamp
	Cb	Overflow distribution of IP address	Cd	Communication malfunction between mode exchanger and ODU
	Cn	Malfunction of network for IDU and ODU of mode exchanger	Cy	Communication malfunction of mode exchanger
Status	A0	Unit waiting for debugging	A2	Refrigerant recovery operation of after-sales
	A3	Defrosting	A4	Oil-return
	A6	Heat pump function setting	A7	Quiet mode setting
	A8	Vacuum pump mode	A9	Set Back function
	AH	Heating	AC	Cooling
	AL	Charge refrigerant automatically	AE	Charge refrigerant manually
	AF	Fan	AJ	Cleaning reminding of filter
	AP	Debugging confirmation when starting up the unit	AU	Long-distance emergency stop
	Ab	Emergency stop of operation	Ad	Limit operation
	An	Child lock status	Ay	Shielding status
	n0	SE operation setting of system	n1	Defrosting cycle K1 setting
	n3	Compulsory defrosting	n4	Limit setting for max. capacity/output capacity
	n5	Compulsory excursion of engineering code of IDU	n6	Inquiry of malfunction
	n7	Inquiry of parameters	n8	Inquiry of project code of IDU
	n9	Check quantity of IDU on line	nA	Heat pump unit
	nH	Heating only unit	nC	Cooling only unit
	nE	Negative code	nF	Fan model
	nJ	High temperature prevention when heating	nU	Eliminate the long-distance shielding command of IDU
	nb	Bar code inquiry	nn	Length modification of connection pipe of ODU
	qA	Heat recovery status	qH	Mainly heating
qC	Mainly cooling	qP	Export region setting for PV VRF units	
qU	Grid voltage configuration	-	-	

2 Troubleshooting



When troubleshooting the modular units, make sure that all outdoor units are powered off and powered on at the same time. Avoid doing so to only some of the outdoor units.

2.1 "A0" Unit's to-be-commissioned State

Fault display: main board of outdoor unit, wired controller of indoor unit and receiver of indoor unit

display 

Fault diagnosis:

This is a status code. It is displayed before the completion of system engineering commissioning. At this time, the unit cannot be started.

Possible causes: --

Troubleshooting: not required.

2.2 "A2" Refrigerant Recycle Running State

Fault display: main board of outdoor unit, wired controller of indoor unit and receiver of indoor unit

display 

Fault diagnosis:

This is a status code. It indicates that the system has entered refrigerant recycle running state and will automatically start.

Possible causes: --

Troubleshooting: not required.

2.3 "A3" Defrosting State

Fault display: main board of outdoor unit, wired controller of indoor unit and receiver of indoor unit

display 

Fault diagnosis:

This is a status code. It indicates that the system has entered defrosting state. In this case, the indoor fan will stop working for 5 to 10 minutes.

Possible causes: --

Troubleshooting: not required.

2.4 "A4" Oil Return State

Fault display: main board of outdoor unit, wired controller of indoor unit and receiver of indoor unit

display 

Fault diagnosis:

This is a status code. It indicates that the system has entered oil return state. In case of oil return in

heating mode, the indoor fan will stop working for 5 to 10 minutes.

Possible causes: --

Troubleshooting: not required.

2.5 "A6" Cooling and Heating Function Settings State

Fault display: main board of outdoor unit displays



Fault diagnosis:

This is a status code. It indicates that the system has entered cooling and heating function settings state. In this case, you can select Cooling and Heating (nA), Cooling Only (nC), Heating Only (nH) or Fan Type (nF).

Possible causes: --

Troubleshooting: not required.

2.6 "A7" Silent Mode Settings State

Fault display: main board of outdoor unit displays



Fault diagnosis:

This is a status code. It indicates that the system has entered silent mode settings state.

Possible causes: --

Troubleshooting: not required.

2.7 "A8" Vacuum Pumping Mode

Fault display: main board of outdoor unit displays



Fault diagnosis:

This is a status code. It indicates that the system has entered vacuum pumping mode and relevant expansion valves and solenoid valves will open.

Possible causes: --

Troubleshooting: not required.

2.8 "AH" Heating State

Fault display: main board of outdoor unit displays



Fault diagnosis:

This is a status code. It indicates that the system has entered heating mode.

Possible causes: --

Troubleshooting: not required.

2.9 "AC" Cooling State

Fault display: main board of outdoor unit displays



Fault diagnosis:

This is a status code. It indicates that the system has entered cooling mode.

Possible causes: --

Troubleshooting: not required.

2.10 "AF" Fan State

Fault display: main board of outdoor unit displays



Fault diagnosis:

This is a status code. It indicates that the system has entered the fan mode. In this case, all the indoor units operate only in fan mode.

Possible causes: --

Troubleshooting: not required.

2.11 "AE" Artificial Refrigerant Charging State

Fault display: main board of outdoor unit displays



Fault diagnosis:

This is a status code. It indicates that the system has employed artificial refrigerant charging mode.

Possible causes: --

Troubleshooting: not required.

2.12 "AJ" Filter Clean Prompt

Fault display: wired controller of indoor unit and receiver of indoor unit display



Applicable models: all indoor units

Fault diagnosis:

This is a status code. It indicates that the filter of indoor unit needs to be cleaned. The cleaning interval of filter can be set according to actual circumstances.

Possible causes: --

Troubleshooting: Clean the filter and remove the prompt to have the filter proceeds to the next service cycle.

2.13 "AP" Unit Commissioning Startup Confirmation

Fault display: main board of outdoor unit displays



Fault diagnosis:

This is a status code. It indicates that the unit has been commissioned and is ready for operation.

Possible causes: --

Troubleshooting: not required.

2.14 "AU" Remote Control for Emergency Stop

Fault display: main board of outdoor unit, wired controller of indoor unit and receiver of indoor unit

display 

Fault diagnosis:

This is a status code. It indicates that the unit is in emergency stop status through remote centralized control, and it cannot be started unless such state is disabled.

Possible causes: --

Troubleshooting: not required.

2.15 "Ab" Emergency Stop

Fault display: main board of outdoor unit, wired controller of indoor unit and receiver of indoor unit

display 

Fault diagnosis:

This is a status code. It indicates that the main board of outdoor unit has received emergency stop signal, and the unit cannot be started unless such state is disabled.

Possible causes: --

Troubleshooting: not required.

2.16 "Ad" Restricted Running State

Fault display: main board of outdoor unit, wired controller of indoor unit and receiver of indoor unit

display 

Fault diagnosis:

This is a status code. It indicates that an emergency running state has been set for the system, but the unit is not allowed to perform emergency running because the emergency running has reached the time limit.

Possible causes: --

Troubleshooting: not required.

2.17 "b1" Outdoor Ambient Temperature Sensor Fault

Fault display: main board of outdoor unit, wired controller of indoor unit and receiver of indoor unit

display 

Fault diagnosis:

The temperature sensor detection circuit samples the AD value of temperature sensor and determines the range of AD value. When the sampled AD value exceeds the limits for 30 consecutive seconds, the fault is generated.

Possible causes:

- Poor contact between the temperature sensor and the main board interface;
- Abnormal temperature sensor;
- Abnormal detection circuit.

Troubleshooting:

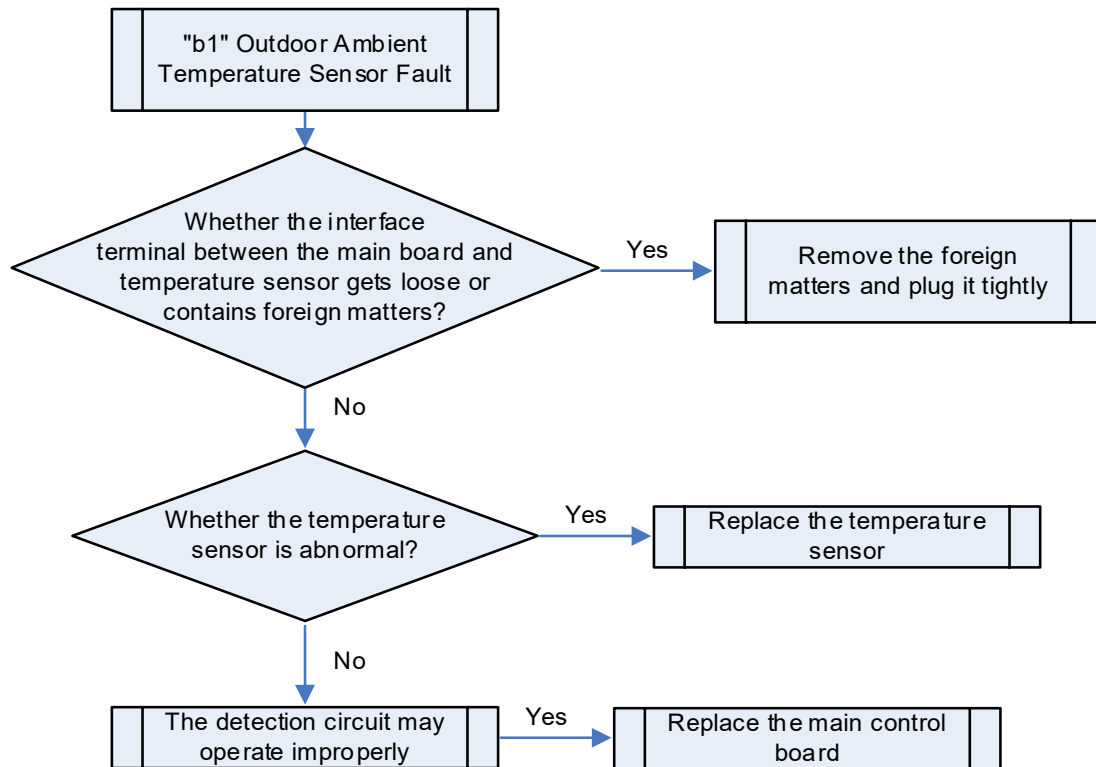

2.18 "b2" Defrosting Temperature Sensor 1 Fault

Fault display: main board of outdoor unit, wired controller of indoor unit and receiver of indoor unit

display 

Fault diagnosis:

The temperature sensor detection circuit samples the AD value of temperature sensor and determines the range of AD value. When the sampled AD value exceeds the limits for 30 consecutive seconds, the fault is generated.

Possible causes:

- Poor contact between the temperature sensor and the main board interface;
- Abnormal temperature sensor;
- Abnormal detection circuit.

Troubleshooting:

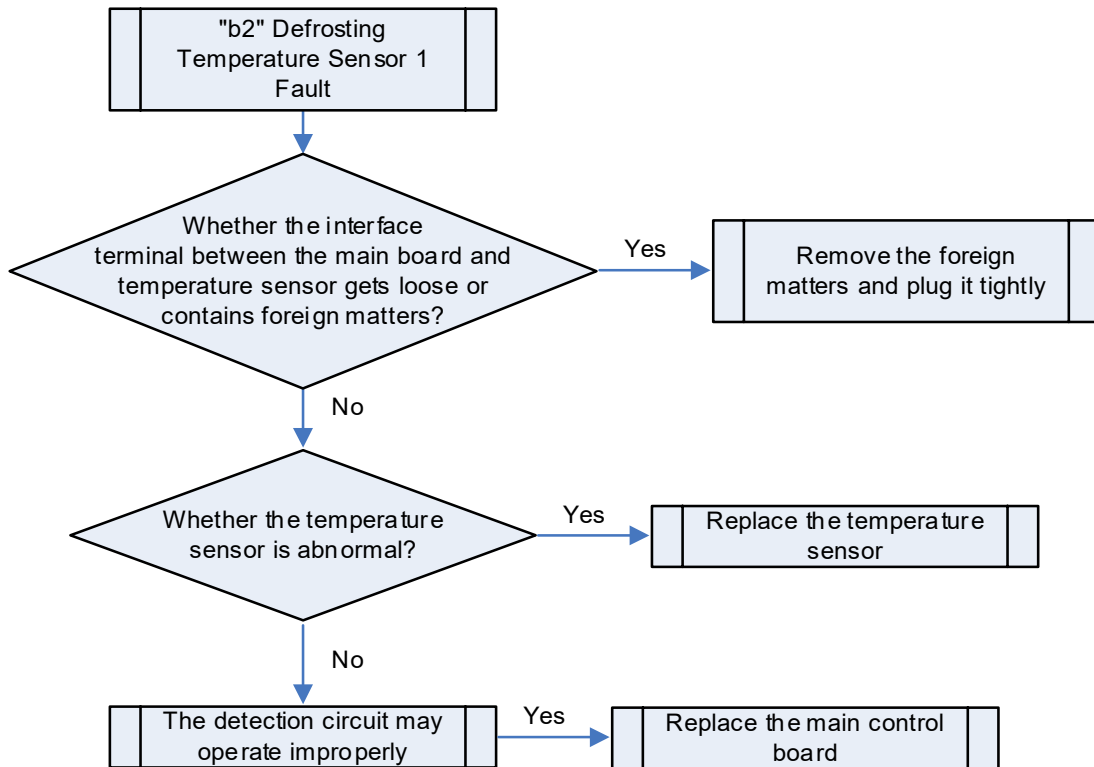

2.19 "b3" Defrosting Temperature Sensor 2 Fault

Fault display: main board of outdoor unit, wired controller of indoor unit and receiver of indoor unit

display 

Fault diagnosis:

The temperature sensor detection circuit samples the AD value of temperature sensor and determines the range of AD value. When the sampled AD value exceeds the limits for 30 consecutive seconds, the fault is generated.

Possible causes:

- Poor contact between the temperature sensor and the main board interface;
- Abnormal temperature sensor;
- Abnormal detection circuit.

Troubleshooting:

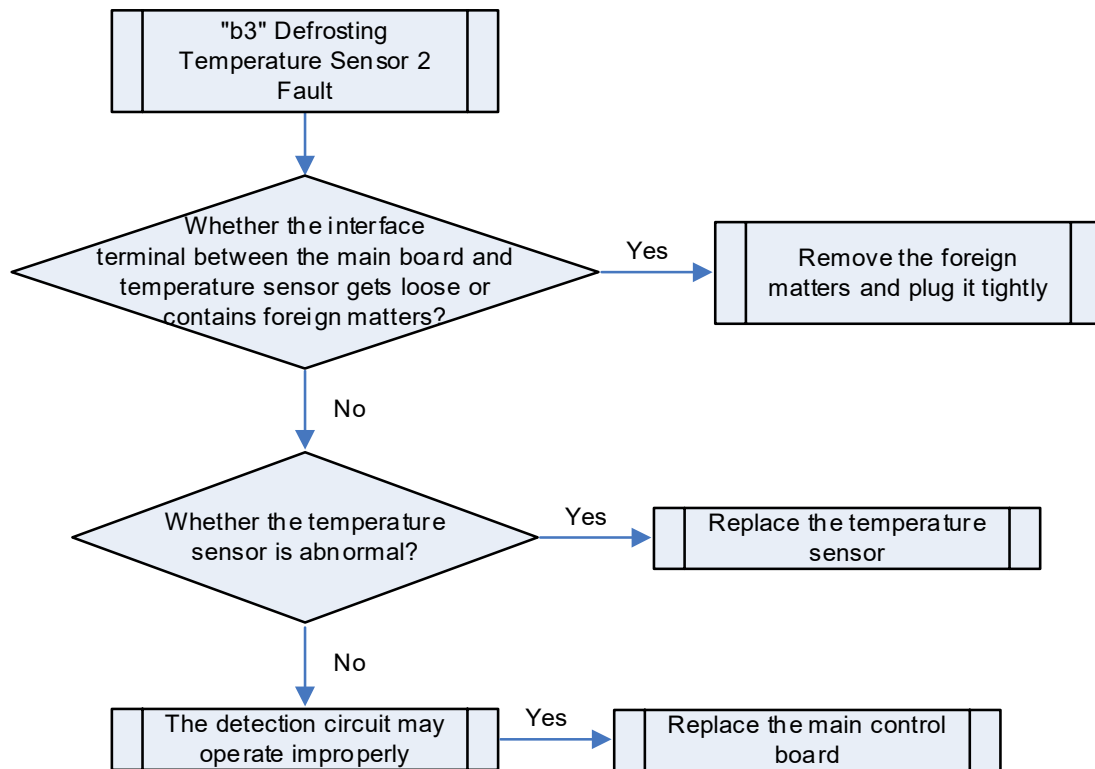

2.20 "b4" Subcooler's Liquid Outlet Temperature Sensor Fault

Fault display: main board of outdoor unit, wired controller of indoor unit and receiver of indoor unit

display 

Fault diagnosis:

The temperature sensor detection circuit samples the AD value of temperature sensor and determines the range of AD value. When the sampled AD value exceeds the limits for 30 consecutive seconds, the fault is generated.

Possible causes:

- Poor contact between the temperature sensor and the main board interface;
- Abnormal temperature sensor;
- Abnormal detection circuit.

Troubleshooting:

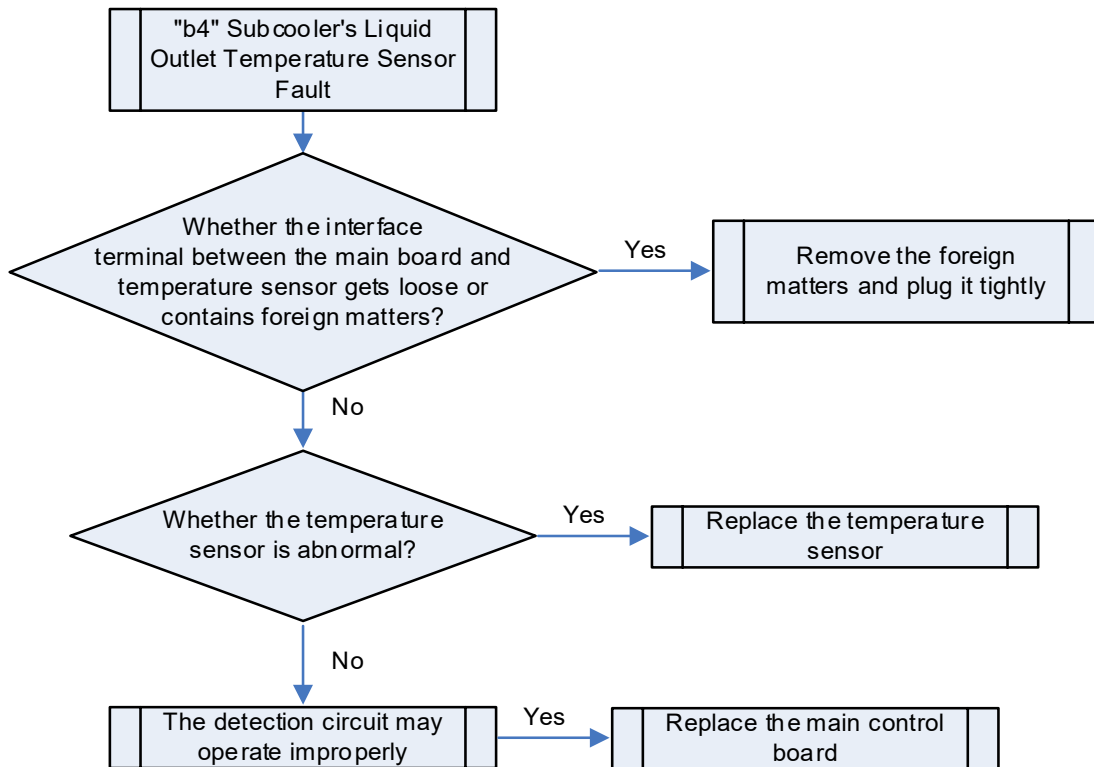

2.21 "b5" Subcooler's Gas Outlet Temperature Sensor Fault

Fault display: main board of outdoor unit, wired controller of indoor unit and receiver of indoor unit

display 

Fault diagnosis:

The temperature sensor detection circuit samples the AD value of temperature sensor and determines the range of AD value. When the sampled AD value exceeds the limits for 30 consecutive seconds, the fault is generated.

Possible causes:

- Poor contact between the temperature sensor and the main board interface;
- Abnormal temperature sensor;
- Abnormal detection circuit.

Troubleshooting:

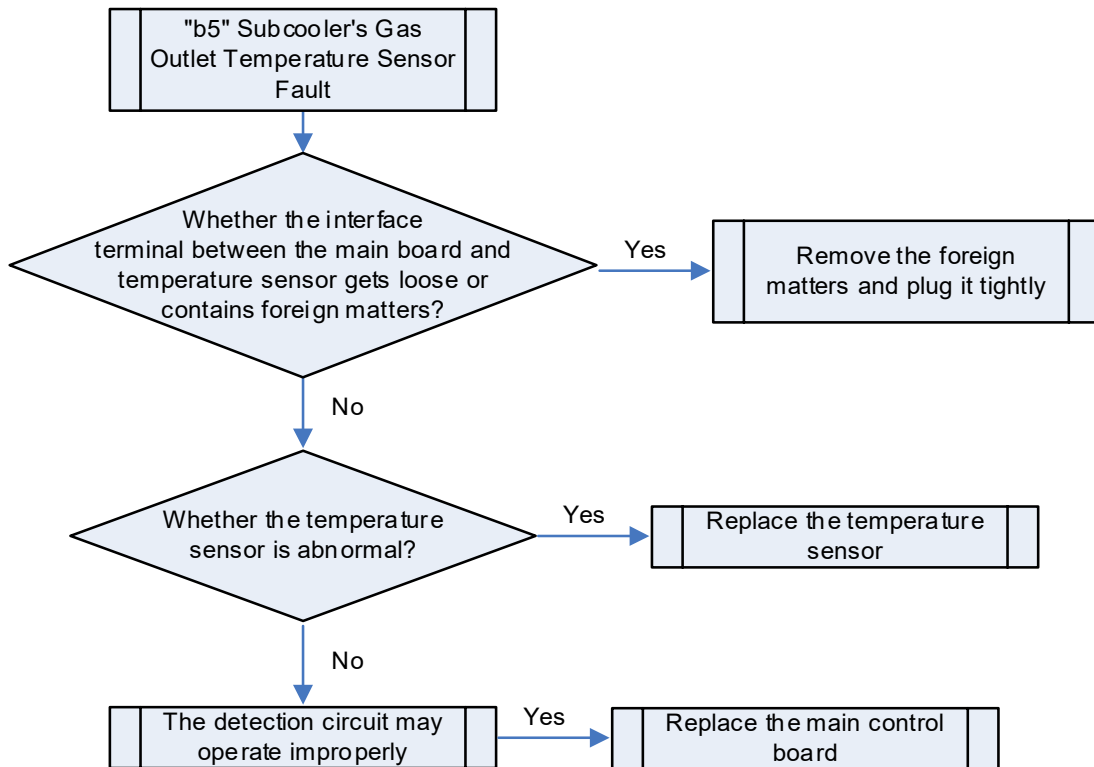

2.22 "b6" Suction Temperature Sensor 1 Fault

Fault display: main board of outdoor unit, wired controller of indoor unit and receiver of indoor unit

display 

Fault diagnosis:

The temperature sensor detection circuit samples the AD value of temperature sensor and determines the range of AD value. When the sampled AD value exceeds the limits for 30 consecutive seconds, the fault is generated.

Possible causes:

- Poor contact between the temperature sensor and the main board interface;
- Abnormal temperature sensor;
- Abnormal detection circuit.

Troubleshooting:

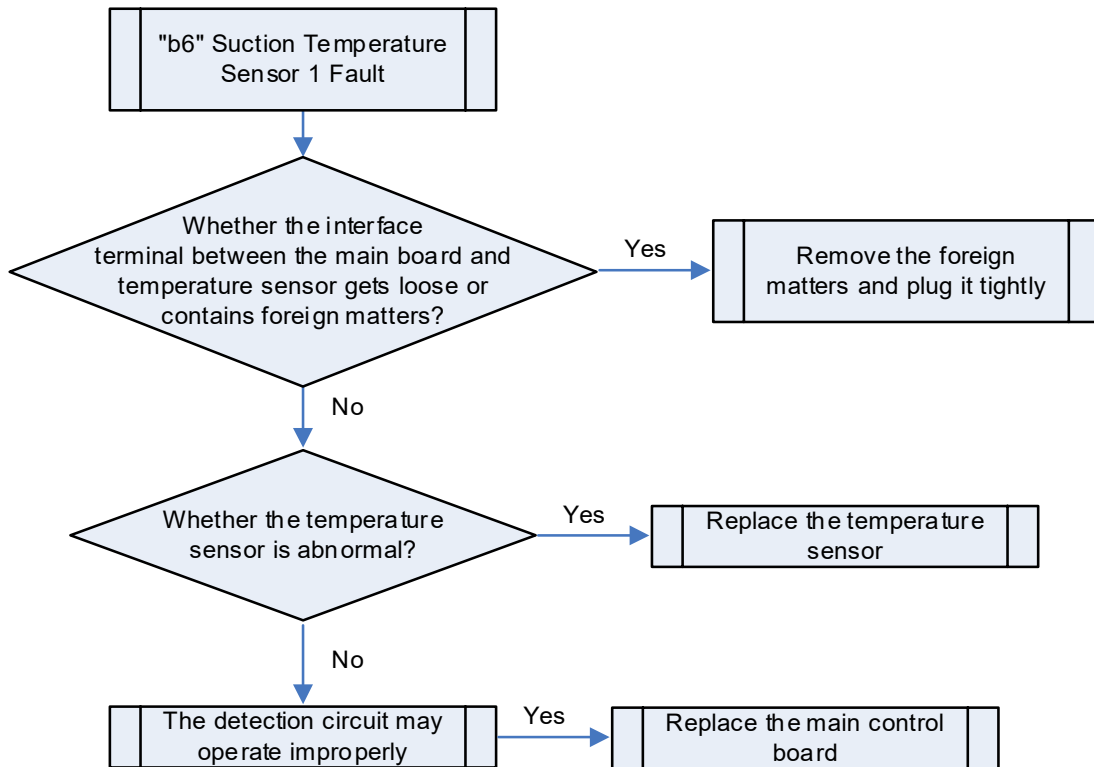

2.23 "b7" Suction Temperature Sensor 2 Fault

Fault display: main board of outdoor unit, wired controller of indoor unit and receiver of indoor unit

display 

Fault diagnosis:

The temperature sensor detection circuit samples the AD value of temperature sensor and determines the range of AD value. When the sampled AD value exceeds the limits for 30 consecutive seconds, the fault is generated.

Possible causes:

- Poor contact between the temperature sensor and the main board interface;
- Abnormal temperature sensor;
- Abnormal detection circuit.

Troubleshooting:

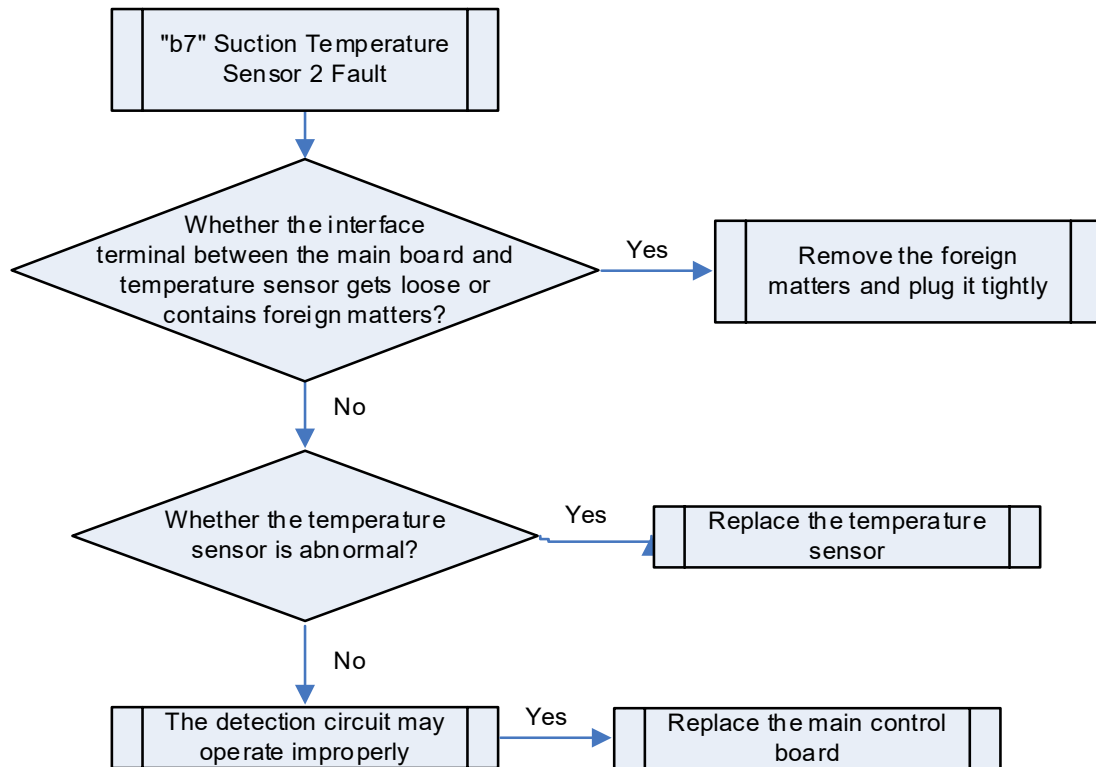

2.24 "b8" Outdoor Humidity Sensor Fault

Fault display: main board of outdoor unit, wired controller of indoor unit and receiver of indoor unit

display 

Fault diagnosis:

The temperature sensor detection circuit samples the AD value of temperature sensor and determines the range of AD value. When the sampled AD value exceeds the limits for 30 consecutive seconds, the fault is generated.

Possible causes:

- Poor contact between the temperature sensor and the main board interface;
- Abnormal temperature sensor;
- Abnormal detection circuit.

Troubleshooting:

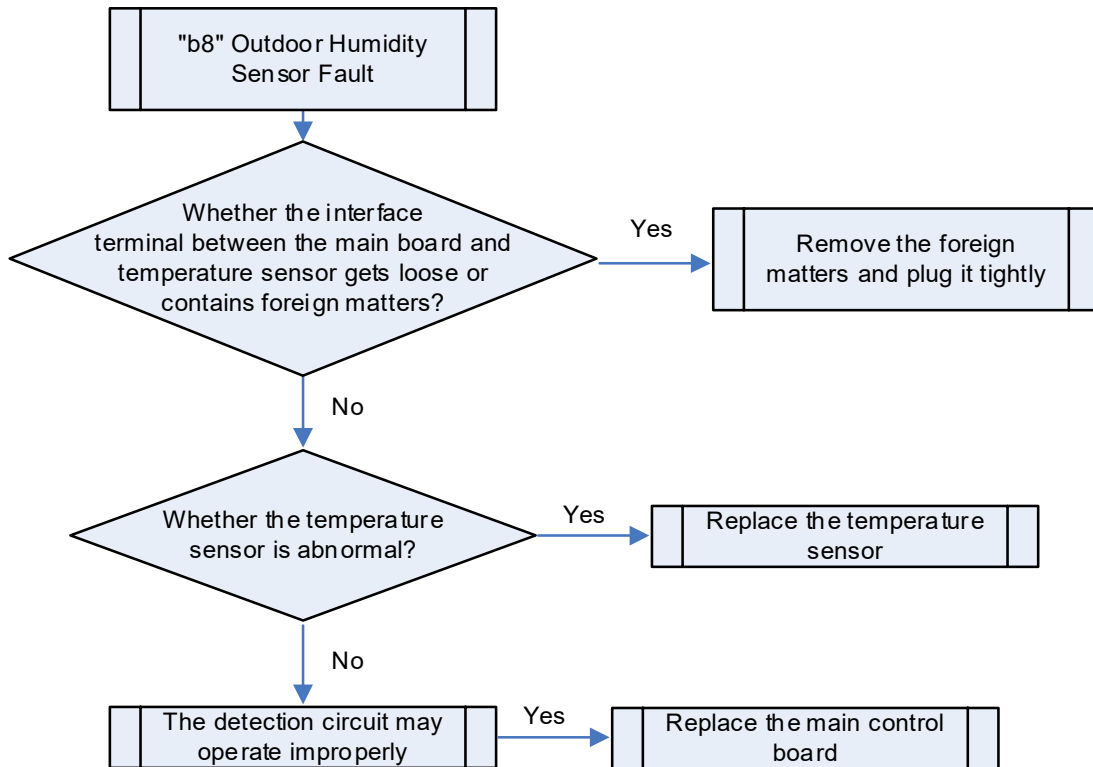

2.25 "b9" Heat Exchanger's Gas Outlet Temperature Sensor Fault

Fault display: main board of outdoor unit, wired controller of indoor unit and receiver of indoor unit

display 

Fault diagnosis:

The temperature sensor detection circuit samples the AD value of temperature sensor and determines the range of AD value. When the sampled AD value exceeds the limits for 30 consecutive seconds, the fault is generated.

Possible causes:

- Poor contact between the temperature sensor and the main board interface;
- Abnormal temperature sensor;
- Abnormal detection circuit.

Troubleshooting:

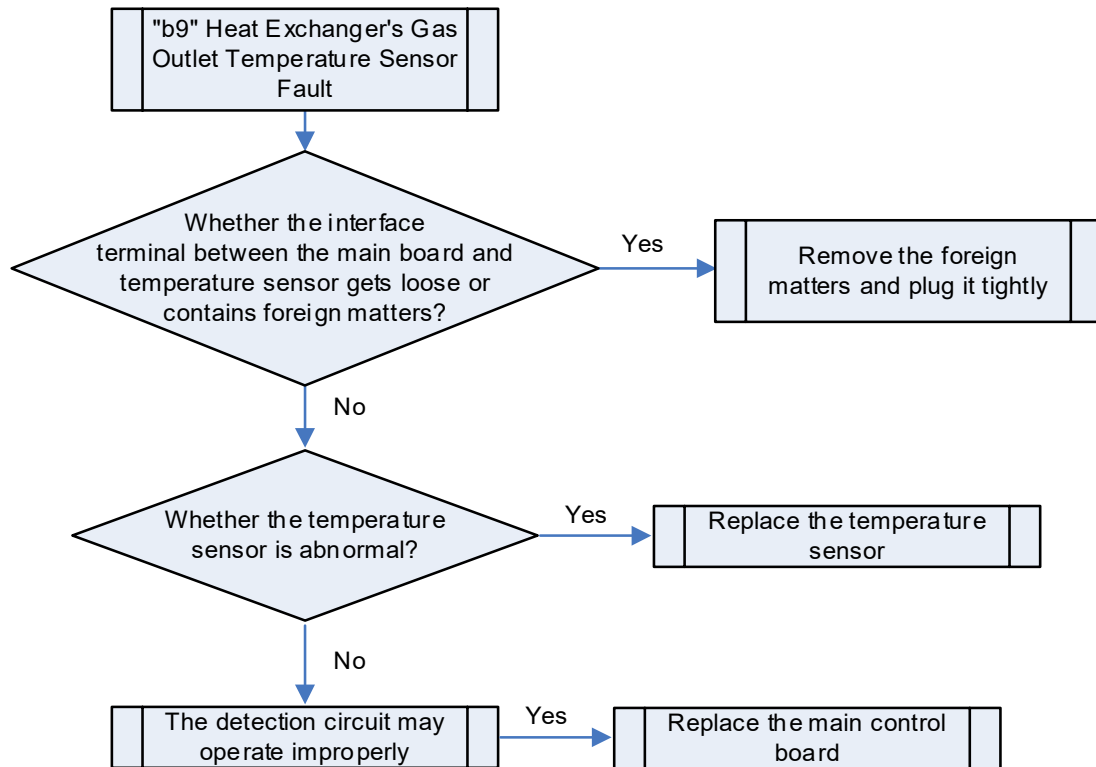

2.26 "bA" Oil Return Temperature Sensor Fault

Fault display: main board of outdoor unit, wired controller of indoor unit and receiver of indoor unit

display 

Fault diagnosis:

The temperature sensor detection circuit samples the AD value of temperature sensor and determines the range of AD value. When the sampled AD value exceeds the limits for 30 consecutive seconds, the fault is generated.

Possible causes:

- Poor contact between the temperature sensor and the main board interface;
- Abnormal temperature sensor;
- Abnormal detection circuit.

Troubleshooting:

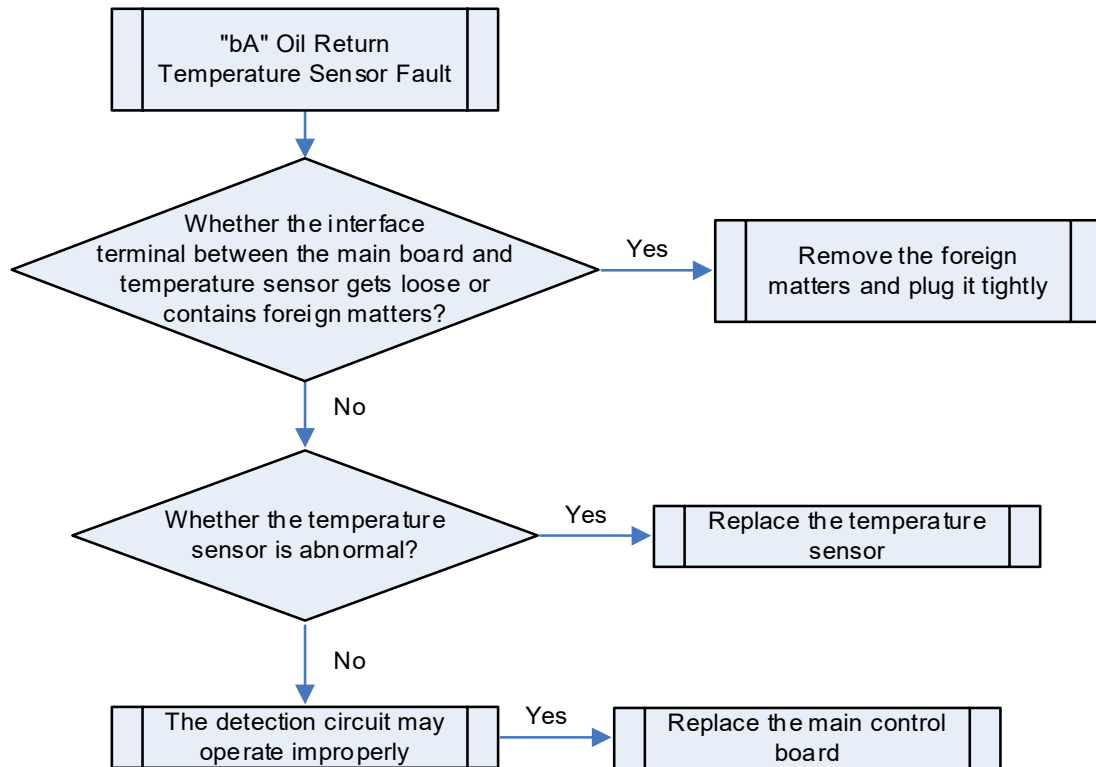

2.27 "bd" Subcooler Air Inlet Temperature Sensor Error

Error display: ODU main board, IDU wired controller, IDU receive light board will display



Applicable model: all ODUs

Error judgment condition and method:

Sample the AD value of temperature sensor through temperature sensor detecting circuit and judge the range of AD value. If the sampling AD value exceeds upper limit and lower limit in 30 seconds continuously, report the error

Possible reasons:

- Poor contact between temperature sensor and terminal in main board interface
- Temperature sensor is abnormal
- Detecting circuit is abnormal

Troubleshooting:

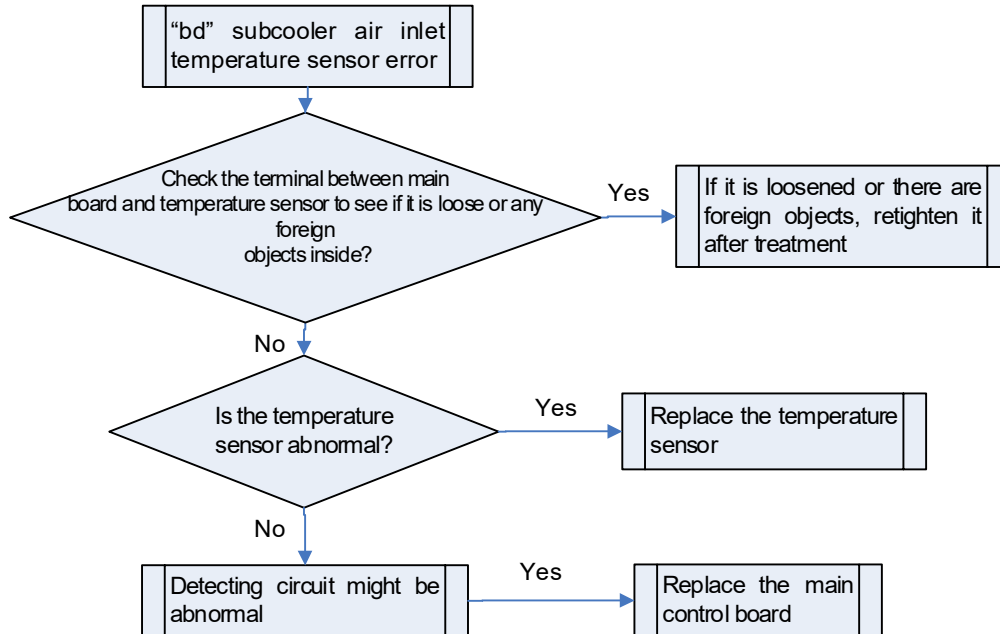

2.28 "bJ" High and Low Pressure Sensor is Wrongly Connected

Error display: ODU main board, IDU wired controller and IDU receive light board will display 

Applicable model: all ODUs

Error judgment condition and method:

Under shutdown status, the high and low pressure sensor has detected that the high pressure test value of module is 30℃ higher than the low pressure, the unit will report that the high and low pressure is wrongly connected.

Possible reasons:

- The resistance of high pressure sensor is abnormal, the test value is high.
- The resistance of low pressure sensor is abnormal, the test value is low.
- High and low pressure sensor is wrongly connected.

Troubleshooting:

Step 1: check if the input voltage of high pressure sensor between "4.9~5.1V" and the output voltage between "0.5~4.5V", if no, replace the high pressure sensor.

Step 2: check if the input voltage of low pressure sensor between "4.9~5.1V" and the output voltage between "0.5~4.5V", if no, replace the high pressure sensor.

Step 3: if the above inspections on input/output voltage of pressure sensor are normal, exchange the corresponding terminal of two pressure sensors.

2.29 "bn" Subcooler Liquid Temperature Sensor Error

Error display: ODU main board, IDU wired controller and IDU receive light board will display 

Applicable model: all ODUs

Error judgment condition and method:

Sample the AD value of temperature sensor through temperature sensor detecting circuit and judge the range of AD value. If the sampling AD value exceeds upper limit and lower limit in 30 seconds continuously, report the error

Possible reasons:

- Poor contact between temperature sensor and terminal in main board interface
- Temperature sensor is abnormal
- Detecting circuit is abnormal

Troubleshooting:

Step 1: check the terminal between main board and temperature sensor to see if it is loose or any foreign objects inside? If yes, reconnect it after treatment;

Step 2: check if the temperature sensor is abnormal, if yes, replace the temperature sensor;

Step 3: if the above inspections are normal, the detecting circuit might be abnormal, please replace the main board.

2.30 "C0" Communication Fault Between Indoor and Outdoor Units and Between Indoor Unit and Wired Controller

Fault display: main board of outdoor unit, wired controller of indoor unit and receiver of indoor unit

display 

Fault diagnosis:

There is no communication between the outdoor unit and indoor unit or between the indoor unit and wired controller for 30 seconds, and a fault is generated.

Possible causes:

- Communication cables are connected wrongly or get loose;
- Communication cables are broken;
- Poor contact of communication cables;
- Number of wired controllers connected or addresses are set improperly;
- Controller operates improperly.

Troubleshooting:

If the main control board of outdoor unit does not display C0, check the connection between the indoor unit and the wired controller; if the main control board of outdoor unit, indoor unit's receiver and wired controller display C0, check the connection between the indoor unit and outdoor unit and between the indoor unit and wired controller; if only the wired controller displays C0, check the connection between the indoor unit and wired controller, the number of wired controllers connected and address settings.

Perform the troubleshooting as follows:

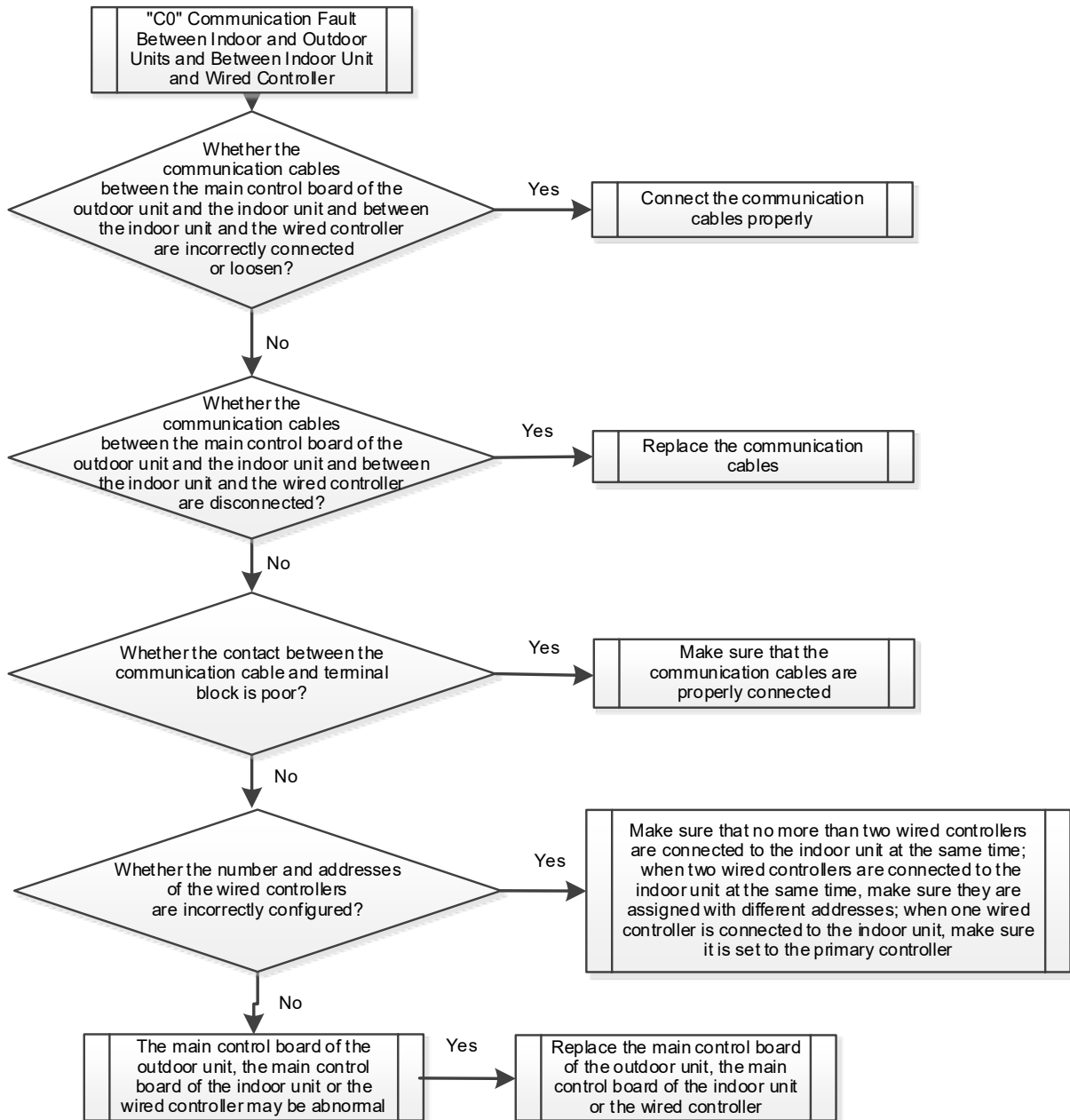

2.31 "C2" Communication Fault Between the Primary Controller and Inverter Compressor Driver

Fault display: main board of outdoor unit, wired controller of indoor unit and receiver of indoor unit

display 

Fault diagnosis:

When the outdoor unit fails to detect inverter compressor driver for 30 consecutive seconds, the fault is generated.

Possible causes:

- The communication cables between the main board of outdoor unit and inverter compressor driver inside the module are connected improperly;
- The inverter compressor driver operates improperly;

- The main board operates improperly.

Troubleshooting:

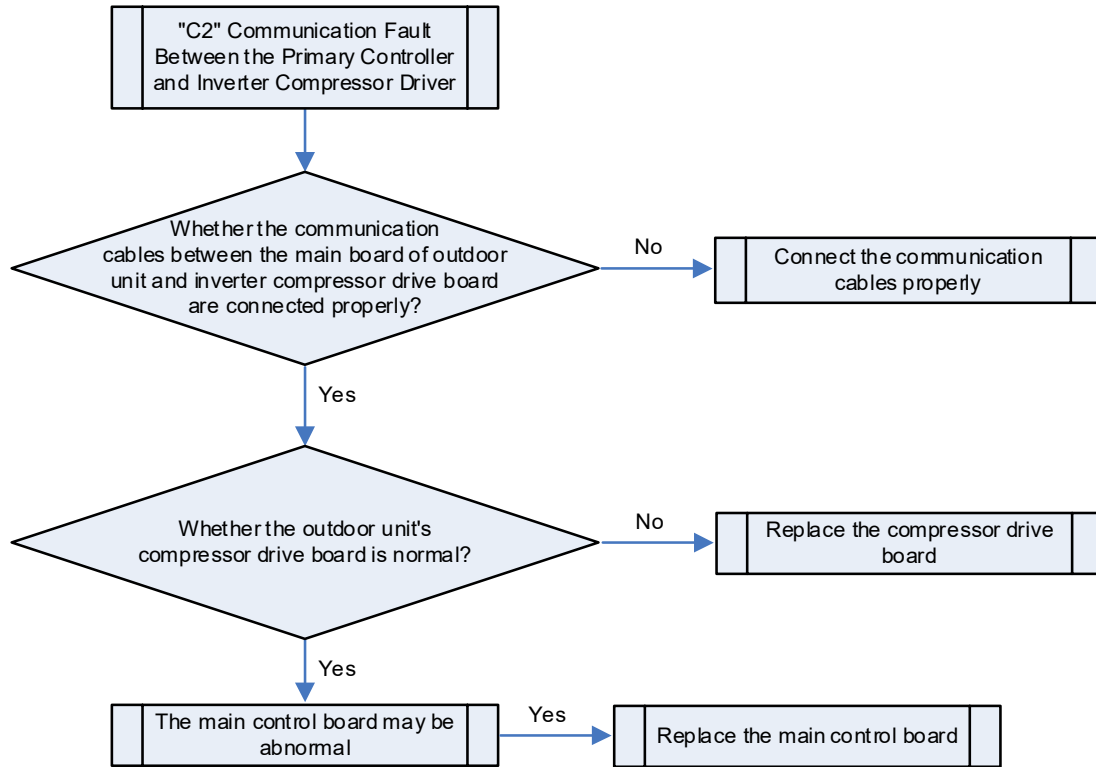

2.32 "C3" Communication Fault Between the Primary Controller and Inverter Fan Driver

Fault display: main board of outdoor unit, wired controller of indoor unit and receiver of indoor unit

display 

Fault diagnosis:

When the outdoor unit fails to detect inverter fan driver for 30 consecutive seconds, the fault is generated.

Possible causes:

- The communication cables between the main board of outdoor unit and inverter fan driver inside the module are connected improperly;
- The inverter fan driver operates improperly;
- The main board operates improperly.

Troubleshooting:

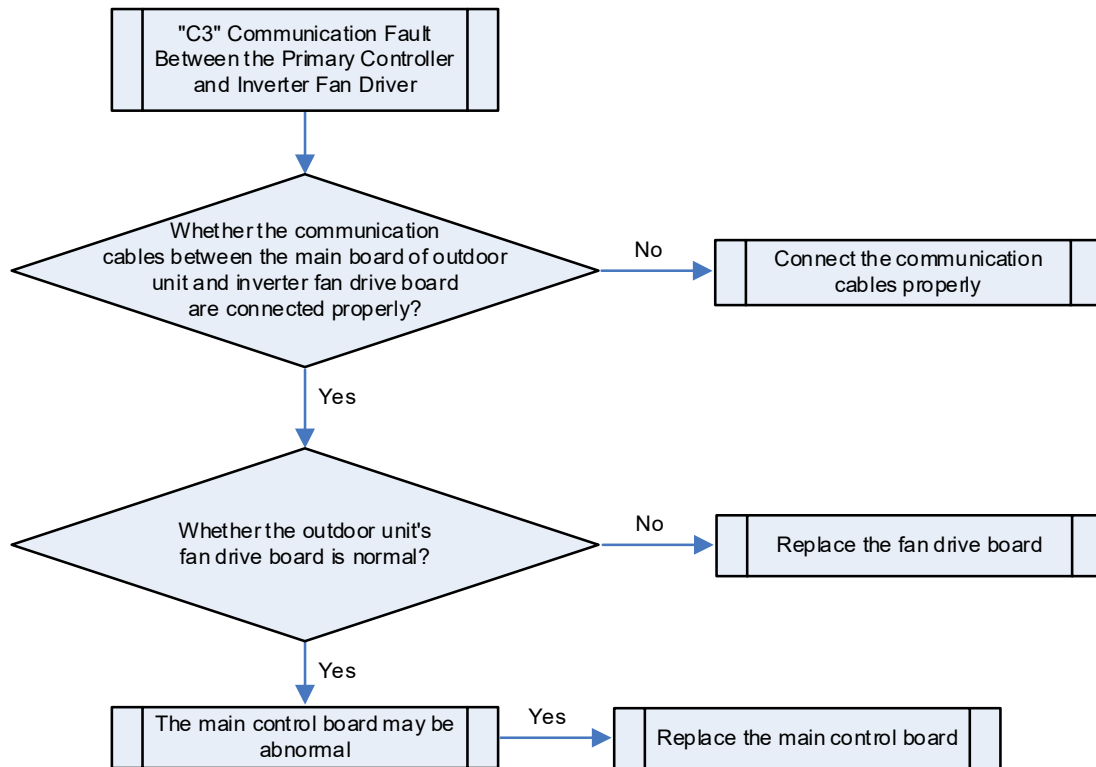

2.33 "C4" Indoor Unit Loss Fault

Fault display: main board of outdoor unit, wired controller of indoor unit and receiver of indoor unit

display 

Fault diagnosis:

When the unit identifies that more than three indoor units are disconnected, it will stop for protection.

Possible causes:

- Poor contact of communication cables;
- The indoor units are powered off;
- The main board of indoor unit operates improperly.

Troubleshooting:

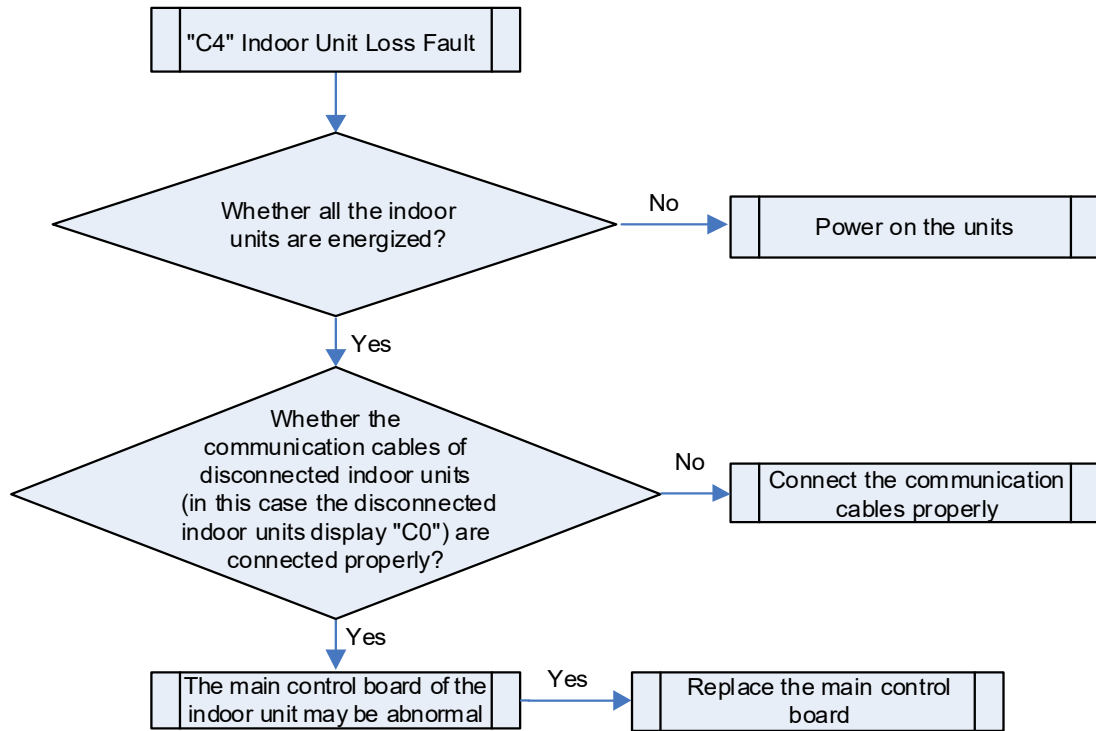

2.34 "C5" Indoor Unit Engineering SN Conflict

Fault display: commissioning software and remote monitoring software display the fault ; The wired controller of indoor unit and receiver of indoor unit do not display the fault.

Fault diagnosis:

Check the engineering SN of indoor units, as the indoor units having the same numbers generate the same fault. However, the fault is displayed and required to be removed only when the commissioning software, centralized controller and remote monitoring are connected.

In the case of non-centralized control, the conflict in terms of the engineering SNs of some indoor units, if any, do not affect the operation of themselves and of the entire system.

Possible causes:

- The same engineering SN is configured for different indoor units;
- The main board of indoor unit is from another unit.

Troubleshooting:

There are several ways to reset the conflicting engineering SN of an indoor unit:

by commissioning software;

by wired controller;

by commissioning the remote controller;

by pressing the Reset button on the main board of indoor unit so that the system reassigns the numbers.

2.35 "C6" Alarm on Inconsistent Number of Outdoor Units

Fault display: main board of outdoor unit, wired controller of indoor unit and receiver of indoor unit

display 

Fault diagnosis:

The unit detects the number of online outdoor modules in real time. When it detects that the number of current modules is inconsistent with the number of modules previously commissioned and memorized, the unit will report the fault and stop working.

Possible causes:

- Abnormal communication among modules;
- The modules are not powered on.

Troubleshooting:

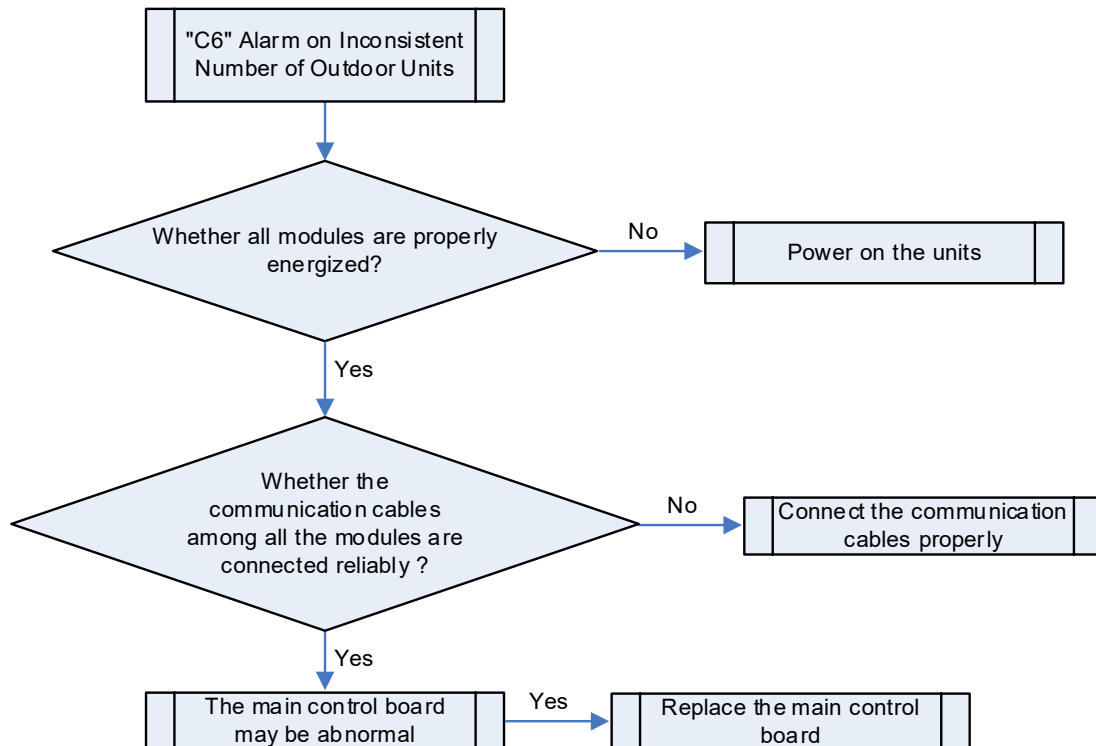

2.36 "C8" Emergency Operation of Compressor

Fault display: main board of outdoor unit displays 

Fault diagnosis:

If any compressor is set to emergency operation mode, the main board displays the code during the operation, indicating that the unit's compressor has entered emergency operation.

Possible causes: --

Troubleshooting: not required.

2.37 "C9" Emergency Operation of Fan

Fault display: main board of outdoor unit displays 

Fault diagnosis:

If any fan is set to emergency operation mode, the main board displays the code during the operation,

indicating that the unit's fan has entered emergency operation.

Possible causes: --

Troubleshooting: not required.

2.38 "CA" Emergency Operation of Module

Fault display: main board of outdoor unit displays



Fault diagnosis:

If any module is set to emergency operation mode, the main board displays the code during the operation, indicating that the unit's module has entered emergency operation.

Possible causes: --

Troubleshooting: not required.

2.39 "CH" Too High Rated Capacity Ratio

Fault display: main board of outdoor unit, wired controller of indoor unit and receiver of indoor unit

display



Fault diagnosis:

The unit detects the rated capacity of the online indoor and outdoor units. When the ratio of the total rated capacity of indoor units to the total rated capacity of outdoor units exceeds 1.35, the unit will stop operation and display the fault.

Possible causes:

■ The total rated capacity of the indoor units exceeds 1.35 times of the total rated capacity of the outdoor units.

Troubleshooting:

Re-engineer the unit to decrease indoor unit capacity or increase outdoor unit capacity.

2.40 "CL" Too Low Rated Capacity Ratio

Fault display: main board of outdoor unit, wired controller of indoor unit and receiver of indoor unit

display



Fault diagnosis:

The unit detects the rated capacity of the online indoor and outdoor units. When the ratio of the total rated capacity of indoor units to the total rated capacity of outdoor units is below 0.5, the unit will stop operation and display the fault.

Possible causes:

■ The total rated capacity of the indoor units is smaller than 0.5 times of the total rated capacity of the outdoor units.

Troubleshooting:

Re-engineer the unit to increase indoor unit capacity or decrease outdoor unit capacity.

2.41 "CJ" System Address Code Conflict

Fault display: main board of outdoor unit, wired controller of indoor unit and receiver of indoor unit



Fault diagnosis:

When multiple refrigerant systems are connected through the CAN2 network of the unit's main board, only one primary system is allowed in the network.

If two or more master units' DIP switches (SA2) are detected to be master unit's DIP switches in the network (that is, SA2 DIP switch is "00000"), the fault of multiple master units is reported.

Possible causes:

- If two or more master units' DIP switches (SA2) are detected to be master unit's DIP switches, keep only one master unit's DIP switch (SA2) to be "00000" and other master units' DIP switches (SA2) to be different;
- Abnormal DIP switch or main board.

Troubleshooting:

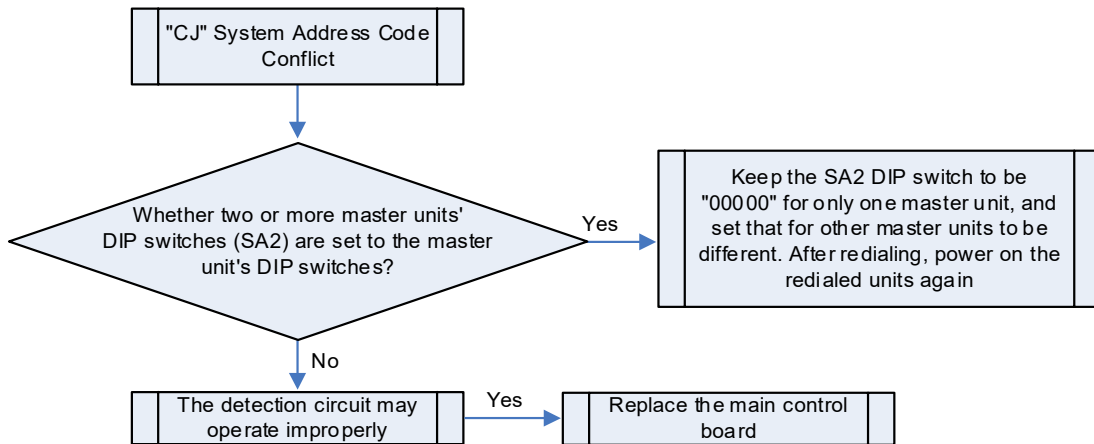

2.42 "CP" Fault of Multiple Main Wired Controllers

Fault display: main board of outdoor unit, wired controller of indoor unit and receiver of indoor unit

display 

Fault diagnosis:

Two or more wired controllers in an HBS network are main wired controllers.

Possible causes:

■ When two (or more) wired controllers control one or more indoor units at the same time, the two (or more) wired controllers are the main wired controllers.

Troubleshooting:

Make sure that at most two wired controllers control one or more indoor units; when two wired controllers control one or more indoor units, enter the wired controller parameter settings (P13) to set the address of one of the wired controllers to be 02 (that is, to be the secondary wired controller).

2.43 "Cb" IP Address Assignment Overflow

Fault display: main board of outdoor unit, wired controller of indoor unit and receiver of indoor unit

display 

Fault diagnosis:

If more than four addresses are assigned to other outdoor units by the outdoor unit, the unit reports an IP address assignment overflow.

If more than 80 (100) addresses are assigned to indoor units by the outdoor unit, the unit reports an IP address assignment overflow.

Possible causes:

■ More than four outdoor units exist;
■ More than 80 (100) indoor units exist.
■ After replacing the main boards of the indoor units and the outdoor units, the outdoor units are not powered off.

Troubleshooting:

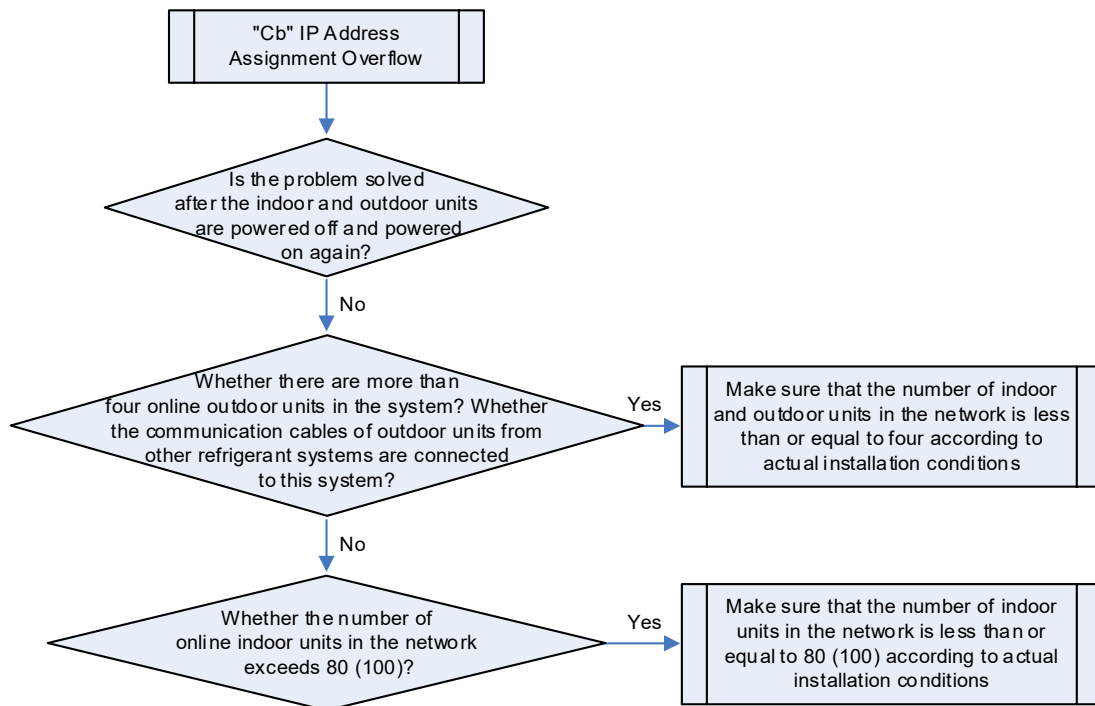

Note: When the number of indoor units is 100, engineering customization is required.

2.44 "d1" Poor Indoor Circuit Board

Fault display: wired controller of indoor unit and receiver of indoor unit display



Fault diagnosis:

Check whether the address chip and memory chip of the indoor unit's main board can be read properly. If not, the fault is generated.

Possible causes:

- Abnormal address chip;
- Abnormal memory chip.

Troubleshooting:

Replace the main control board.

2.45 "d2" Water Tank Temperature Sensor Error

Error display: wired controller of hydro box displays



Applicable model: hydro box

Error judgment condition and method:

Sample the AD value of temperature sensor through temperature sensor detecting circuit and judge the range of AD value. If the sampling AD value exceeds upper limit and lower limit in 5 seconds continuously, report the error

Possible reasons:

- Poor contact between water tank temperature sensor and terminal in main board interface
- Water tank temperature sensor is abnormal
- Detecting circuit is abnormal

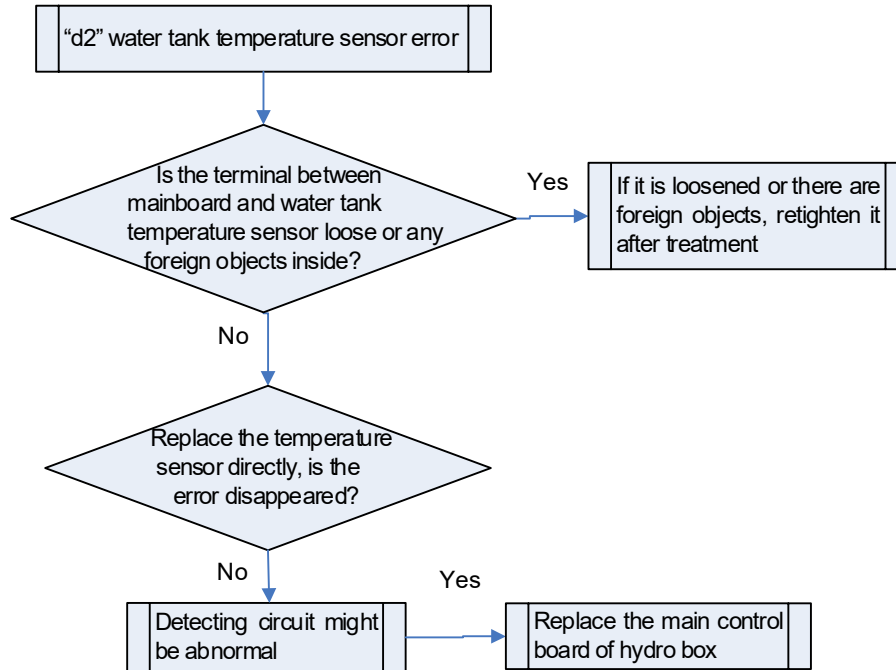
Troubleshooting:

2.46 "d3" Ambient Temperature Sensor Fault

Fault display: wired controller of indoor unit and receiver of indoor unit display

**Fault diagnosis:**

The temperature sensor detection circuit samples the AD value of temperature sensor and determines the range of AD value. When the sampled AD value exceeds the limits for 5 consecutive seconds, the fault is generated.

Possible causes:

- Poor contact between the ambient temperature sensor and the main board interface;
- Abnormal ambient temperature sensor;
- Abnormal detection circuit.

Troubleshooting:

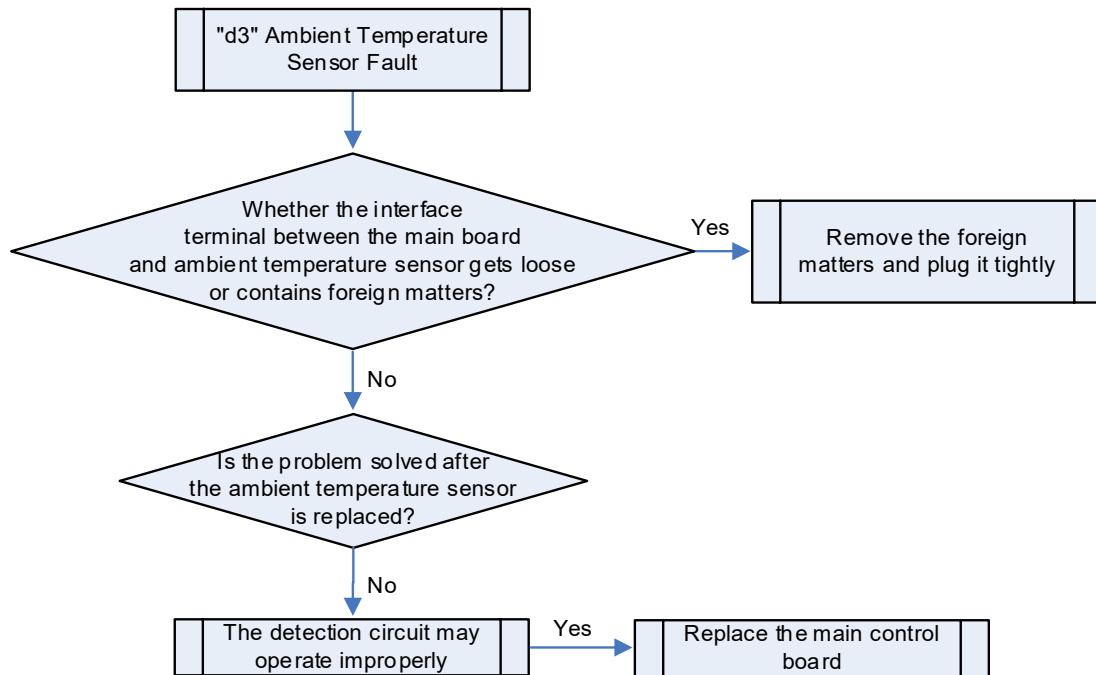

2.47 "d4" Inlet Pipe Temperature Sensor Fault



Fault display: wired controller of indoor unit and receiver of indoor unit display

Fault diagnosis:

The temperature sensor detection circuit samples the AD value of temperature sensor and determines the range of AD value.

When the sampled AD value exceeds the limits for 5 consecutive seconds, the fault is generated.

Possible causes:

- Poor contact between the inlet pipe temperature sensor and the main board interface;
- Abnormal inlet pipe temperature sensor;
- Abnormal detection circuit.

Troubleshooting:

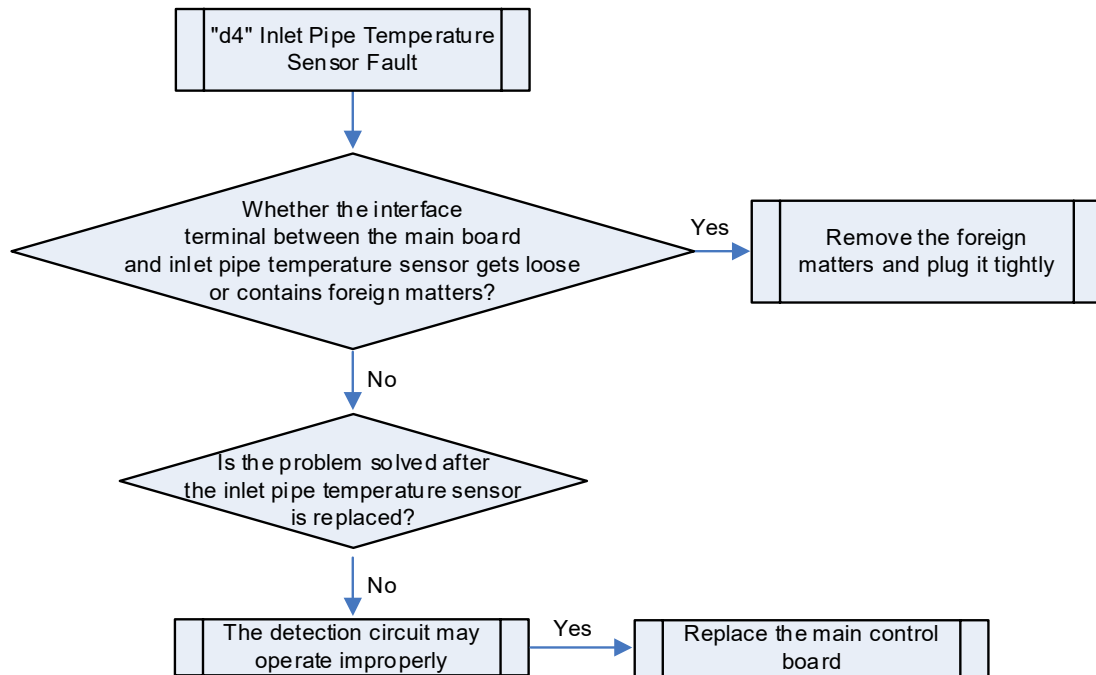

2.48 "d5" Middle Part Temperature Sensor Fault (Reserved)

2.49 "d6" Outlet Pipe Temperature Sensor Fault

Fault display: wired controller of indoor unit and receiver of indoor unit display



Fault diagnosis:

The temperature sensor detection circuit samples the AD value of temperature sensor and determines the range of AD value. When the sampled AD value exceeds the limits for 5 consecutive seconds, the fault is generated.

Possible causes:

- Poor contact between the outlet pipe temperature sensor and the main board interface;
- Abnormal outlet pipe temperature sensor;
- Abnormal detection circuit.

Troubleshooting:

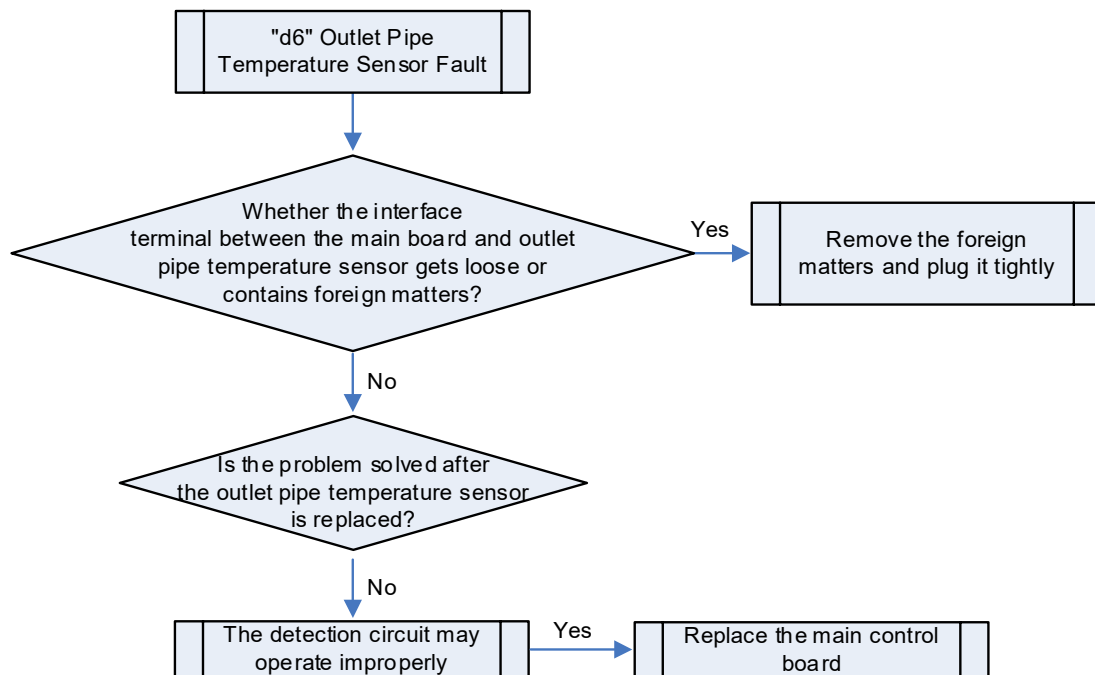

2.50 "d7" Humidity Sensor Fault

Fault display: wired controller of indoor unit and receiver of indoor unit display



Fault diagnosis:

The temperature sensor detection circuit samples the AD value of temperature sensor and determines the range of AD value. When the sampled AD value exceeds the limits for 5 consecutive seconds, the fault is generated.

Possible causes:

- Poor contact between the humidity sensor and the main board interface;
- Abnormal humidity sensor;
- Abnormal detection circuit.

Troubleshooting:

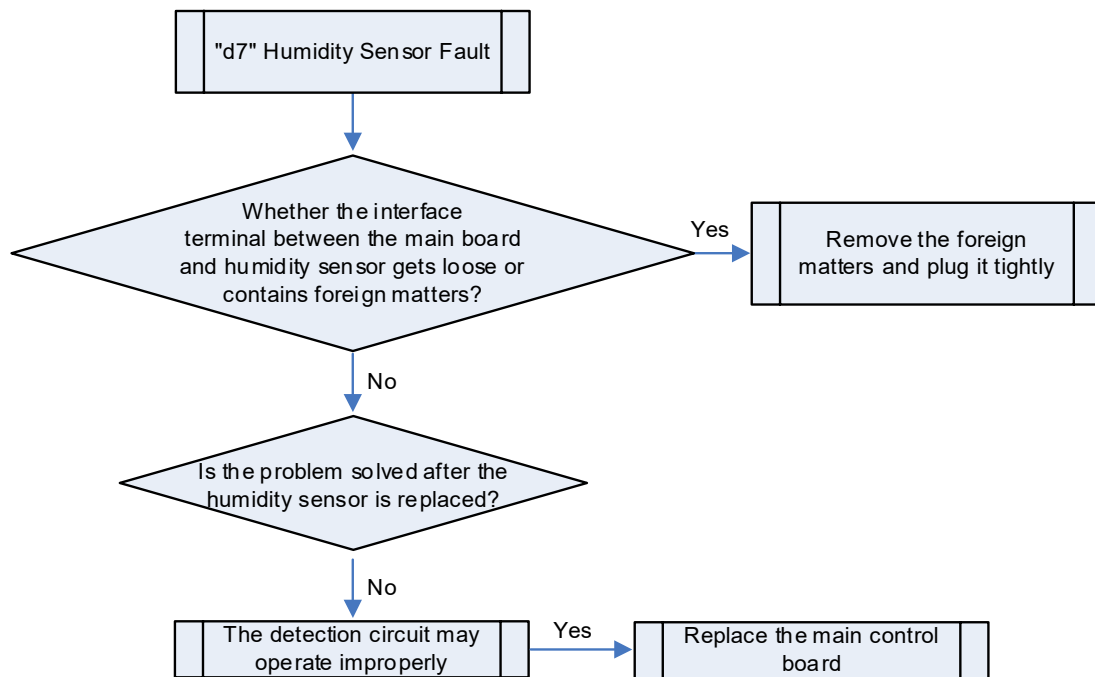

2.51 "d8" Water Temperature Sensor Fault (Reserved)

2.52 "d9" Jumper Cap Fault

Fault display: wired controller of indoor unit and receiver of indoor unit display



Fault diagnosis:

A fault is reported if the jumper cap does not match the main board.

Possible causes:

- The jumper cap is not installed;
- The jumper cap is numbered incorrectly;
- Abnormal detection circuit.

Troubleshooting:

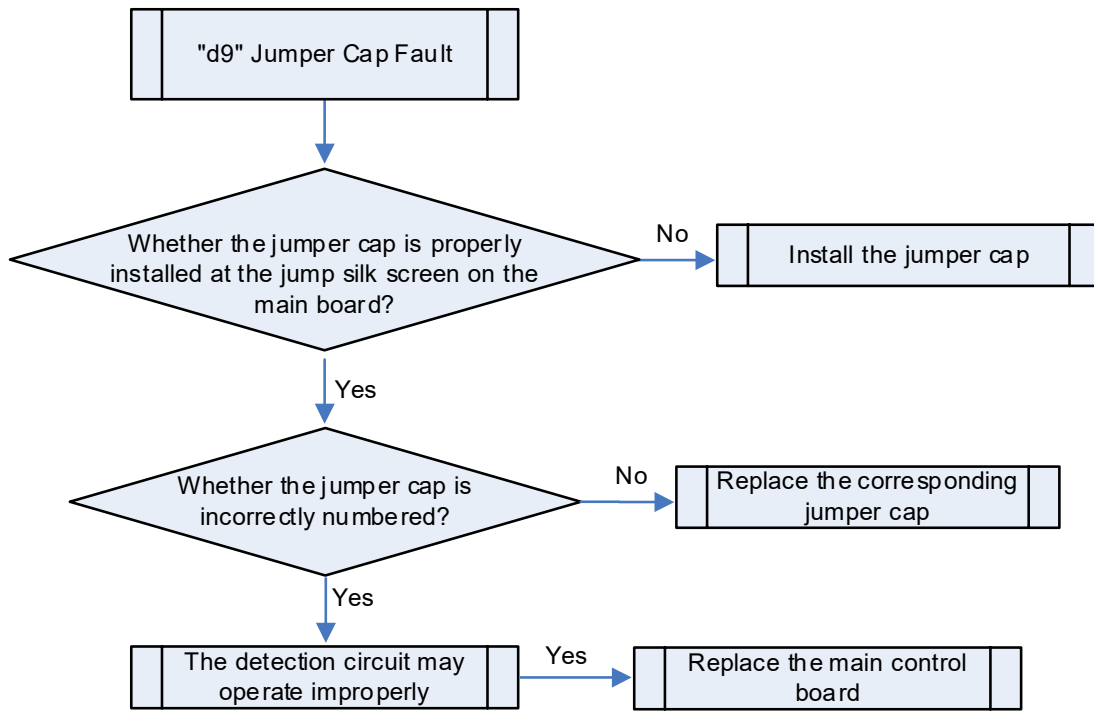

2.53 "dA" Abnormal Network Address of Indoor Unit



Fault display: wired controller of indoor unit and receiver of indoor unit display

Fault diagnosis:

Check the indoor unit's address chip and IP address. If the address chip cannot be read, the indoor unit's IP address is 0 and IP addresses conflict, the fault is generated.

Possible causes:

- Outdoor units' address are assigned incorrectly;
- Indoor unit's processing error;
- Abnormal address chip.

Troubleshooting:

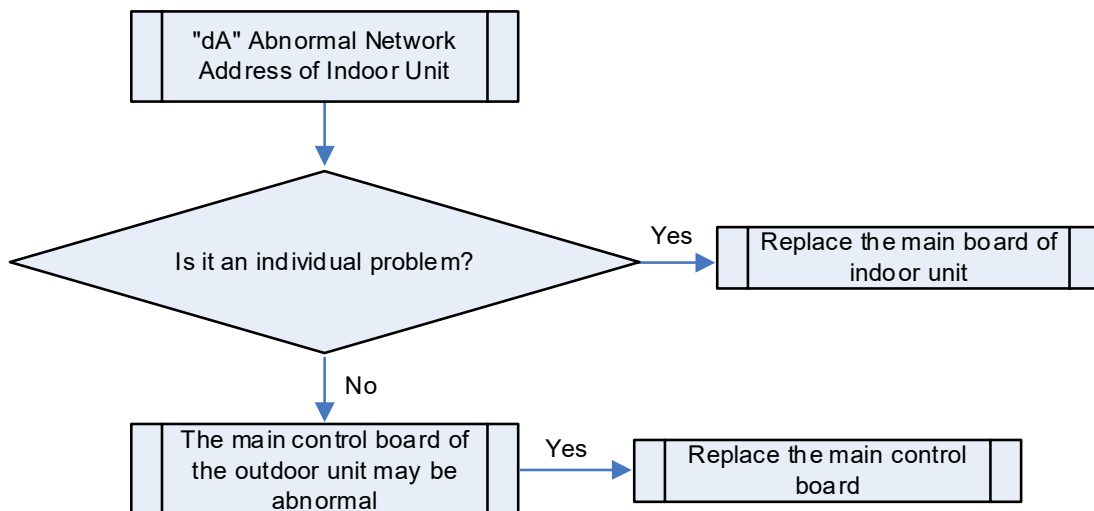

2.54 "dH" Abnormal Circuit Board of Wired Controller



Fault display: wired controller of indoor unit and receiver of indoor unit display

Fault diagnosis:

The wired controller's IIC communication is abnormal.

Possible causes:

- The communication between the wired controller's touch keypad and display panel IIC is abnormal;
- The wired controller's memory chip IIC cannot be read or written properly (if there are any memory chips).

Troubleshooting:

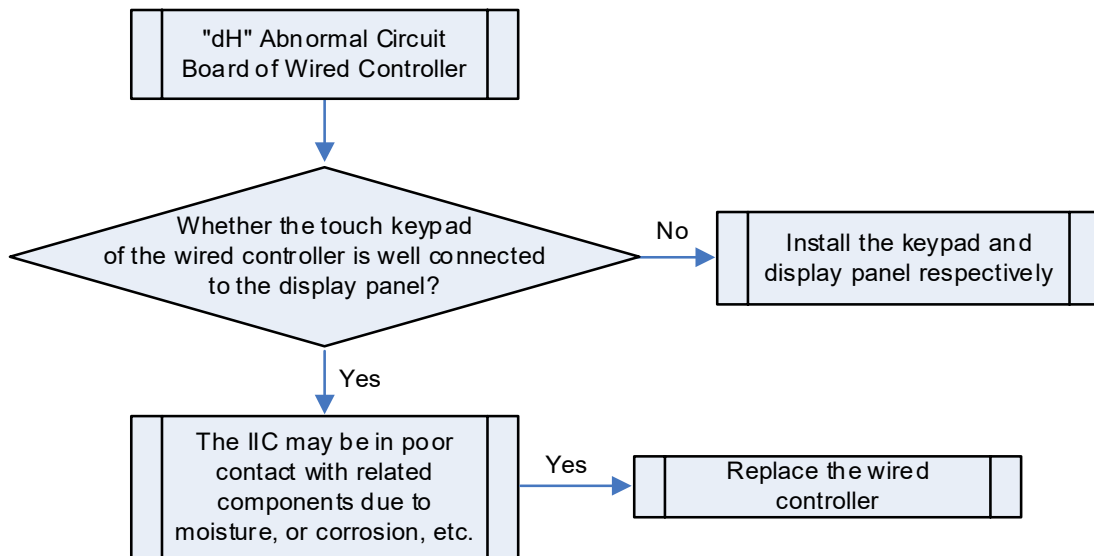

2.55 "dC" Abnormal Settings of DIP Switch for Capacity



Fault display: wired controller of indoor unit and receiver of indoor unit display

Fault diagnosis:

If DIP switch for capacity is set to the wrong position, the fault is generated.

Possible causes:

- DIP switch for capacity is set to a wrong position;
- Abnormal detection circuit.

Troubleshooting:

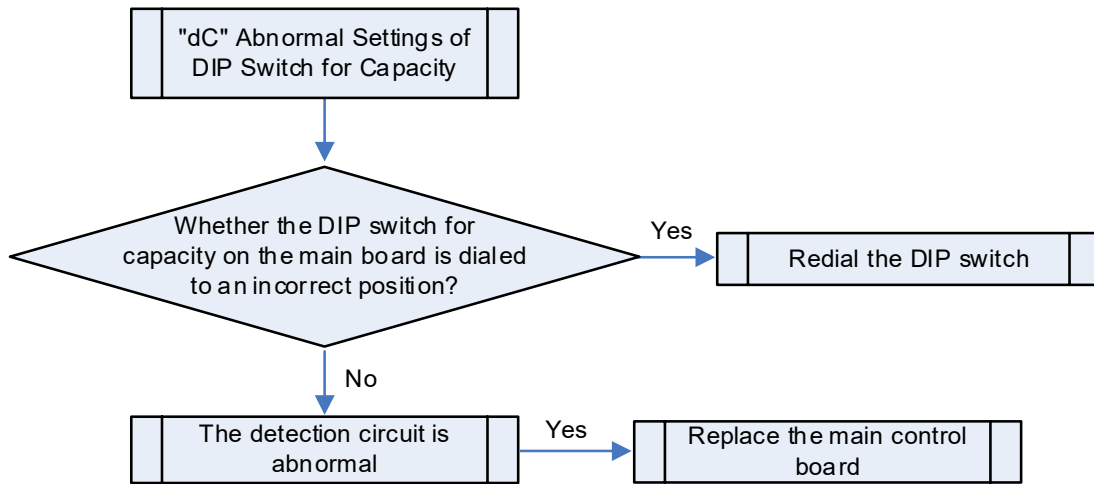

2.56 "dL" Air Outlet Temperature Sensor Fault



Fault display: wired controller of indoor unit and receiver of indoor unit display

Fault diagnosis:

The temperature sensor detection circuit samples the AD value of temperature sensor and determines the range of AD value. When the sampled AD value exceeds the limits for 5 consecutive seconds, the fault is generated.

Possible causes:

- Poor contact between the air outlet temperature sensor and the main board interface;
- Abnormal air outlet temperature sensor;
- Abnormal detection circuit.

Troubleshooting:

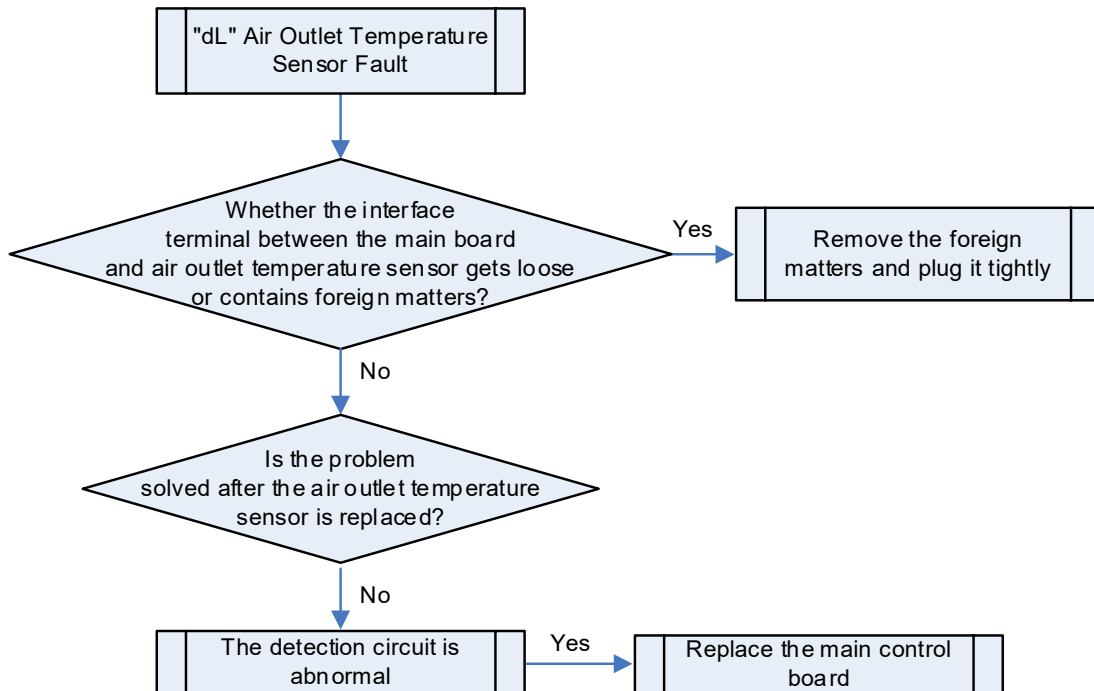

2.57 "dE" Indoor CO2 Sensor Fault (Reserved)

2.58 "dF" Temperature Sensor Error

Error display: hydro box wired controller will display 

Applicable mode: all hydro boxes

Error judgment condition and method:

Sample the AD value of temperature sensor through temperature sensor detecting circuit and judge the range of AD value. If the sampling AD value exceeds upper limit and lower limit in 30 seconds continuously, report the error

Possible reasons:

- Poor contact between temperature sensor and terminal in main board interface
- Temperature sensor is abnormal
- Detecting circuit is abnormal

Troubleshooting:

Step 1: check the hydro box main board and temperature sensor interface terminal to see if it is loose or any foreign objects inside? If yes, reconnect it after treatment;

Step 2: check if the temperature sensor is abnormal, if yes, replace the temperature sensor;

Step 3: if the above inspections are normal, the detecting circuit might be abnormal, please replace the main board.

2.59 "dJ" Water Return Temperature Sensor Error

Error display: wired controller of hydro box will display 

Applicable model: hydro box

Error judgment condition and method:

Sample the AD value of temperature sensor through temperature sensor detecting circuit and judge the range of AD value. If the sampling AD value exceeds upper limit and lower limit in 5 seconds continuously, report the error

Possible reasons:

- Poor contact between water return temperature sensor and terminal in main board interface
- Water return temperature sensor is abnormal
- Detecting circuit is abnormal

Troubleshooting:

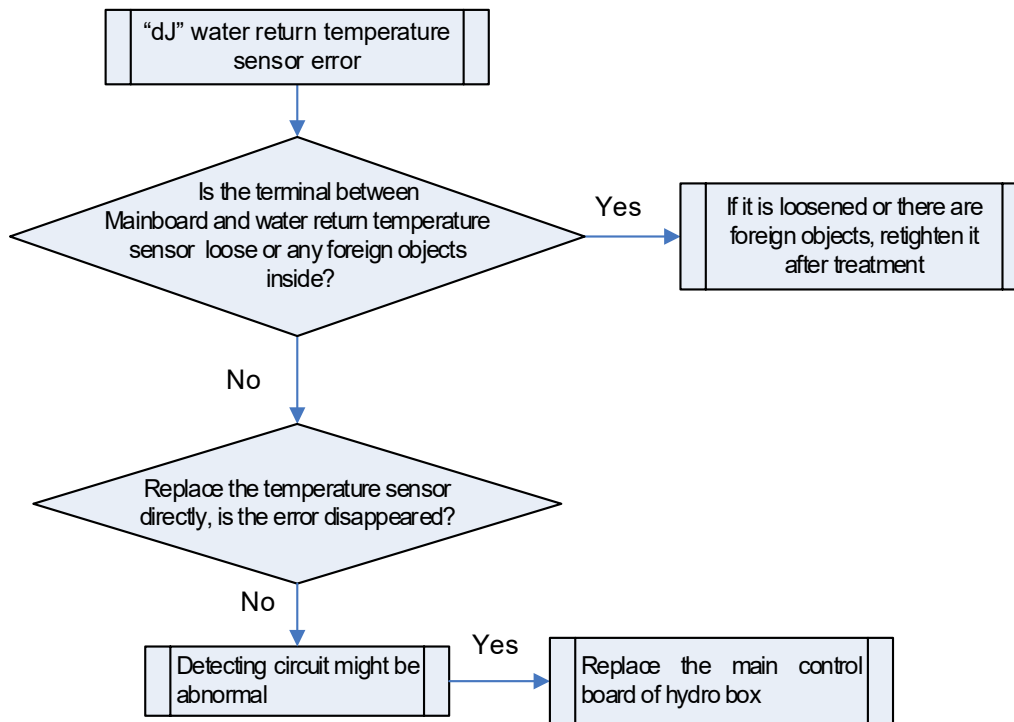

2.60 “dP” Floor Heating Water Inlet Temperature Sensor Error

Error display: hydro box wired controller 

Applicable model: all hydro boxes

Error judgment condition and method:

Sample the AD value of temperature sensor through temperature sensor detecting circuit and judge the range of AD value. If the sampling AD value exceeds upper limit and lower limit in 30 seconds continuously, report the error

Possible reasons:

- Poor contact between temperature sensor and terminal in main board interface
- Temperature sensor is abnormal
- Detecting circuit is abnormal

Troubleshooting:

Step 1: check the hydro box main board and temperature sensor interface terminal to see if it is loose or any foreign objects inside? If yes, reconnect it after treatment;

Step 2: check if the temperature sensor is abnormal, if yes, replace the temperature sensor;

Step 3: if the above inspections are normal, the detecting circuit might be abnormal, please replace the main board.

2.61 “dU” Floor Heating Water Outlet Pipe Temperature Sensor Error

Error display: wired controller of hydro box will display 

Applicable model: hydro box

Error judgment condition and method:

1) Sample the AD value of temperature sensor through temperature sensor detecting circuit and judge the range of AD value. If the sampling AD value exceeds upper limit and lower limit in 5 seconds continuously, report the error

2) After the water pump has operating for 30min, report alarm if detecting that water inlet temperature of generator is higher than water outlet temperature in 10 consecutive minutes.

Possible reasons:

■ Poor contact between floor heating outlet water pipe temperature sensor and terminal in main board interface

■ Floor heating outlet water pipe temperature sensor falls off or is abnormal

■ The circulating water in generator is not drained completely

■ Detecting circuit is abnormal

Troubleshooting:

Step 1: Is the terminal between main board of hydro box and temperature sensor loose or any foreign objects inside? If yes, retighten it after treatment;

Step 2: Is the temperature sensor loose or any foreign objects inside? If yes, retighten it or replace the temperature sensor;

Step 3: If air exist in the circulated waterway of hydro box, if yes, drain it again;

Step 4: If the above tests are normal, then the detecting circuit might be abnormal, please replace the main board.

2.62 "db" Engineering Commissioning

Fault display: main board of outdoor unit, wired controller of indoor unit and receiver of indoor unit

display 

Fault diagnosis:

This is a status code but not a fault code. It indicates that the unit is being commissioned and the indoor unit is not operational.

Possible causes: --

Troubleshooting: --

2.63 "dd" Solar Energy Temperature Sensor Error

Error display: wired controller of hydro box will display 

Applicable model: hydro box which the solar energy at function DIP code of the main board is set as "connect"

Error judgment condition and method:

Sample the AD value of temperature sensor through temperature sensor detecting circuit and judge the range of AD value. If the sampling AD value exceeds upper limit and lower limit in 5 seconds continuously, report the error

Possible reasons:

■ Poor contact between temperature sensor and terminal in main board interface

- Temperature sensor is abnormal
- Detecting circuit is abnormal

Troubleshooting:

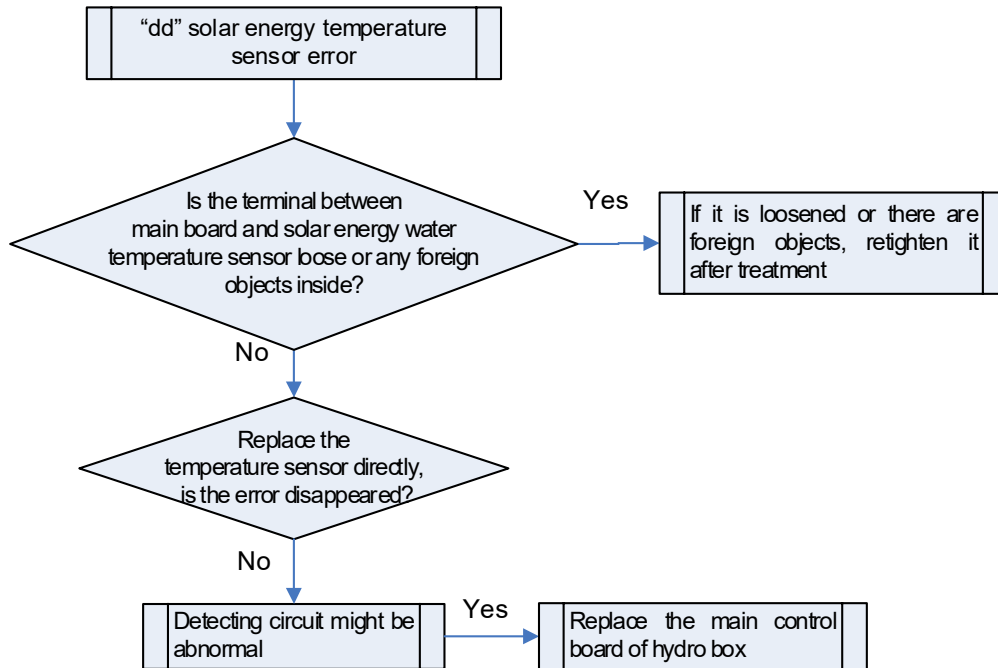

2.64 “dn” Swing Assy Error

Error display: display in the monitor software only 

Applicable model: Multi VRF indoor unit with swing assy

Error judgment condition and method:

Report alarm through judging the status of limit switch 1 and 2, When the swing structure is faulted, the indoor unit will not stop, the display board does not display error code (the error will only be embodied in CAN communication data)

Possible reasons:

- Poor contact between limit switch and terminal in main board interface
- Detecting circuit is abnormal

Troubleshooting:

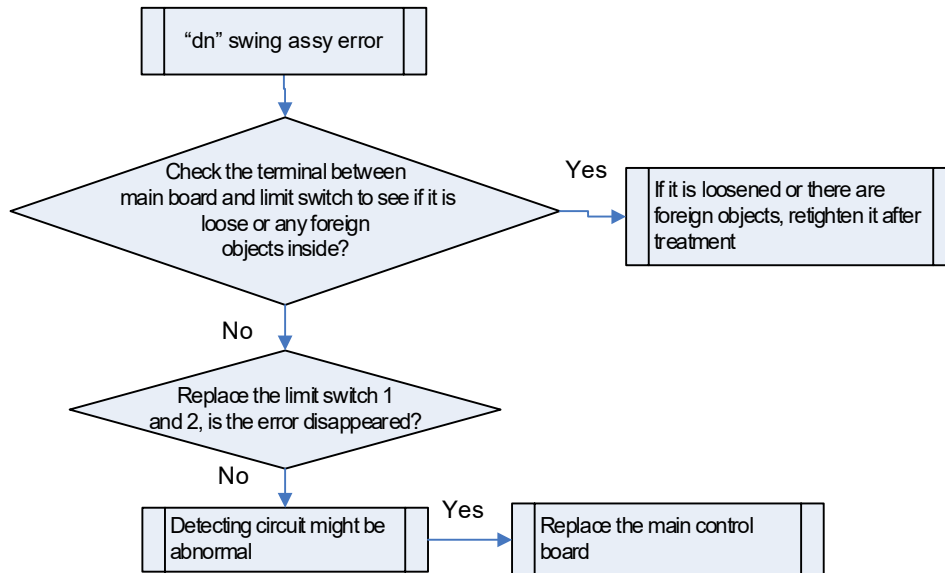

2.65 "E1" Protection in Case of Too High Pressure

Fault display: main board of outdoor unit, wired controller of indoor unit and receiver of indoor unit

display 

Fault diagnosis:

When the high pressure sensor detects that the temperature at the high pressure is greater than 65°C or the high pressure switch is disconnected, it indicates that the high pressure is too high, and the unit will stop running to ensure safe operation.

Possible causes:

- Check valve of the outdoor unit is closed;
- Abnormal high pressure sensor;
- The high pressure switch operates improperly;
- Abnormal outdoor or indoor fans;
- Clogging of indoor filter or air duct (heating mode);
- The ambient temperature where the unit operates is too high;
- Excessive refrigerant in the unit;
- Clogging of unit pipes.

Troubleshooting:

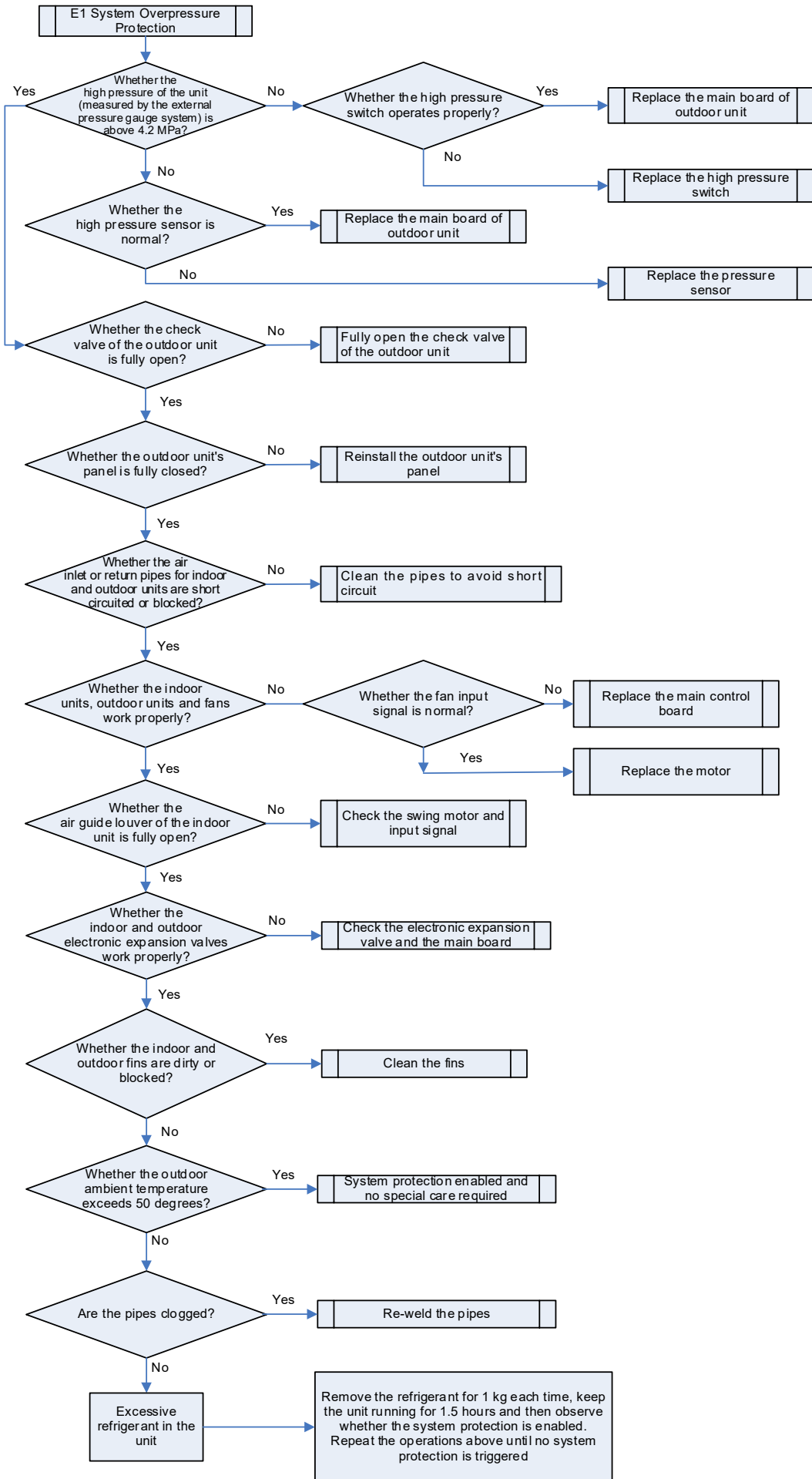

2.66 "E2" Protection in Case of Too Low Air Discharge Temperature of Compressor

Fault display: main board of outdoor unit, wired controller of indoor unit and receiver of indoor unit

display 

Fault diagnosis:

When the difference between the air discharge temperature of compressor and the temperature at the high pressure is below 10°C, the unit stops running to ensure safe operation.

Possible causes:

- The compressor's temperature sensor for air discharge operates improperly;
- The electronic expansion valve of indoor unit operates improperly in cooling mode;
- The electronic expansion valve of outdoor unit operates improperly in heating mode;
- Excessive refrigerant in the unit.

Troubleshooting:

Step 1: Check whether the air discharge pipe and shell roof temperature sensor of each compressor are installed firmly, and whether the protection sponge is fastened.

Then, check whether the resistance corresponding to each temperature is normal based on the temperature - resistance table of temperature sensor. If not, replace the temperature sensor.

Step 2: If the unit is in cooling mode:

First, inspect the indoor electronic expansion valve:

- ① When the electronic expansion valve of the indoor unit is closed to 0PLS, if the temperature difference between the inlet and outlet pipes of the indoor unit coil and the temperature at the low pressure is less than 10°C, it indicates that the unit operates improperly.

Solution: First, make sure that the EXV coil is connected properly, and then power off the unit. Power on to reset the unit and check the resetting action. If unable to reset the unit, replace the coil or the main board. If able to reset the unit normally despite the problem, replace the electronic expansion valve.

- ② Check whether the electronic expansion valve of the indoor unit operates properly: If the electronic expansion valve is open to 200PLS, the temperature of the outlet pipe of indoor unit coil is smaller than that of the inlet pipe by over 1°C, and the difference between the discharge temperature of the compressor or the shell roof temperature of the compressor and the high pressure temperature is less than 10°C.

Solution: First, make sure that the EXV coil is connected properly, and then power off the unit. Power on to reset the unit and check the resetting action. If unable to reset the unit, replace the coil or the main board. If able to reset the unit normally despite the problem, replace the electronic expansion valve.

Next, inspect the outdoor subcooler electronic expansion valve:

After confirming that the EXV coil is connected properly, power off the unit. Then power on to reset the unit and check the resetting action.

Step 3: If the unit is in heating mode, check the electronic expansion valve of the outdoor unit first.

After confirming that the EXV coil is connected properly, power off the unit. Then power on to reset the unit and check the resetting action. If unable to reset the unit, replace the coil or the main board. If

able to reset the unit normally, inspect other parts of the unit.

Step 4: Check whether the refrigerant is added in accordance with the design requirements, as excessive refrigerant may trigger system protection.

Solution: Add refrigerant in accordance with the design requirements.

2.67 "E3" System Low Pressure Protection

Fault display: main board of outdoor unit, wired controller of indoor unit and receiver of indoor unit

display 

Fault diagnosis:

The low pressure sensor detects the compressor's suction pressure. When the saturation temperature corresponding to the low pressure is below -41°C , the unit stops to ensure safe operation.

Possible causes:

- Check valve of the outdoor unit is closed;
- Abnormal low pressure sensor;
- Abnormal outdoor or indoor fans;
- Clogging of indoor filter or air duct (cooling mode);
- The ambient temperature where the unit operates is too low;
- Insufficient refrigerant in the unit;
- Clogging of unit pipes.

Troubleshooting:

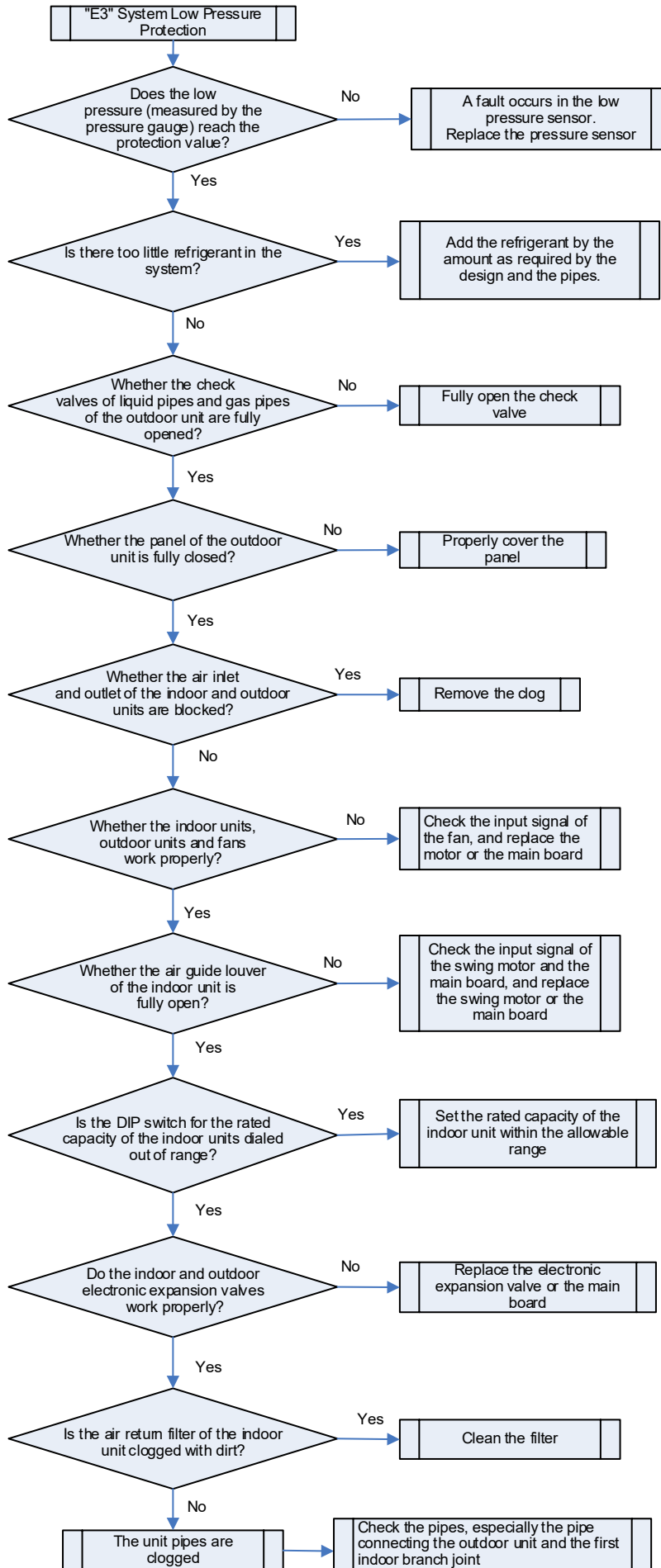

2.68 "E4" Protection in Case of Too High Air Discharge Temperature of Compressor

Fault display: main board of outdoor unit, wired controller of indoor unit and receiver of indoor unit

display 

Fault diagnosis:

When the compressor's discharge temperature detected by the temperature sensors on the discharge pipes and on the top of the compressor is above 118°C, the unit stops running to ensure safe operation.

Possible causes:

- Check valve of the outdoor unit is closed;
- The electronic expansion valve operates improperly;
- Abnormal outdoor or indoor fans;
- Clogging of indoor filter or air duct (cooling mode);
- The ambient temperature where the unit operates exceeds the limit;
- Insufficient refrigerant in the unit;
- Clogging of unit pipes.

Troubleshooting:

Step 1: Inspect and make sure that the check valves of the gas pipe and liquid pipe of the outdoor unit are fully opened.

Step 2: Power on the units based on the capacity and number of indoor units enabled previously in the case of protection state. After confirming that the EXV coil is connected properly, power off the unit. Then power on to reset the unit and check the resetting action. If unable to reset the unit, replace the coil or the main board. If able to reset the unit normally, inspect other parts of the unit.

Step 3: Power on the units based on the capacity and number of indoor units enabled previously in the case of protection state. Observe whether the indoor and outdoor fans are operating properly according to the rotational speed displayed by the commissioning software. If not, replace the motor or motor drive module (outdoor fan).

Step 4: In the case of cooling mode, check whether the filter of the indoor unit is dirty or clogged or whether the air resistance is too high (the air resistance is designed to be larger than the static pressure of the unit as required).

Step 5: Check whether the air return temperature of the unit exceeds the limit during operation (requirements in cooling mode: outdoor ambient temperature -5°C to +50°C, indoor ambient temperature 16°C to 32°C; requirements in heating mode: outdoor ambient temperature -20°C to +24°C, indoor ambient temperature 16°C to 30°C).

Step 6: Check whether the refrigerant is added in accordance with the design requirements, as insufficient refrigerant may trigger system protection.

Step 7: Power on the units based on the capacity and number of indoor units enabled previously in the case of protection state. Check whether the pipeline or expansion valve is blocked according to the parameters of the indoor and outdoor units and the temperature of the pipelines (touch with hands).

2.69 “Ed” Low Drive Module Temperature Protection

Error display: ODU main board, IDU wired controller and IDU receive light board will display 

Applicable model: GMV6 series

Error judgment condition and method:

Test module temperature through the internal sensor of IPM module, when the test value is below outdoor ambient temperature, the system will stop for protection.

Possible reasons:

- Insufficient system refrigerant
- Electronic expansion valve is abnormal
- Drive board is damaged

Troubleshooting:

Step 1: confirm if the refrigerant charge is added according to the design requirement, or any leakage exists, insufficient refrigerant might lead to protection;

Step 2: turn on the unit according to the IDU capacity and quantity in previous protection status, after confirming the coil of IDU and ODU expansion valve is correctly connected, disconnect the power, then re-energize for reset and check the reset action. If it is abnormal, replace the coil or main board; if it is normal, check other items;

Step 3: if no problems are found in other inspection steps, the drive board might be damaged, IPM temperature test is abnormal, please replace the drive board.

2.70 "F0" Poor Main Board of Outdoor Unit

Fault display: main board of outdoor unit, wired controller of indoor unit and receiver of indoor unit

display 

Fault diagnosis:

Check whether the address chip, memory chip and clock chip of the main board of the outdoor unit can be read properly. If not, the fault is generated.

Possible causes:

- Abnormal address chip;
- Abnormal memory chip;
- Abnormal clock chip.

Troubleshooting:

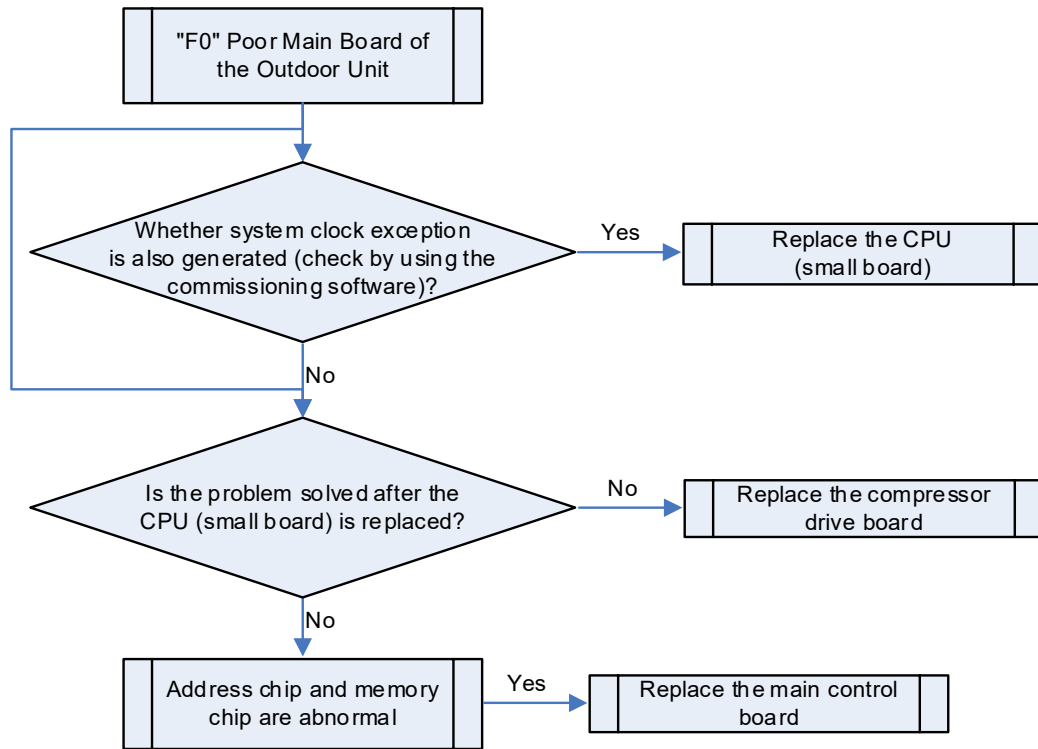

2.71 "F1" High-pressure Sensor Fault

Fault display: main board of outdoor unit, wired controller of indoor unit and receiver of indoor unit



Fault diagnosis:

The sensor detection circuit samples the AD value of high pressure sensor and determines the range of AD value. When the sampled AD value exceeds the limits for 30 consecutive seconds, the fault is generated.

Possible causes:

- Poor contact between the high pressure sensor and the main board interface;
- Poor contact between high pressure sensor and part where the pressure is detected;
- Abnormal high pressure sensor;
- Abnormal sensor detection circuit.

Troubleshooting:

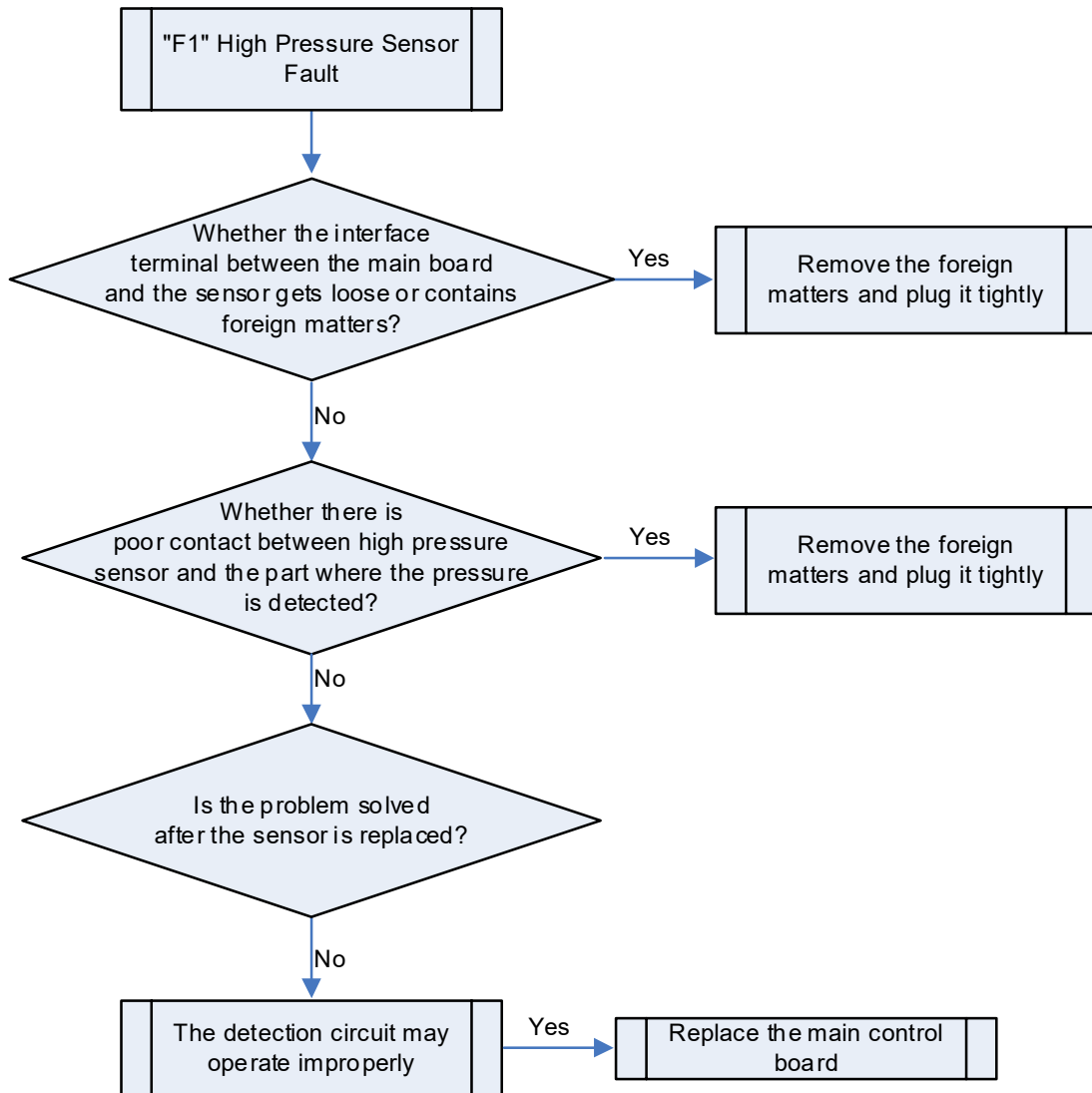

2.72 "F3" Low Pressure Sensor Fault

Fault display: main board of outdoor unit, wired controller of indoor unit and receiver of indoor unit



Fault diagnosis:

The sensor detection circuit samples the AD value of low pressure sensor and determines the range of AD value. When the sampled AD value exceeds the limits for 30 consecutive seconds, the fault is generated.

Possible causes:

- Poor contact between the low pressure sensor and the main board interface;
- Poor contact between low pressure sensor and part where the pressure is detected;
- Abnormal low pressure sensor;
- Abnormal low pressure sensor detection circuit.

Troubleshooting:

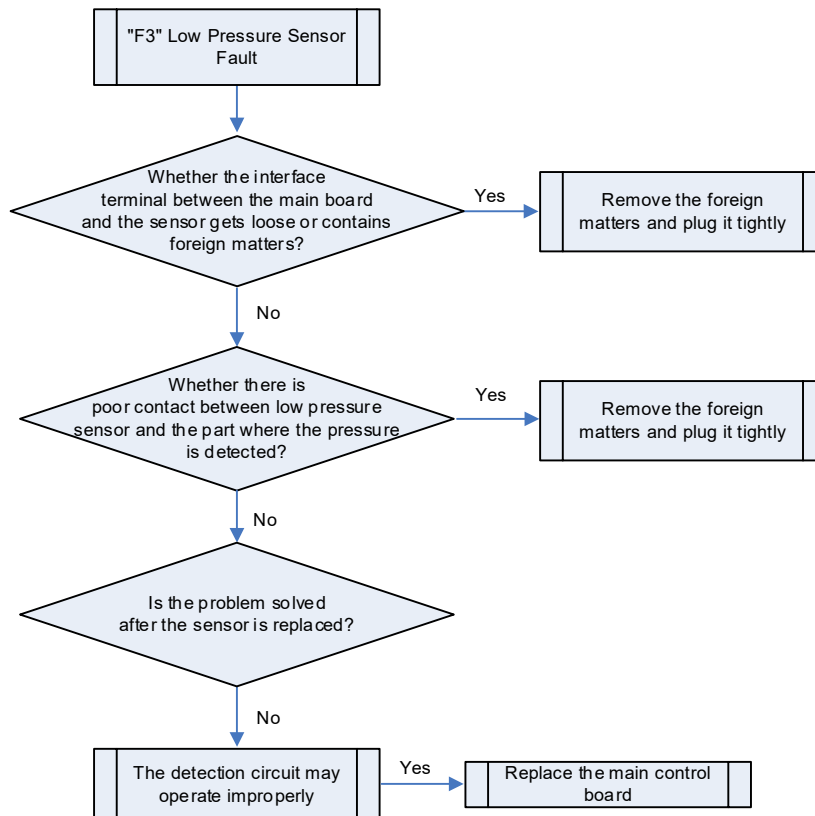

2.73 "F5" Discharge Temperature Sensor Fault of Compressor 1

Fault display: main board of outdoor unit, wired controller of indoor unit and receiver of indoor unit



Fault diagnosis:

The temperature sensor detection circuit samples the AD value of temperature sensor and determines the range of AD value. When the sampled AD value exceeds the limits for 30 consecutive seconds, the fault is generated.

Possible causes:

- Poor contact between the discharge temperature sensor and the main board interface;
- Abnormal discharge temperature sensor;
- Abnormal detection circuit.

Troubleshooting:

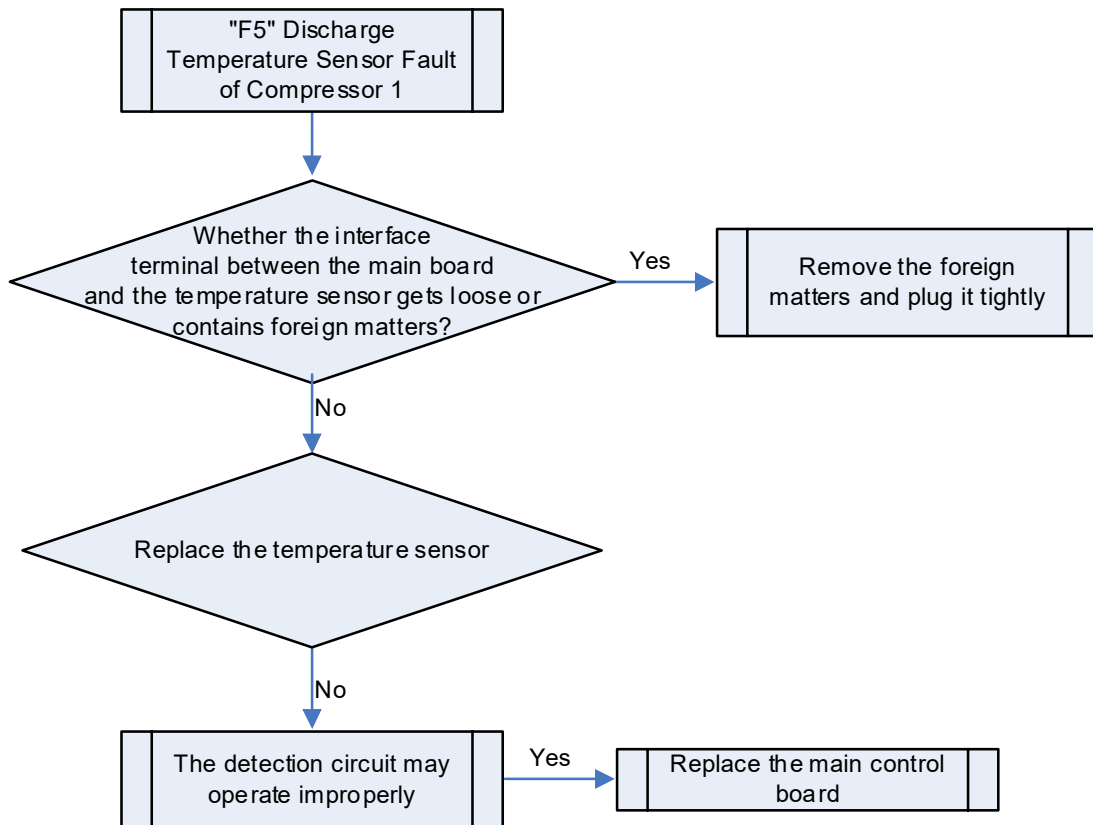

2.74 "F6" Discharge Temperature Sensor Fault of Compressor 2

Fault display: main board of outdoor unit, wired controller of indoor unit and receiver of indoor unit



Fault diagnosis:

The temperature sensor detection circuit samples the AD value of temperature sensor and determines the range of AD value. When the sampled AD value exceeds the limits for 30 consecutive seconds, the fault is generated.

Possible causes:

- Poor contact between the discharge temperature sensor and the main board interface;
- Abnormal discharge temperature sensor;
- Abnormal detection circuit.

Troubleshooting:

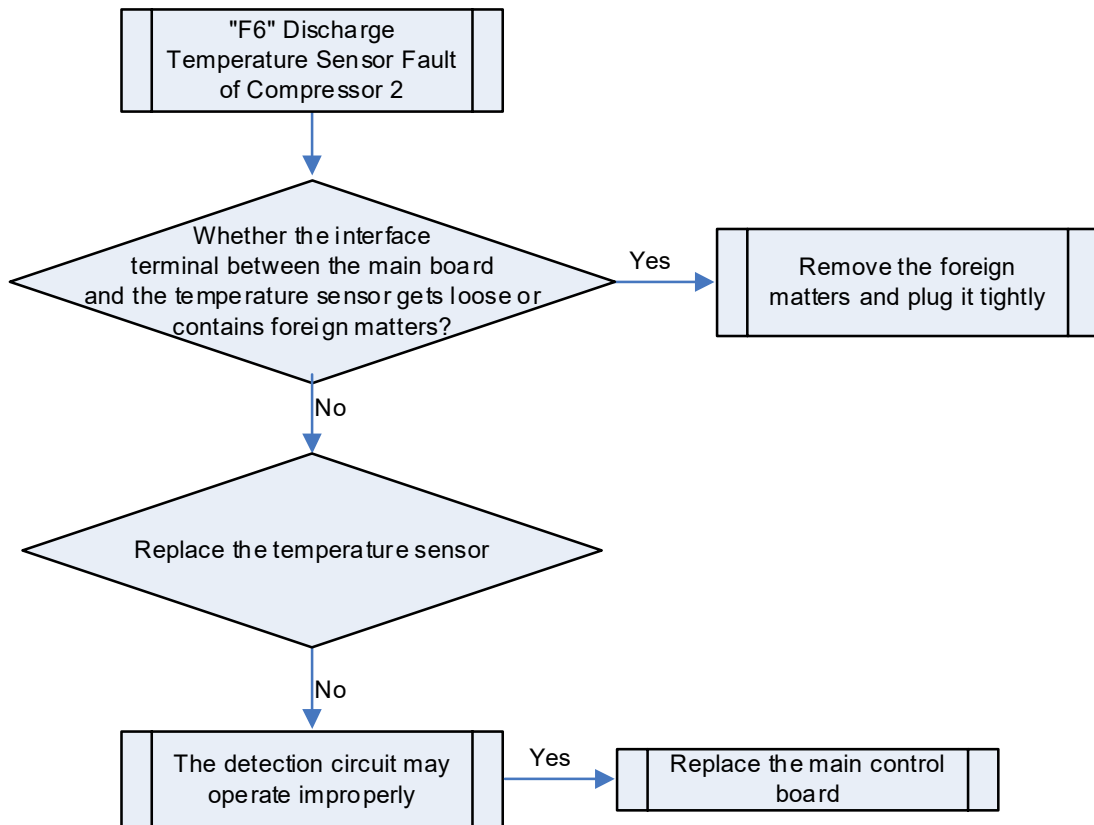

2.75 "F7" Discharge Temperature Sensor Fault of Compressor 3

Fault display: main board of outdoor unit, wired controller of indoor unit and receiver of indoor unit



Fault diagnosis:

The temperature sensor detection circuit samples the AD value of temperature sensor and determines the range of AD value. When the sampled AD value exceeds the limits for 30 consecutive seconds, the fault is generated.

Possible causes:

- Poor contact between the discharge temperature sensor and the main board interface;
- Abnormal discharge temperature sensor;
- Abnormal detection circuit.

Troubleshooting:

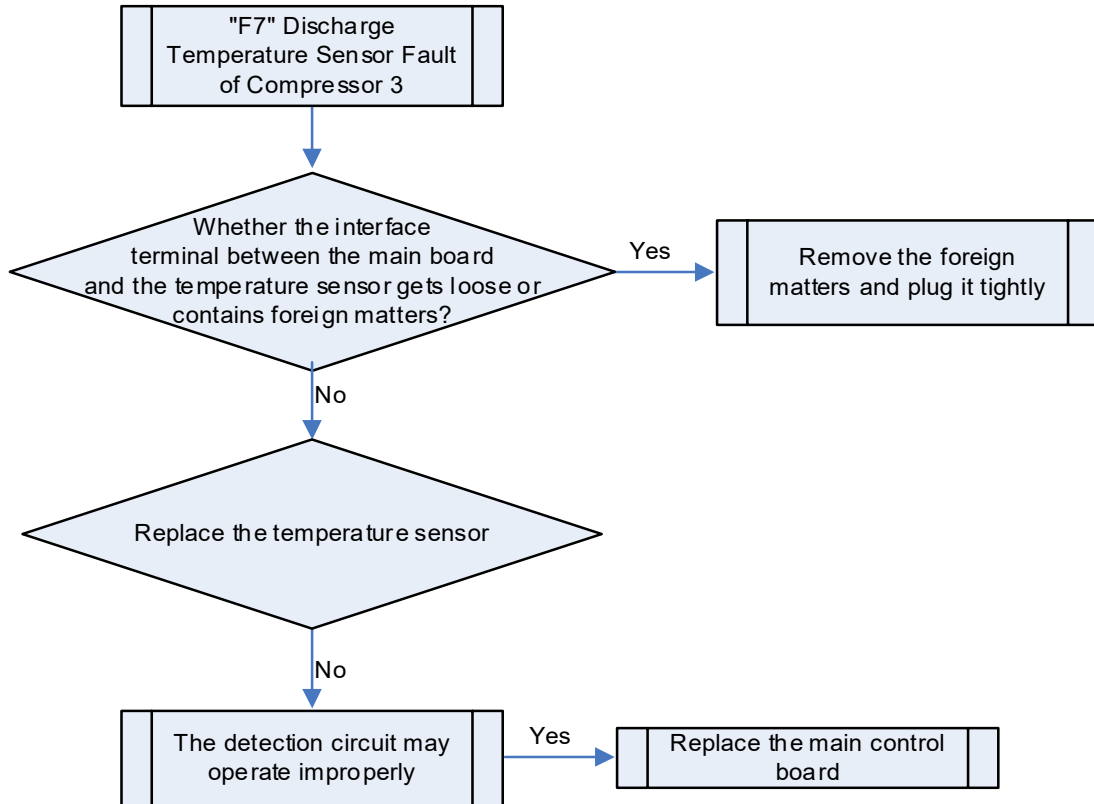

2.76 "F8" Discharge Temperature Sensor Fault of Compressor 4

Fault display: main board of outdoor unit, wired controller of indoor unit and receiver of indoor unit



Fault diagnosis:

The temperature sensor detection circuit samples the AD value of temperature sensor and determines the range of AD value. When the sampled AD value exceeds the limits for 30 consecutive seconds, the fault is generated.

Possible causes:

- Poor contact between the discharge temperature sensor and the main board interface;
- Abnormal discharge temperature sensor;
- Abnormal detection circuit.

Troubleshooting:

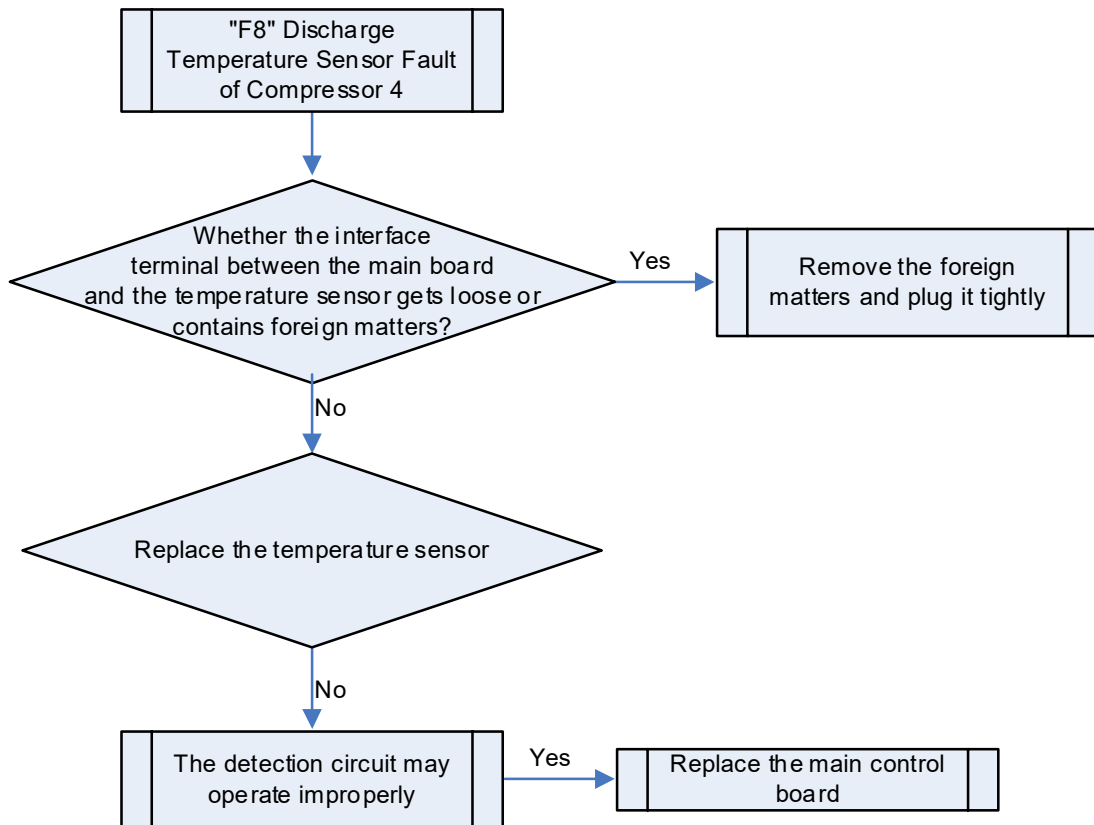

2.77 "F9" Discharge Temperature Sensor Fault of Compressor 5

Fault display: main board of outdoor unit, wired controller of indoor unit and receiver of indoor unit



Fault diagnosis:

The temperature sensor detection circuit samples the AD value of temperature sensor and determines the range of AD value. When the sampled AD value exceeds the limits for 30 consecutive seconds, the fault is generated.

Possible causes:

- Poor contact between the discharge temperature sensor and the main board interface;
- Abnormal discharge temperature sensor;
- Abnormal detection circuit.

Troubleshooting:

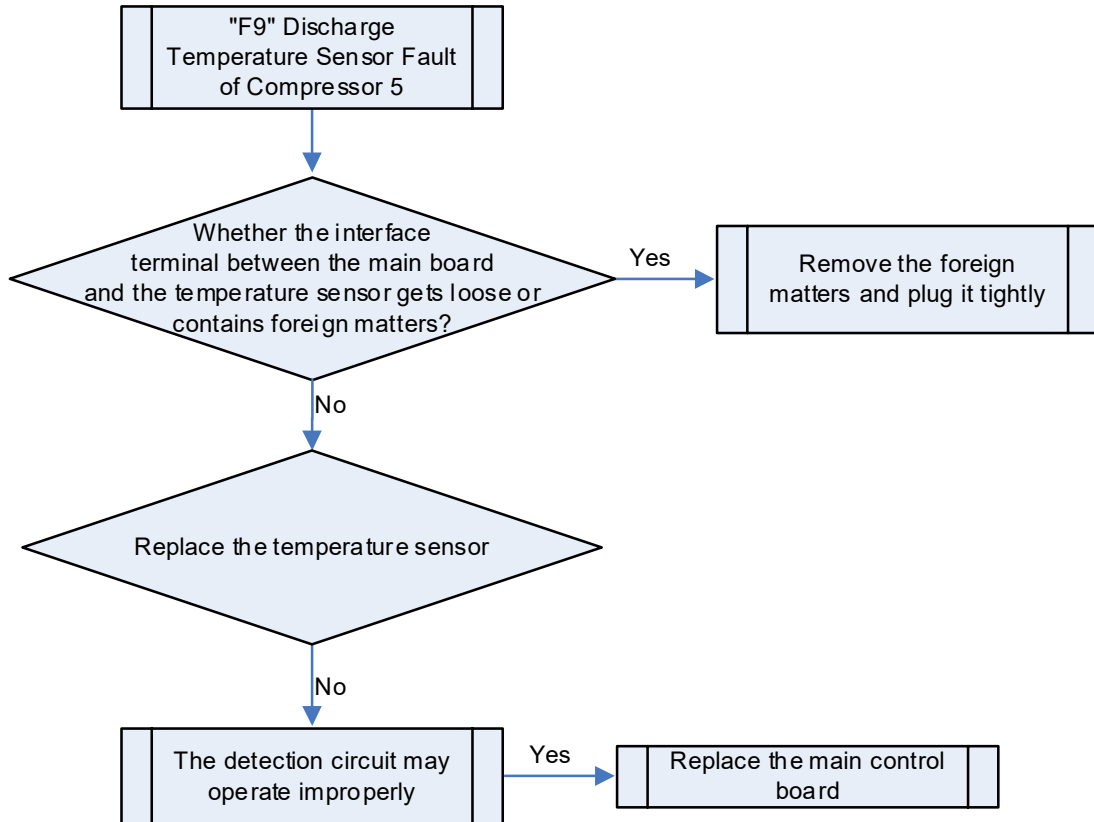

2.78 "FA" Discharge Temperature Sensor Fault of Compressor 6

Fault display: main board of outdoor unit, wired controller of indoor unit and receiver of indoor unit



Fault diagnosis:

The temperature sensor detection circuit samples the AD value of temperature sensor and determines the range of AD value. When the sampled AD value exceeds the limits for 30 consecutive seconds, the fault is generated.

Possible causes:

- Poor contact between the discharge temperature sensor and the main board interface;
- Abnormal discharge temperature sensor;
- Abnormal detection circuit.

Troubleshooting:

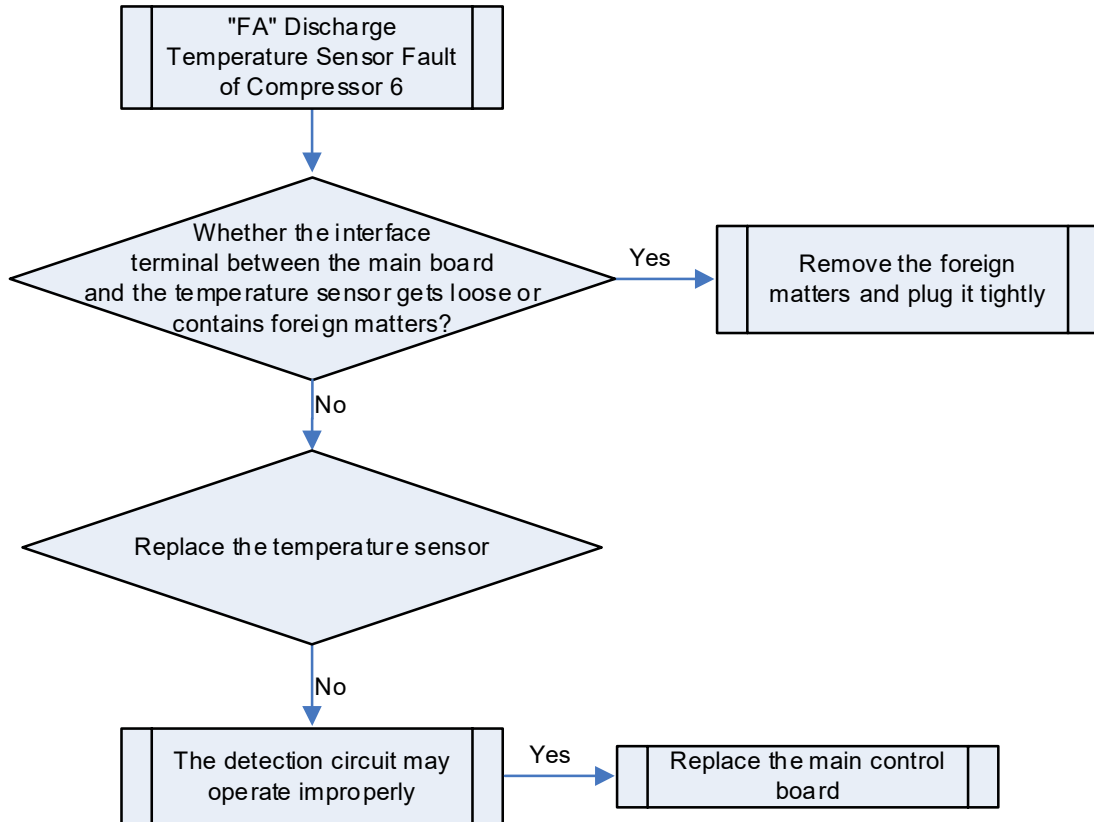

2.79 "FH" Abnormal Current Sensor of Compressor 1

Fault display: main board of outdoor unit, wired controller of indoor unit and receiver of indoor unit

display 

Fault diagnosis:

The circuit detection circuit samples the AD value and determines the range of AD value. When the sampled AD value exceeds the limits for 3 consecutive seconds, the fault is generated.

Possible causes:

- Poor contact between the circuit sensor and the main board interface;
- Abnormal small board of circuit sensor;
- Abnormal detection circuit.

Troubleshooting:

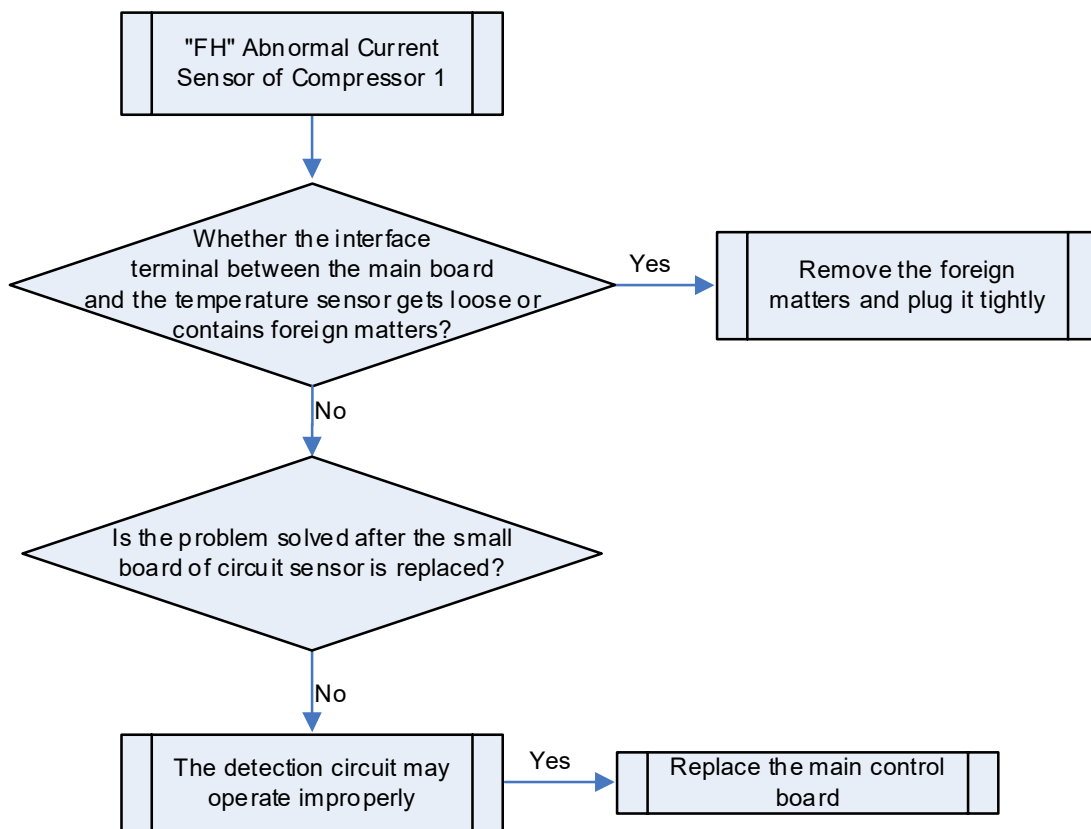

2.80 "FC" Abnormal Current Sensor of Compressor 2

Fault display: main board of outdoor unit, wired controller of indoor unit and receiver of indoor unit



Fault diagnosis:

The circuit detection circuit samples the AD value and determines the range of AD value. When the sampled AD value exceeds the limits for 3 consecutive seconds, the fault is generated.

Possible causes:

- Poor contact between the circuit sensor and the main board interface;
- Abnormal small board of circuit sensor;
- Abnormal detection circuit.

Troubleshooting:

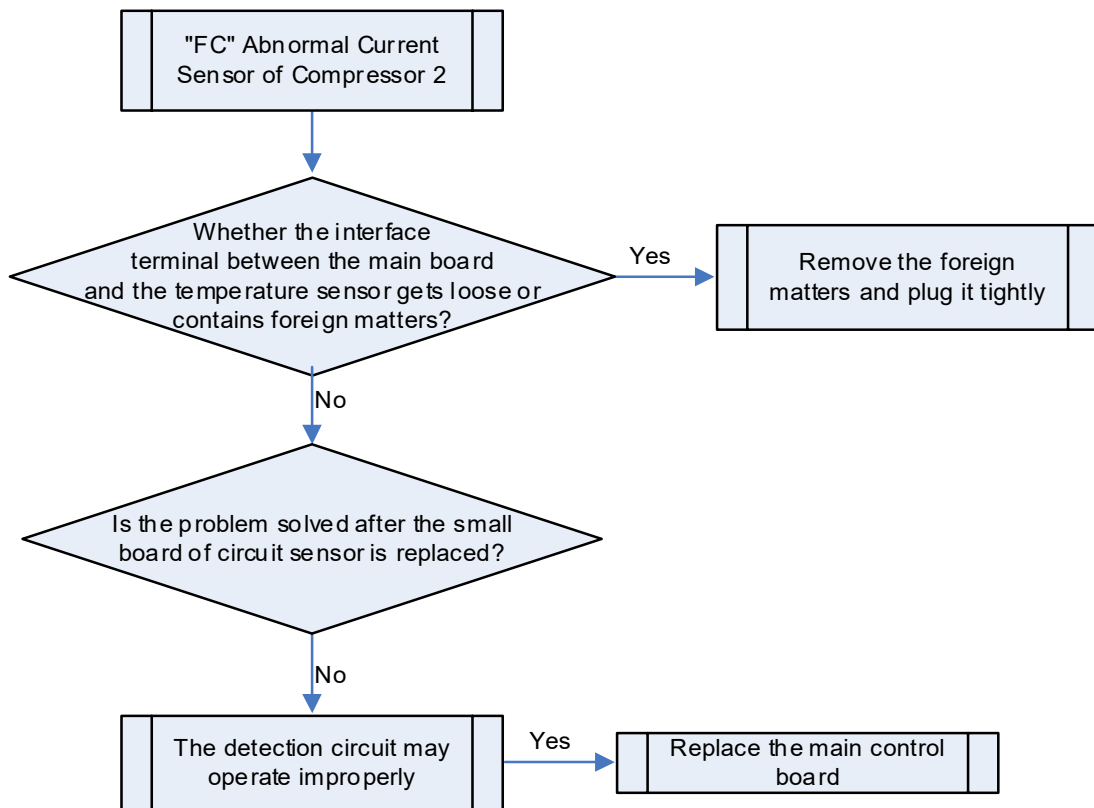

2.81 "FL" Abnormal Current Sensor of Compressor 3

Fault display: main board of outdoor unit, wired controller of indoor unit and receiver of indoor unit



Fault diagnosis:

The circuit detection circuit samples the AD value and determines the range of AD value. When the sampled AD value exceeds the limits for 3 consecutive seconds, the fault is generated.

Possible causes:

- Poor contact between the circuit sensor and the main board interface;
- Abnormal small board of circuit sensor;
- Abnormal detection circuit.

Troubleshooting:

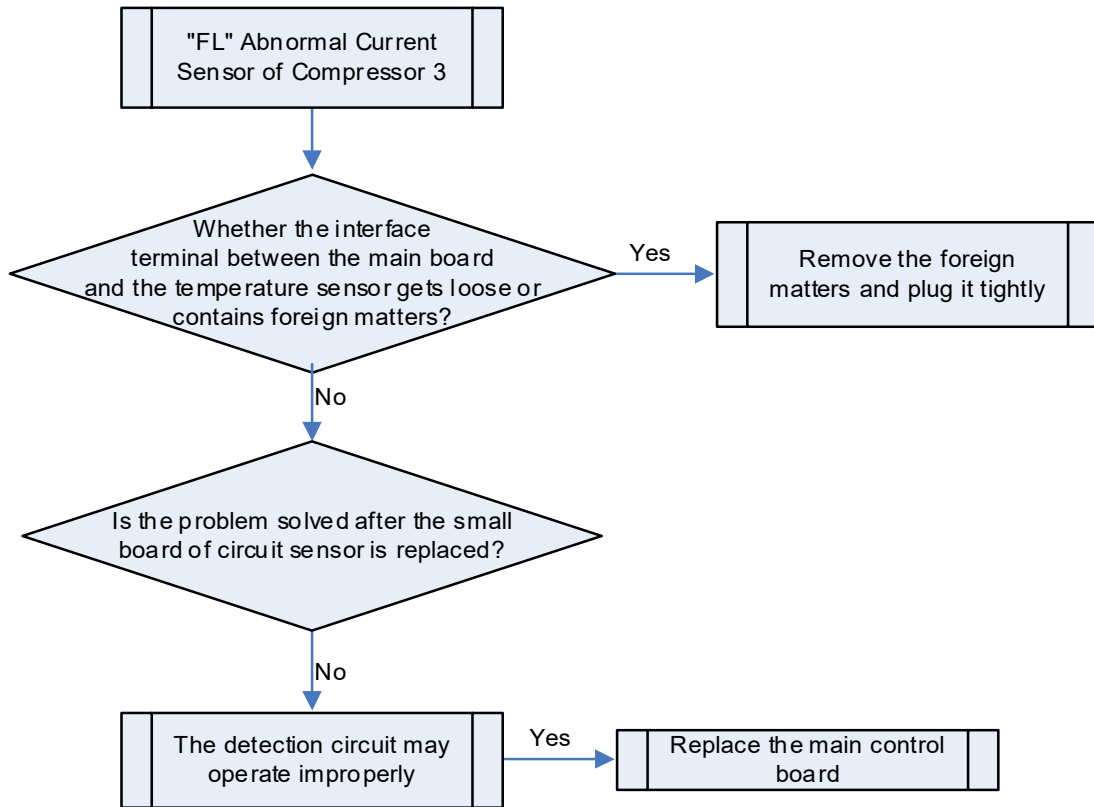

2.82 "FE" Abnormal Current Sensor of Compressor 4

Fault display: main board of outdoor unit, wired controller of indoor unit and receiver of indoor unit



Fault diagnosis:

The circuit detection circuit samples the AD value and determines the range of AD value. When the sampled AD value exceeds the limits for 3 consecutive seconds, the fault is generated.

Possible causes:

- Poor contact between the circuit sensor and the main board interface;
- Abnormal small board of circuit sensor;
- Abnormal detection circuit.

Troubleshooting:

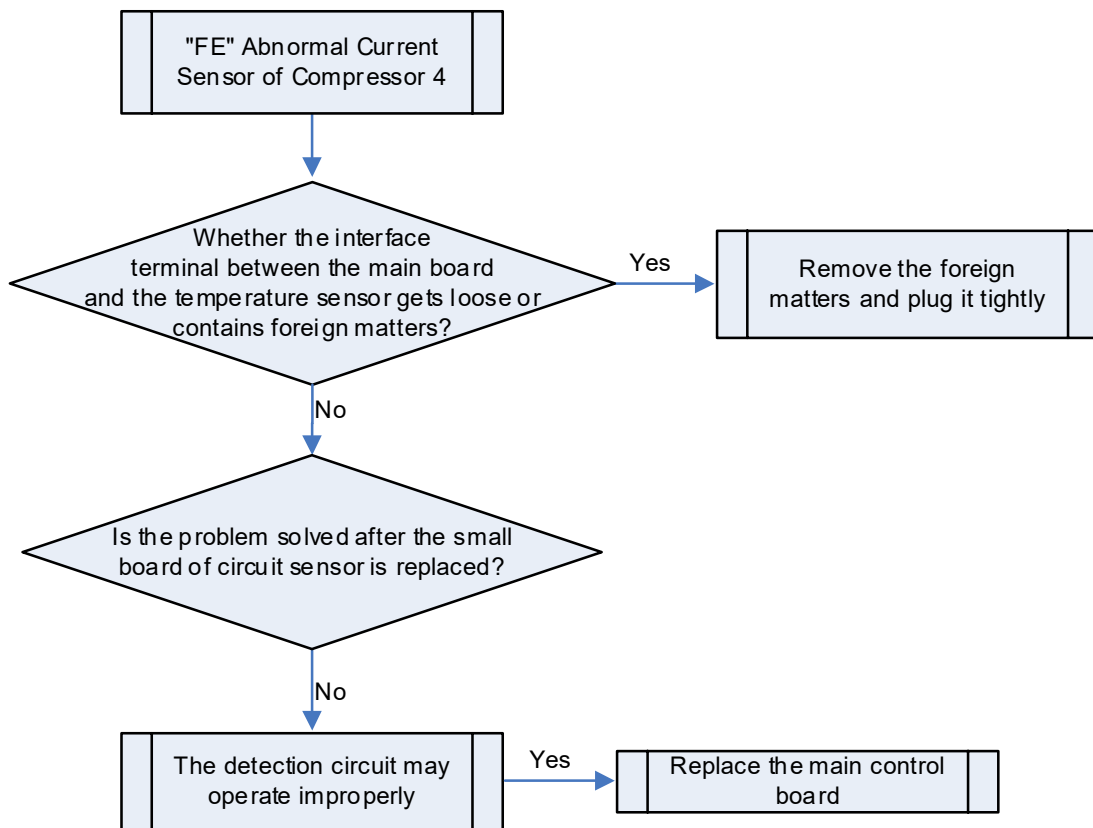

2.83 "FF" Abnormal Current Sensor of Compressor 5

Fault display: main board of outdoor unit, wired controller of indoor unit and receiver of indoor unit



Fault diagnosis:

The circuit detection circuit samples the AD value and determines the range of AD value. When the sampled AD value exceeds the limits for 3 consecutive seconds, the fault is generated.

Possible causes:

- Poor contact between the circuit sensor and the main board interface;
- Abnormal small board of circuit sensor;
- Abnormal detection circuit.

Troubleshooting:

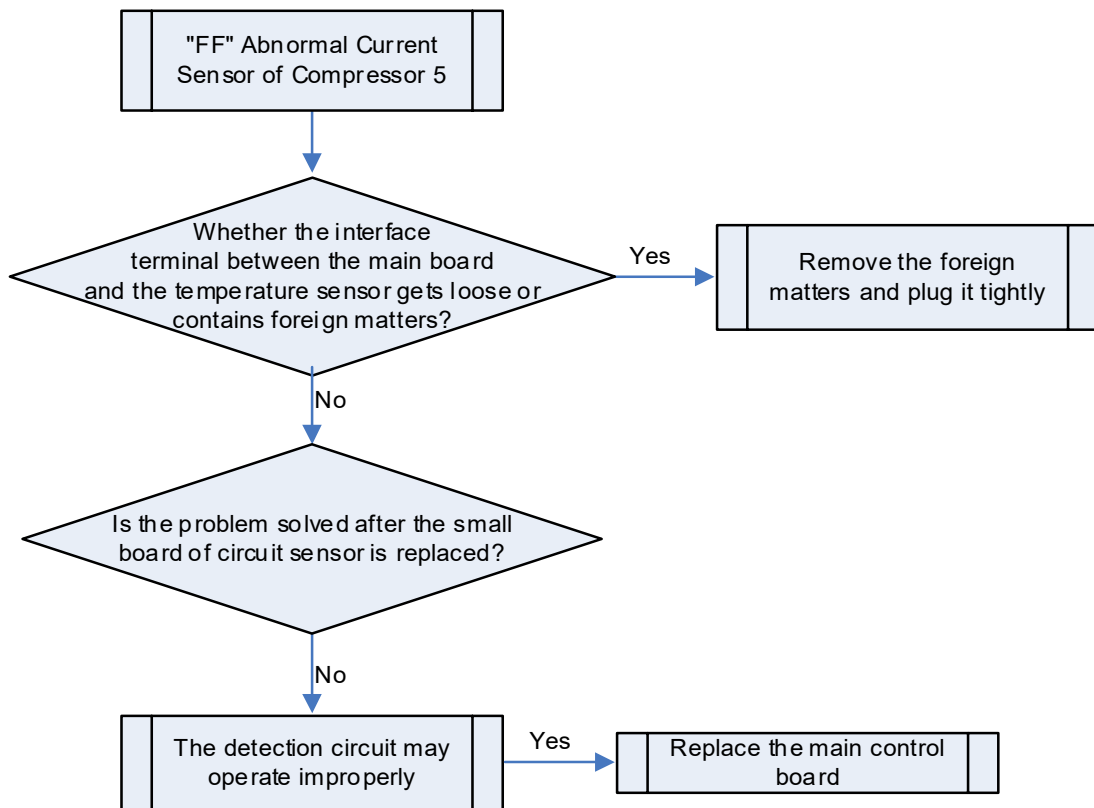

2.84 "FJ" Abnormal Current Sensor of Compressor 6

Fault display: main board of outdoor unit, wired controller of indoor unit and receiver of indoor unit



Fault diagnosis:

The circuit detection circuit samples the AD value and determines the range of AD value. When the sampled AD value exceeds the limits for 3 consecutive seconds, the fault is generated.

Possible causes:

- Poor contact between the circuit sensor and the main board interface;
- Abnormal small board of circuit sensor;
- Abnormal detection circuit.

Troubleshooting:

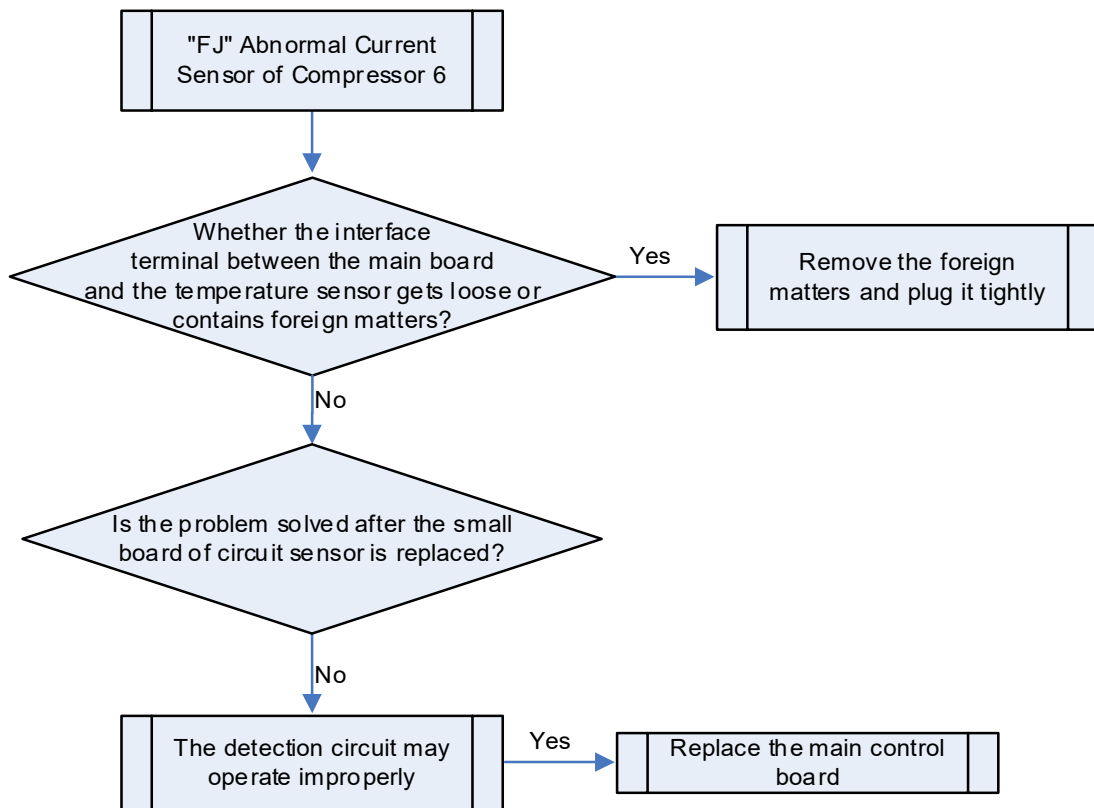

2.85 "FU" Shell Roof Temperature Sensor Fault of Compressor 1

Fault display: main board of outdoor unit, wired controller of indoor unit and receiver of indoor unit



Fault diagnosis:

The temperature sensor detection circuit samples the AD value of temperature sensor and determines the range of AD value. When the sampled AD value exceeds the limits for 30 consecutive seconds, the fault is generated.

Possible causes:

- Poor contact between the shell roof temperature sensor and the main board interface;
- Abnormal shell roof temperature sensor;
- Abnormal detection circuit.

Troubleshooting:

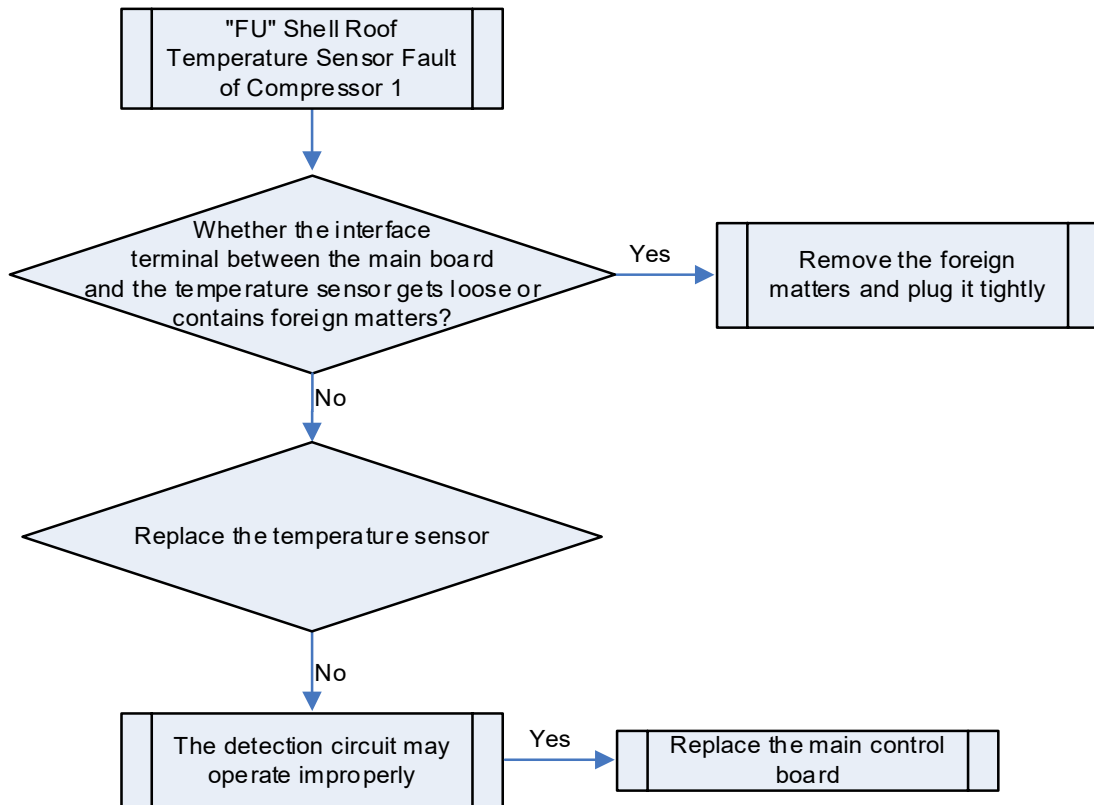

2.86 "Fb" Shell Roof Temperature Sensor Fault of Compressor 2

Fault display: main board of outdoor unit, wired controller of indoor unit and receiver of indoor unit



Fault diagnosis:

The temperature sensor detection circuit samples the AD value of temperature sensor and determines the range of AD value. When the sampled AD value exceeds the limits for 30 consecutive seconds, the fault is generated.

Possible causes:

- Poor contact between the shell roof temperature sensor and the main board interface;
- Abnormal shell roof temperature sensor;
- Abnormal detection circuit.

Troubleshooting:

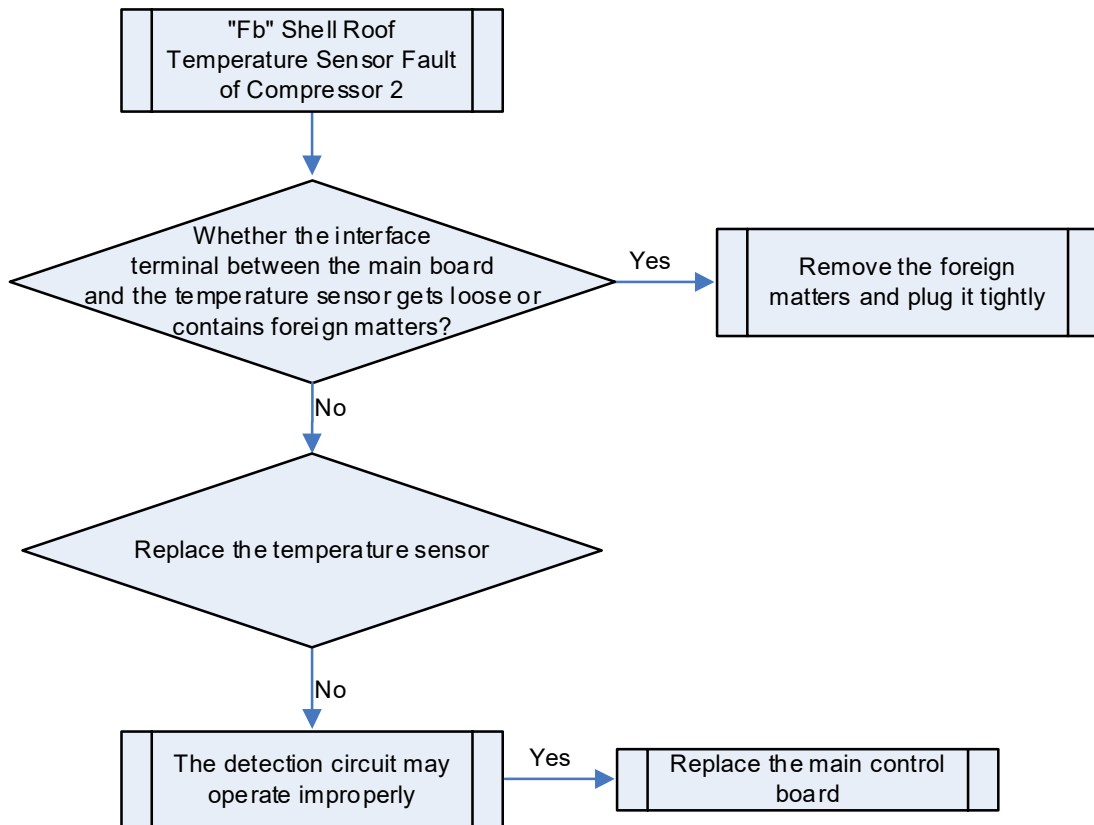

2.87 "H0" Fan Drive Board Fault



Fault display: wired controller of indoor unit displays

Fault diagnosis:

Check the fault code displayed on the wired controller of the indoor unit. If the wired controller displays H0, check the fault code displayed on the 2-digit digital LED of the main control board of the outdoor unit, based on which you are able to identify the specific fault of the fan drive board. Then, troubleshoot the fault according to the corresponding troubleshooting methods.

Possible causes:

- Fan drive module reset protection (2-digit digital LED of the main control board of the outdoor unit displays H3);
- Temperature sensor fault of fan drive (2-digit digital LED of the main control board of the outdoor unit displays H7);
- IPM over temperature protection for the fan drive (2-digit digital LED of the main control board of the outdoor unit displays H8);
- Current detection circuit fault of fan drive (2-digit digital LED of the main control board of the outdoor unit displays HC);
- Charging loop fault of fan drive (2-digit digital LED of the main control board of the outdoor unit displays HF);
- Loss of synchronization protection for the inverter fan (2-digit digital LED of the main control board of the outdoor unit displays H9);
- Inverter fan startup failure (2-digit digital LED of the main control board of the outdoor unit displays HJ).

Troubleshooting:

Step 1: Check the fault code displayed on the wired controller of the indoor unit.

Step 2: Check the fault code displayed on the 2-digit digital LED of the outdoor unit at the same time.

Step 3: Troubleshoot according to the fault code displayed on the 2-digit digital LED of the outdoor unit (troubleshooting procedures may vary depending on the fault).

2.88 "H1" Abnormal Fan Drive Board



Fault display: wired controller of indoor unit displays

Fault diagnosis:

Check the fault code displayed on the wired controller of the indoor unit. If the wired controller displays H1, check the fault code displayed on the 2-digit digital LED of the main control board of the outdoor unit, based on which you are able to identify the specific fault of the fan drive board. Then, troubleshoot the fault according to the corresponding troubleshooting methods.

Possible causes:

- IPM module protection for the fan drive (2-digit digital LED of the main control board of the outdoor unit displays H6);

- Inverter fan over-current protection (2-digit digital LED of the main control board of the outdoor unit displays H5);

- Communication fault of fan drive (2-digit digital LED of the main control board of the outdoor unit displays C3).

Troubleshooting:

Step 1: Check the fault code displayed on the wired controller of the indoor unit.

Step 2: Check the fault code displayed on the 2-digit digital LED of the outdoor unit at the same time.

Step 3: Troubleshoot according to the fault code displayed on the 2-digit digital LED of the outdoor unit (troubleshooting procedures may vary depending on the fault).

2.89 "H2" Power Voltage Protection for the Fan Drive Board



Fault display: wired controller of indoor unit displays

Fault diagnosis:

Check the fault code displayed on the wired controller of the indoor unit. If the wired controller displays H2, check the fault code displayed on the 2-digit digital LED of the main control board of the outdoor unit, based on which you are able to identify the specific fault of the fan drive board. Then, troubleshoot the fault according to the corresponding troubleshooting methods.

Possible causes:

- Over voltage protection for the DC bus of fan drive (2-digit digital LED of the main control board of the outdoor unit displays HH);

- Under voltage protection for the DC bus of fan drive (2-digit digital LED of the main control board of the outdoor unit displays HL).

Troubleshooting:

Step 1: Check the fault code displayed on the wired controller of the indoor unit.

Step 2: Check the fault code displayed on the 2-digit digital LED of the outdoor unit at the same time.

Step 3: Troubleshoot according to the fault code displayed on the 2-digit digital LED of the outdoor unit (troubleshooting procedures may vary depending on the fault).

2.90 "H3" Reset Protection for the Fan Drive Module

Fault display: wired controller of indoor unit displays



Fault diagnosis:

If the fault code displayed on the 2-digit digital LED of the outdoor unit's main control board is H3, it indicates the reset protection for the fan drive board.

Possible causes:

- The fan drive board operates improperly

Troubleshooting:

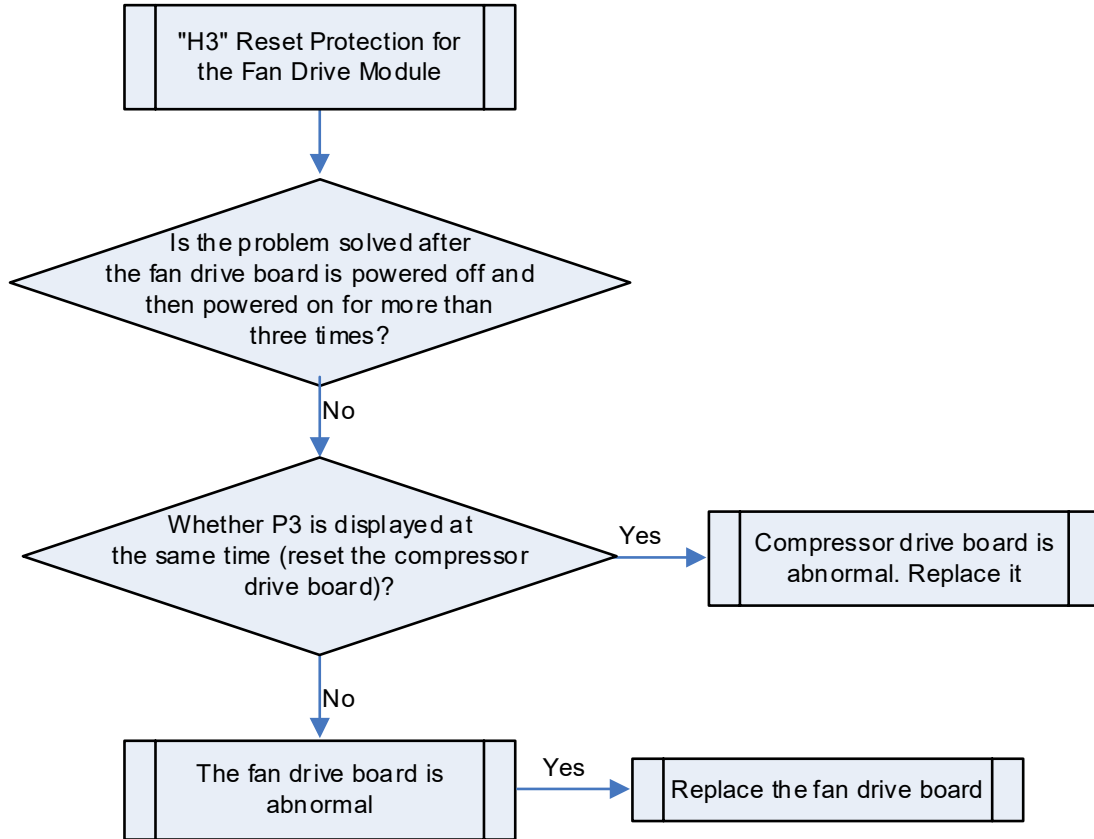

2.91 "H5" Inverter Fan Over-current Protection



Fault display: main board of outdoor unit displays

Fault diagnosis:

If the fault code displayed on the 2-digit digital LED of the outdoor unit's main control board is H5, it indicates the over-current protection for the inverter fan.

Possible causes:

- Poor contact of fan's UVW cables;
- The fan is damaged;
- The blades are stuck (the blades are blocked or the motor shaft gets rusty);
- The fan drive board operates improperly.

Troubleshooting:

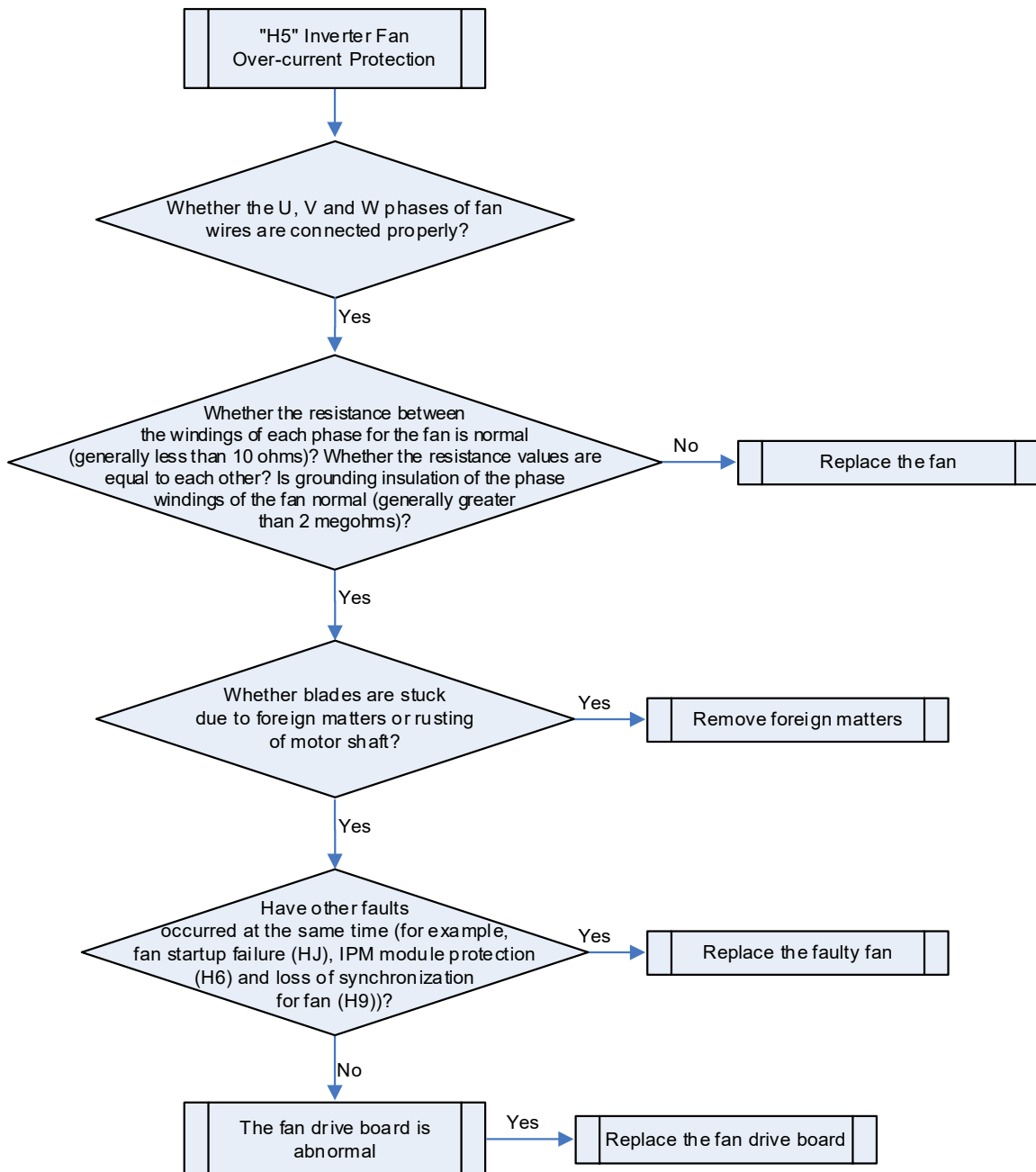

2.92 "H6" IPM Module Protection for Fan Drive



Fault display: main board of outdoor unit displays

Fault diagnosis:

If the fault code displayed on the 2-digit digital LED of the outdoor unit's main control board is H6, it indicates the IPM module protection for the fan drive.

Possible causes:

- Poor contact of fan's UVW cables;
- The fan is damaged;
- The blades are stuck (the blades are blocked or the motor shaft gets rusty);
- The fan drive board operates improperly.

Troubleshooting:

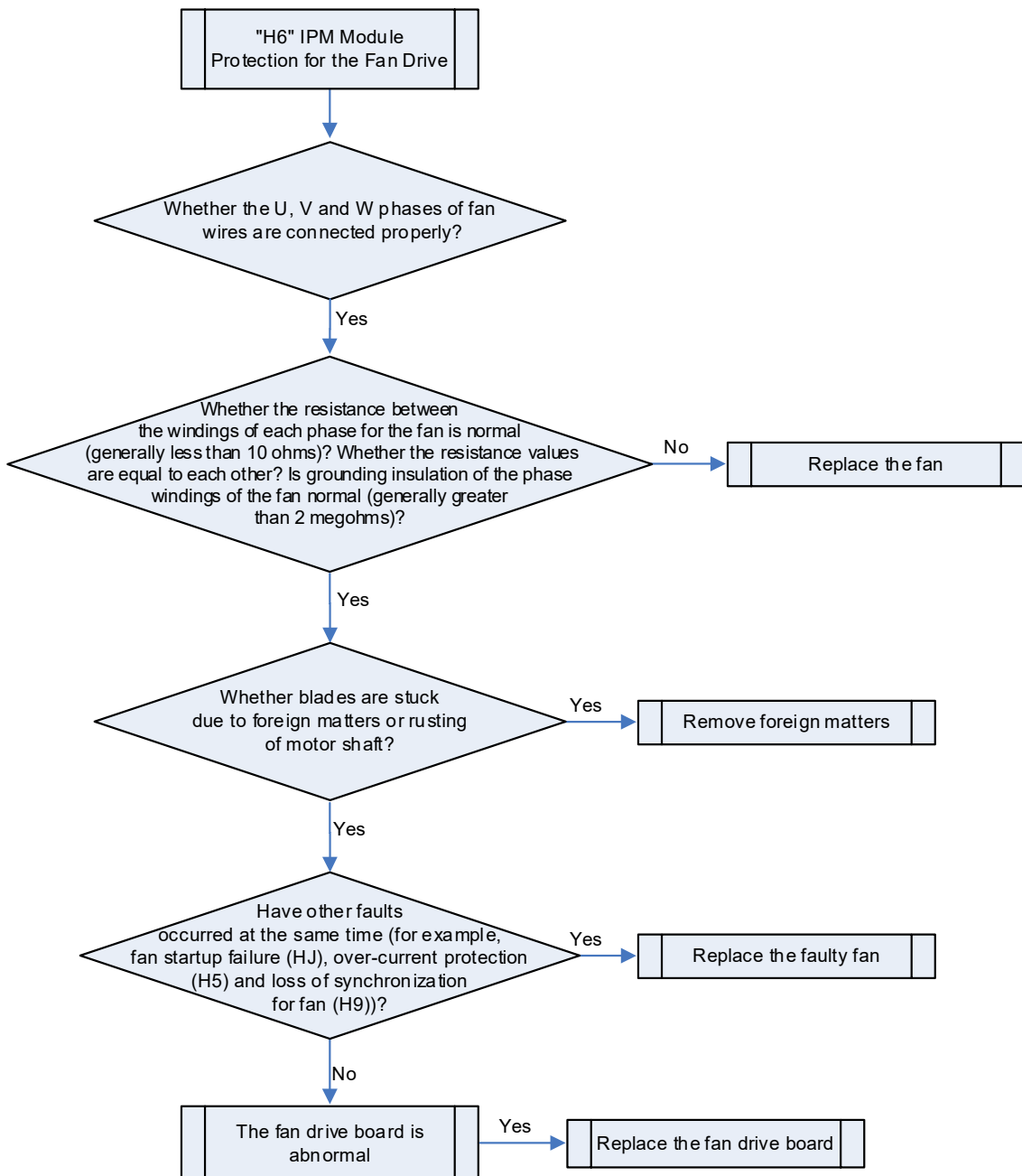

2.93 "H7" Temperature Sensor Fault of Fan Drive



Fault display: main board of outdoor unit displays

Fault diagnosis:

If the fault code displayed on the 2-digit digital LED of the outdoor unit's main control board is H7, it indicates the temperature sensor fault for the fan drive.

Possible causes:

- The fan drive board operates improperly.

Troubleshooting:

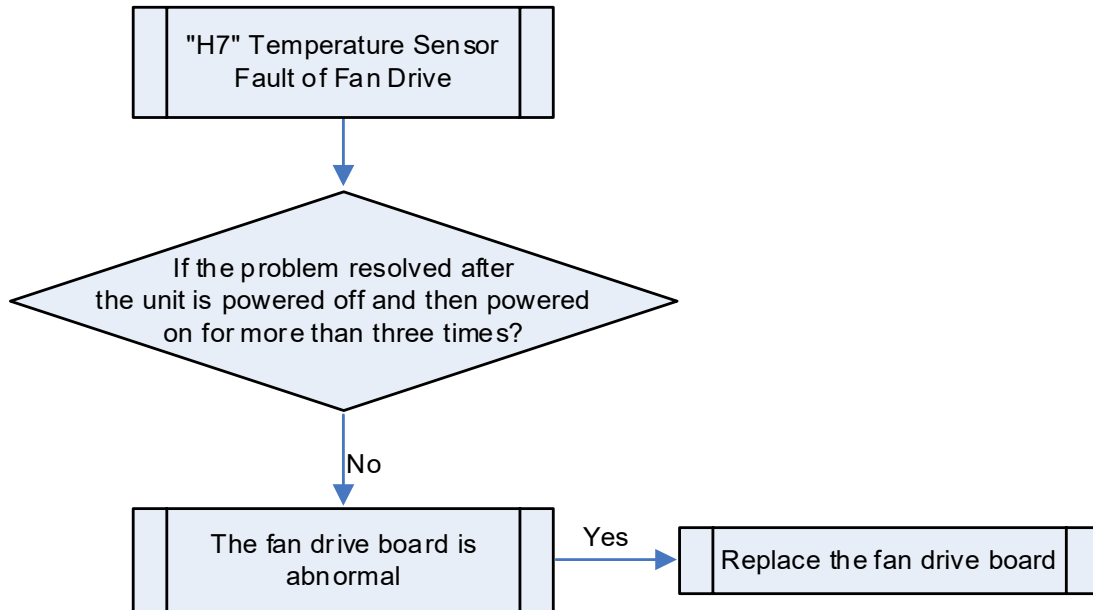

2.94 "H8" IPM Over Temperature Protection for Fan Drive



Fault display: main board of outdoor unit displays

Fault diagnosis:

If the fault code displayed on the 2-digit digital LED of the outdoor unit's main control board is H8, it indicates the IPM over temperature protection for the fan drive.

Possible causes:

- The IPM module is not covered, or unevenly covered by thermal grease, or covered by dried thermal grease;

- The IPM module's screws are not tightened;

- The fan drive board operates improperly.

Troubleshooting:

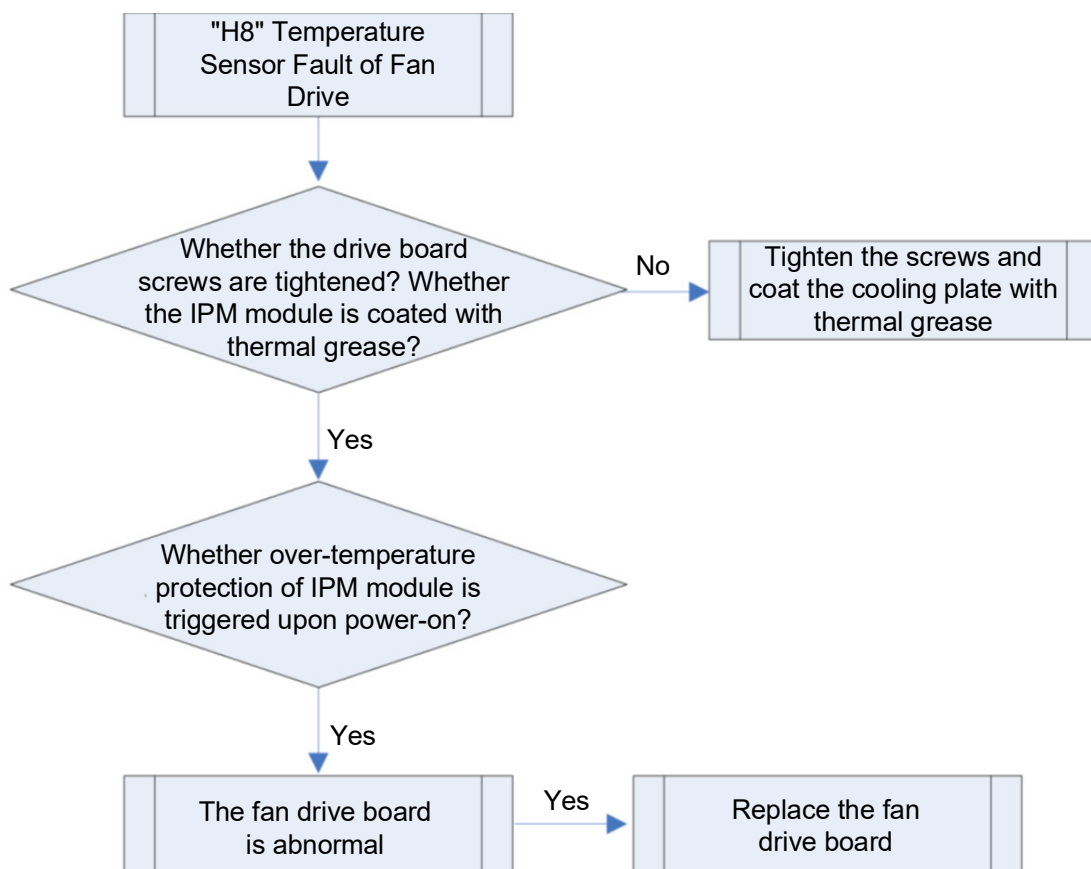

2.95 "H9" Loss of Synchronization Protection for Inverter Fan



Fault display: main board of outdoor unit displays

Fault diagnosis:

If the fault code displayed on the 2-digit digital LED of the outdoor unit's main control board is H9, it indicates the loss of synchronization protection for the inverter fan.

Possible causes:

- Poor contact of fan's UVW cables;
- The fan is damaged;
- The blades are stuck (the blades are blocked or the motor shaft gets rusty);
- The fan drive board operates improperly.

Troubleshooting:

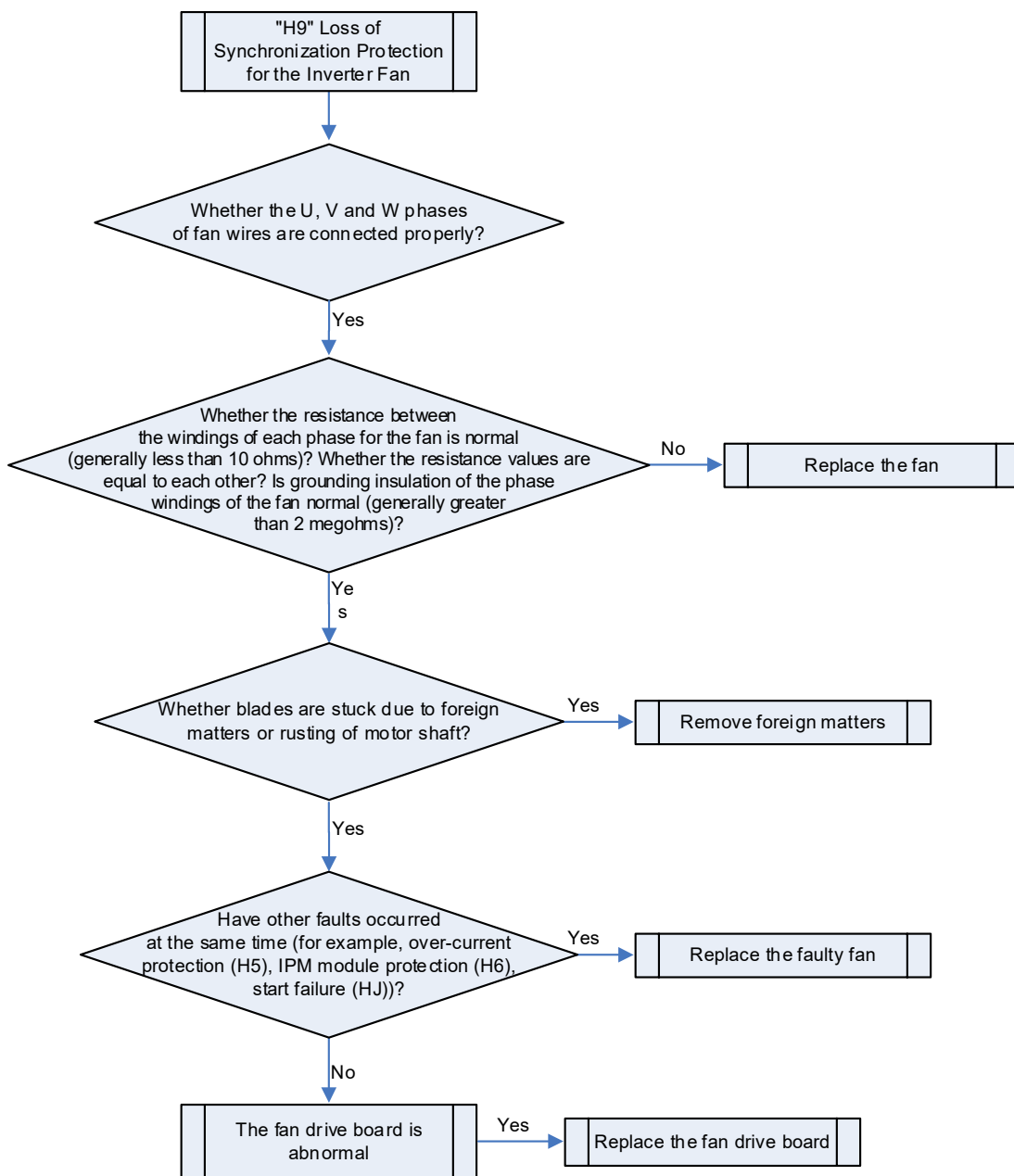

2.96 "HC" Current Detection Circuit Fault of Fan Drive



Fault display: main board of outdoor unit displays

Fault diagnosis:

If the fault code displayed on the 2-digit digital LED of the outdoor unit's main control board is HC, it indicates the current detection circuit fault of fan drive.

Possible causes:

- The fan drive board operates improperly.

Troubleshooting:

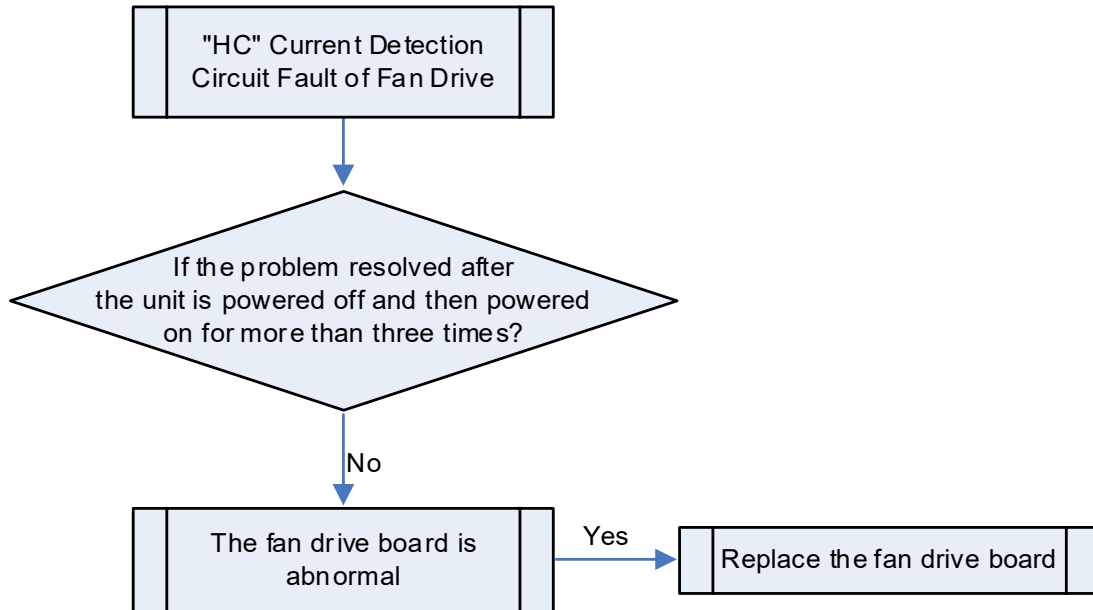

2.97 "HH" Over Voltage Protection for DC Bus of Fan Drive



Fault display: main board of outdoor unit displays

Fault diagnosis:

If the fault code displayed on the 2-digit digital LED of the outdoor unit's main control board is HH, it indicates the over voltage protection for the DC bus of fan drive.

Possible causes:

- The unit's input power cable has a voltage exceeding 460V;
- The fan drive board operates improperly.

Troubleshooting:

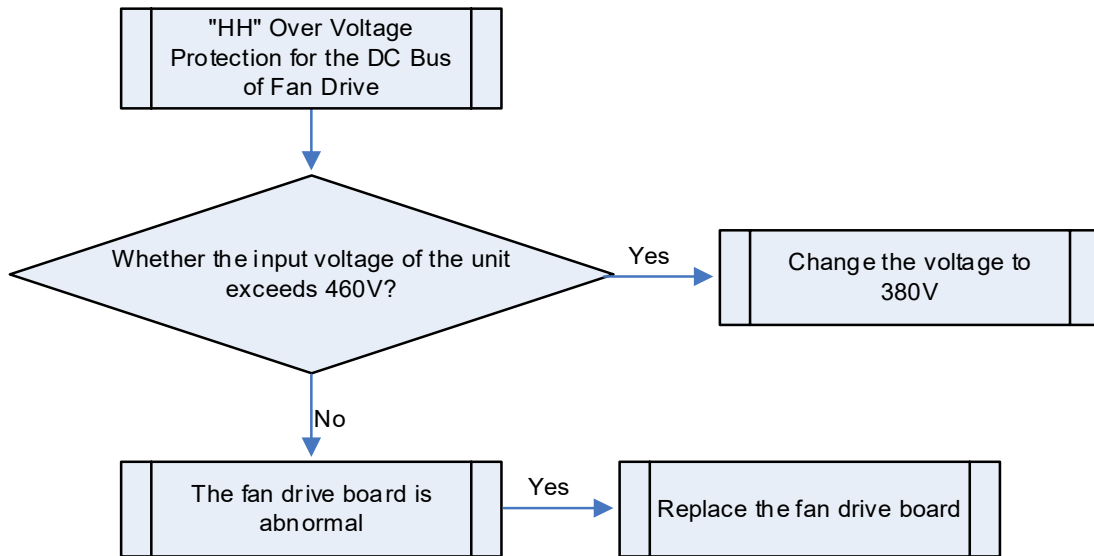

2.98 "HL" Under Voltage Protection for DC Bus of Fan Drive

Fault display: main board of outdoor unit displays



Fault diagnosis:

If the fault code displayed on the 2-digit digital LED of the outdoor unit's main control board is HL, it indicates the under voltage protection for the DC bus of fan drive.

Possible causes:

- The unit's input power cable has a voltage below 320 V;
- The fan drive board operates improperly.

Troubleshooting:

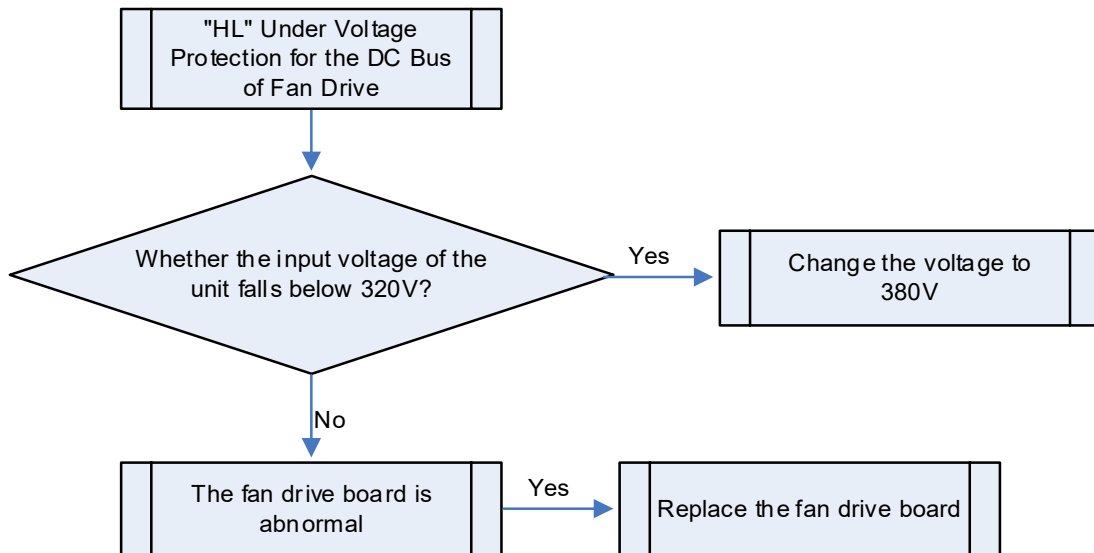

2.99 "HJ" Inverter Fan Startup Failure



Fault display: main board of outdoor unit displays

Fault diagnosis:

If the fault code displayed on the 2-digit digital LED of the outdoor unit's main control board is HJ, it indicates the inverter fan startup failure.

Possible causes:

- Poor contact of fan's UVW cables;
- The fan is damaged;
- The blades are stuck (the blades are blocked or the motor shaft gets rusty);
- The fan drive board operates improperly.

Troubleshooting:

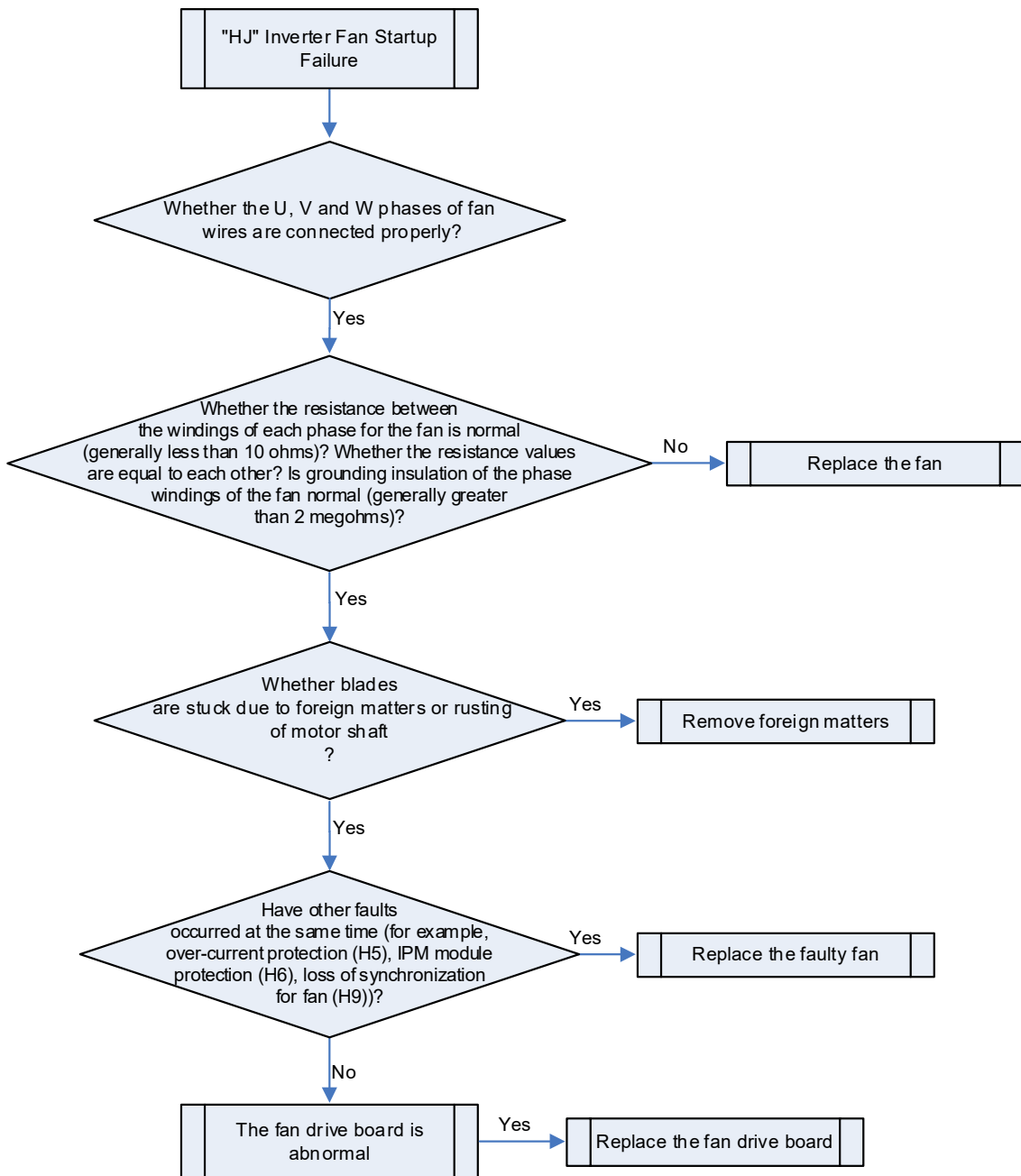

2.100 "J0" Protection for Other Modules

Fault display: main board of outdoor unit displays  while the indoor unit and receiver of indoor unit do not.

Applicable models: GMV6, GMV5, GMV5S, TOPS, GMV water Series

Fault diagnosis:

In a multi-module system, the fault of any module will cause any other properly operating modules to display the fault code. It indicates that some other module has a fault, thereby causing the shutdown of the unit to ensure safe operation.

Possible causes:

- Other modules have faults, thereby causing the unit to stop operation.

Troubleshooting:

Troubleshoot other modules.

2.101 "J1" Compressor 1 Over-current Protection

Fault display: main board of outdoor unit, wired controller of indoor unit and receiver of indoor unit display 

Fault diagnosis:

When the operating current of the compressor detected by the current sensor or circuit exceeds the limit, the unit will stop working.

Possible causes:

- The unit's parameters are abnormal;
- The drive module is abnormal;
- The compressor is abnormal.

Troubleshooting:

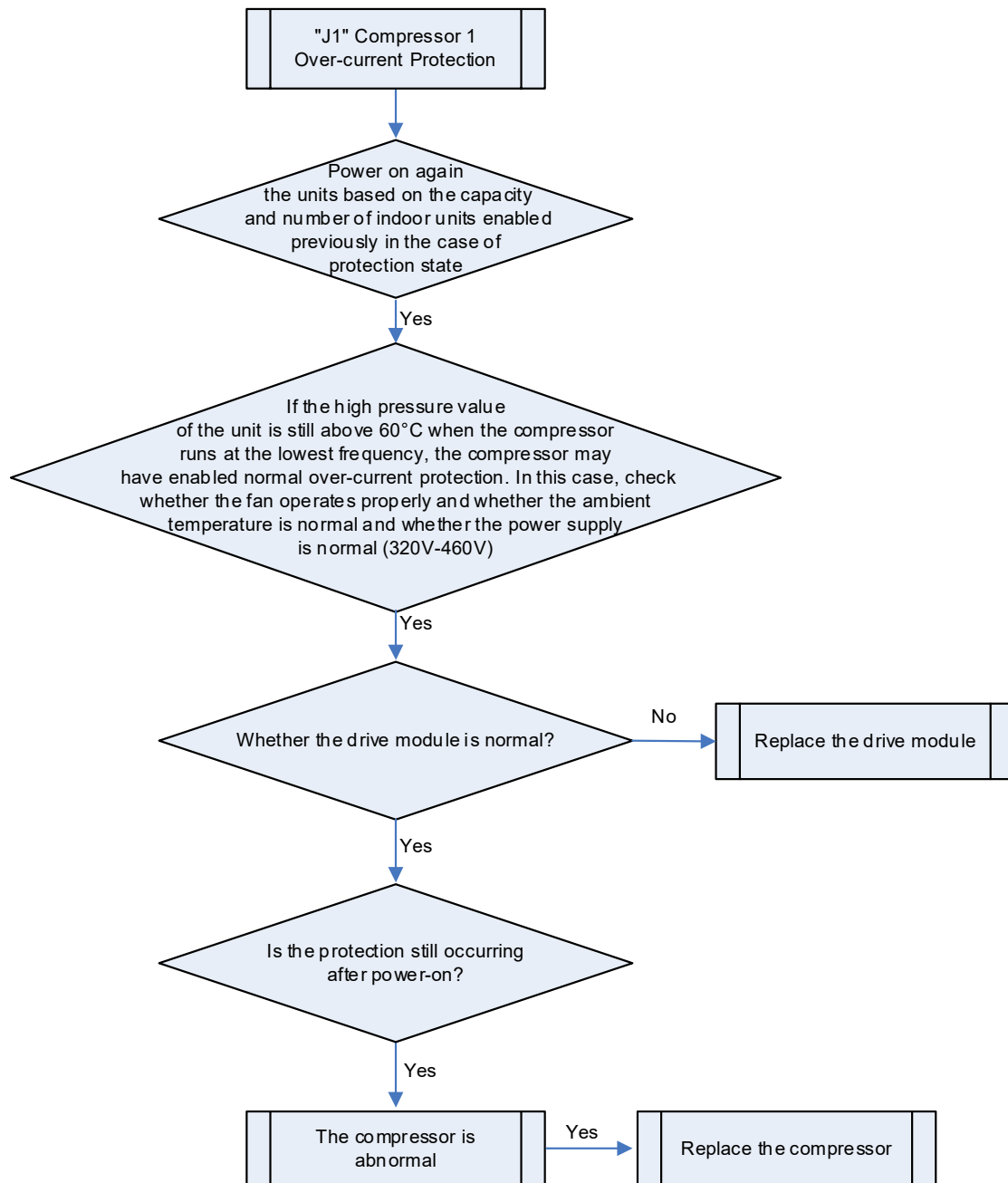

2.102 "J2" Compressor 2 Over-current Protection

Fault display: main board of outdoor unit, wired controller of indoor unit and receiver of indoor unit



Fault diagnosis:

When the operating current of the compressor detected by the current sensor or circuit exceeds the limit, the unit will stop working.

Possible causes:

- The unit's parameters are abnormal;
- The drive module is abnormal;
- The compressor is abnormal.

Troubleshooting:

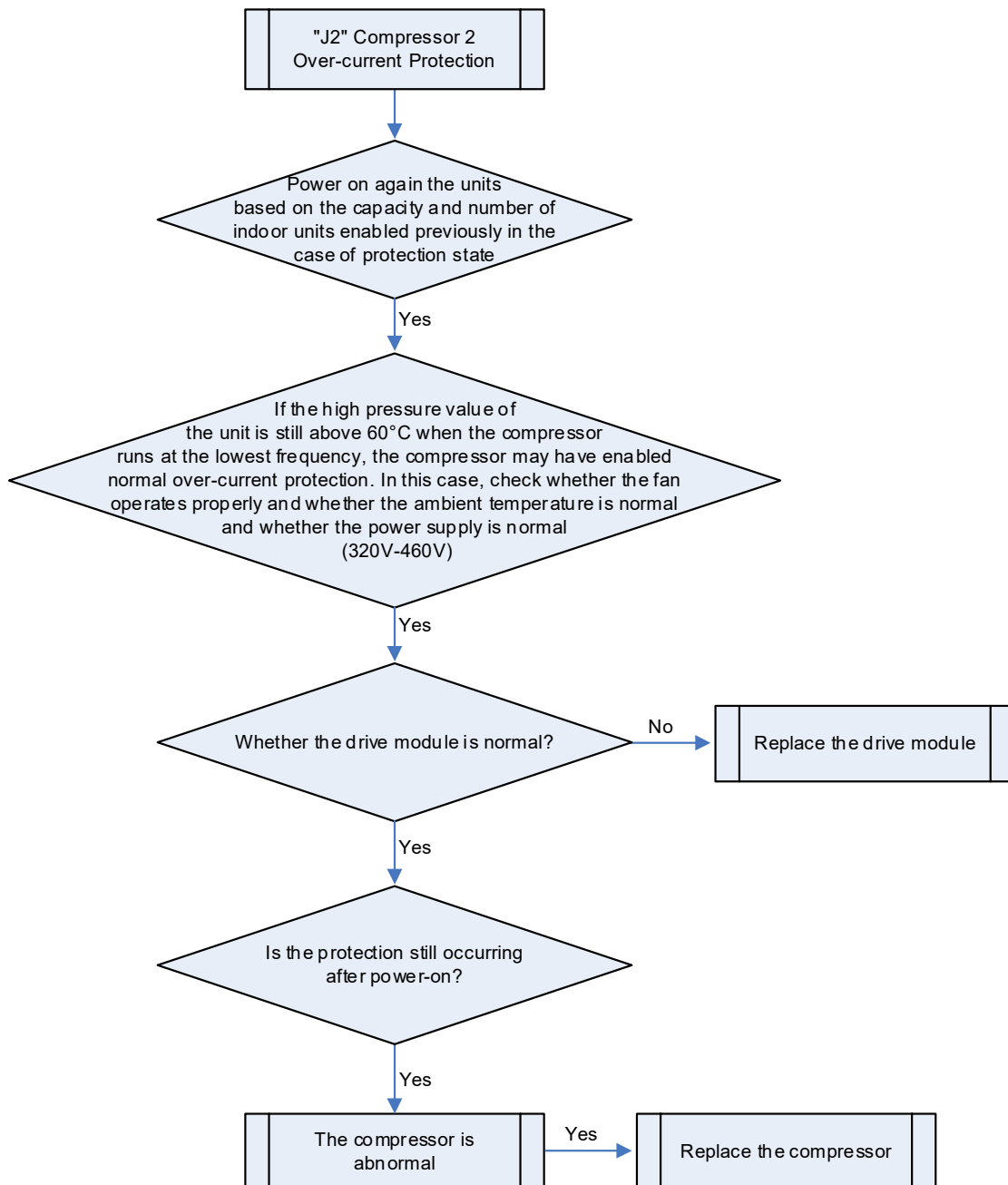

2.103 "J3" Compressor 3 Over-current Protection

Fault display: main board of outdoor unit, wired controller of indoor unit and receiver of indoor unit



Fault diagnosis:

When the operating current of the compressor detected by the current sensor or circuit exceeds the limit, the unit will stop working.

Possible causes:

- The unit's parameters are abnormal;
- The drive module is abnormal;
- The compressor is abnormal.

Troubleshooting:

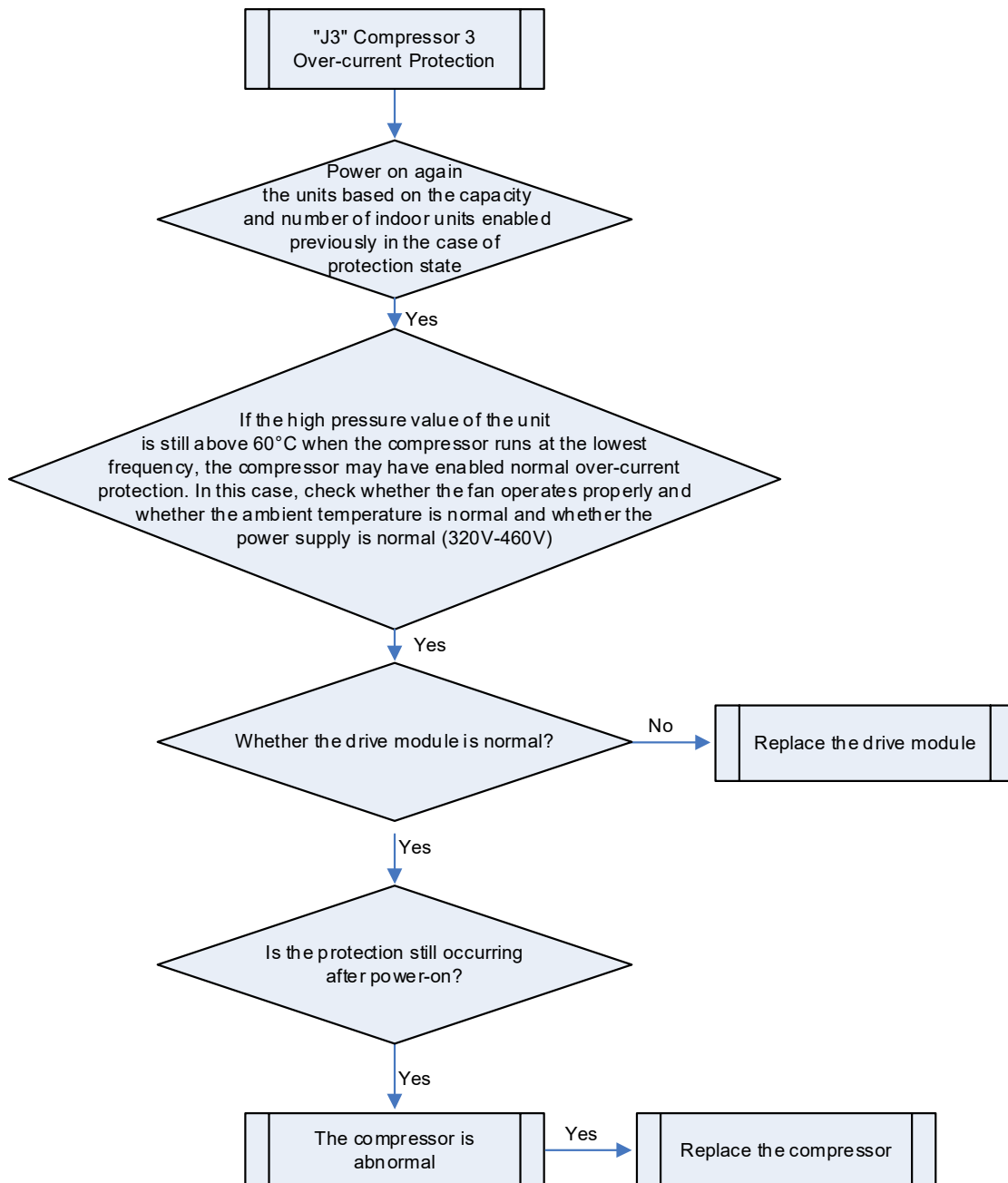

2.104 "J4" Compressor 4 Over-current Protection

Fault display: main board of outdoor unit, wired controller of indoor unit and receiver of indoor unit



Fault diagnosis:

When the operating current of the compressor detected by the current sensor or circuit exceeds the limit, the unit will stop working.

Possible causes:

- The unit's parameters are abnormal;
- The drive module is abnormal;
- The compressor is abnormal.

Troubleshooting:

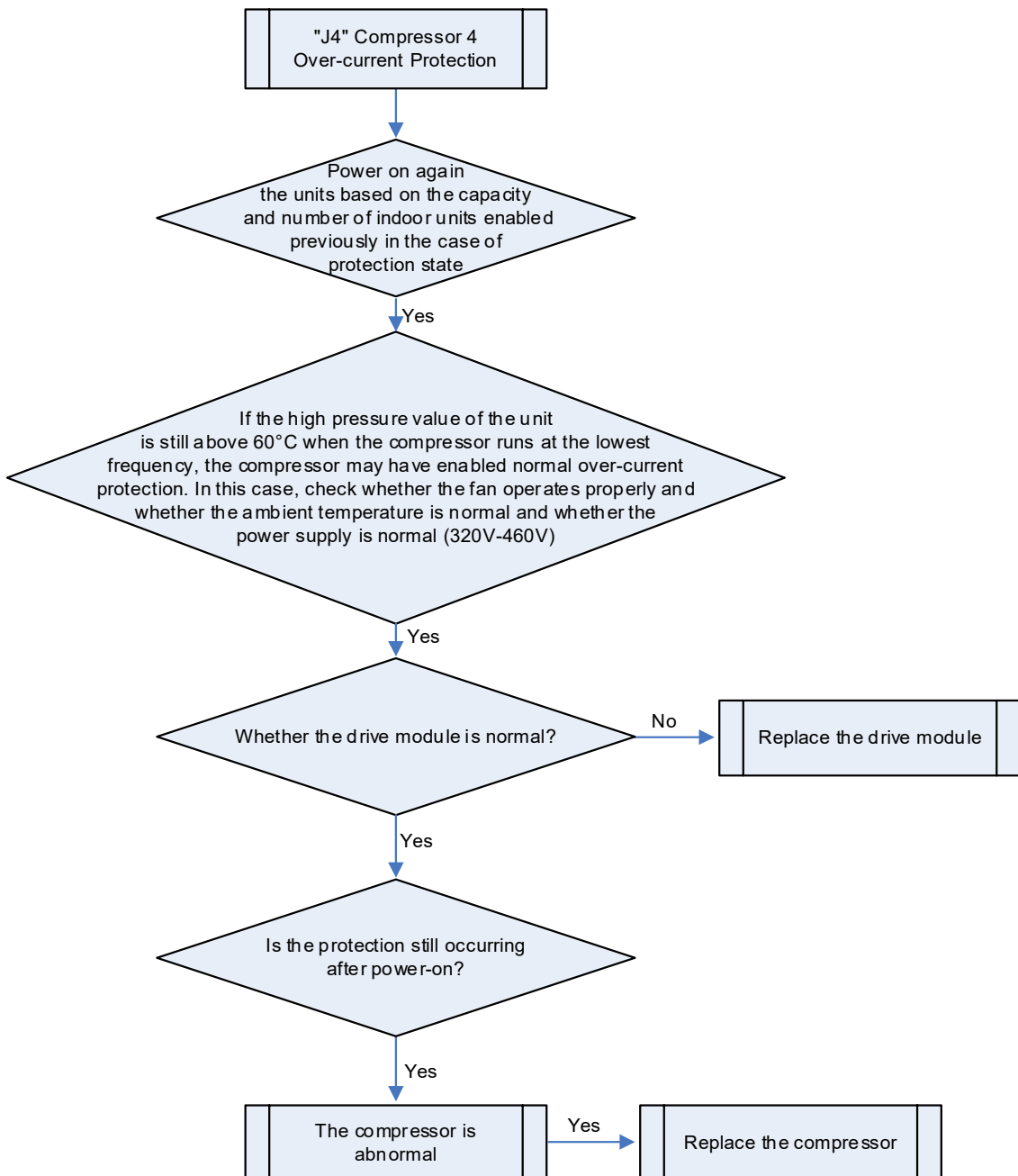

2.105 "J5" Compressor 5 Over-current Protection

Fault display: main board of outdoor unit, wired controller of indoor unit and receiver of indoor unit



Fault diagnosis:

When the operating current of the compressor detected by the current sensor or circuit exceeds the limit, the unit will stop working.

Possible causes:

- The unit's parameters are abnormal;
- The drive module is abnormal;
- The compressor is abnormal.

Troubleshooting:

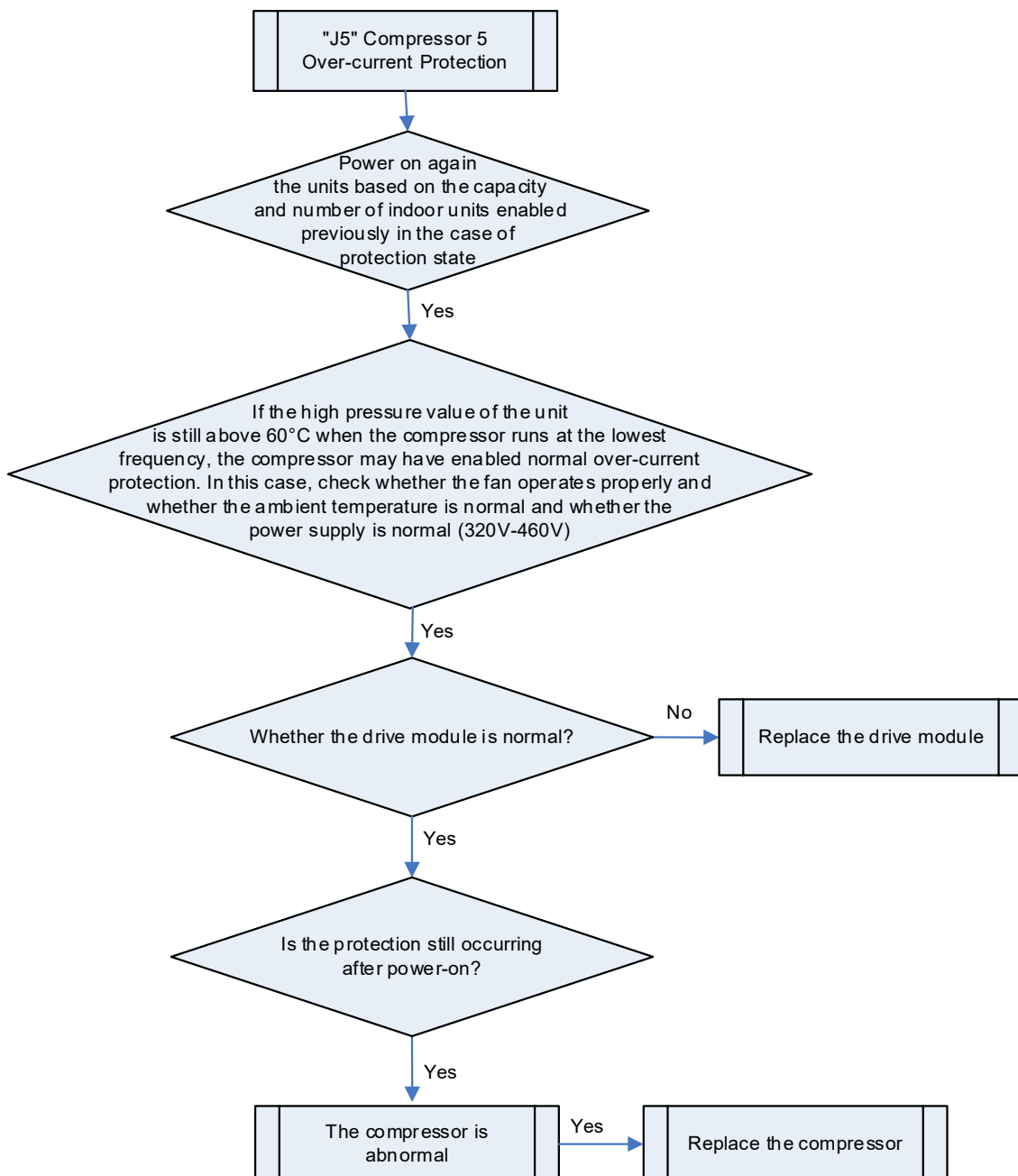

2.106 "J6" Compressor 6 Over-current Protection

Fault display: main board of outdoor unit, wired controller of indoor unit and receiver of indoor unit



Fault diagnosis:

When the operating current of the compressor detected by the current sensor or circuit exceeds the limit, the unit will stop working.

Possible causes:

- The unit's parameters are abnormal;
- The drive module is abnormal;
- The compressor is abnormal.

Troubleshooting:

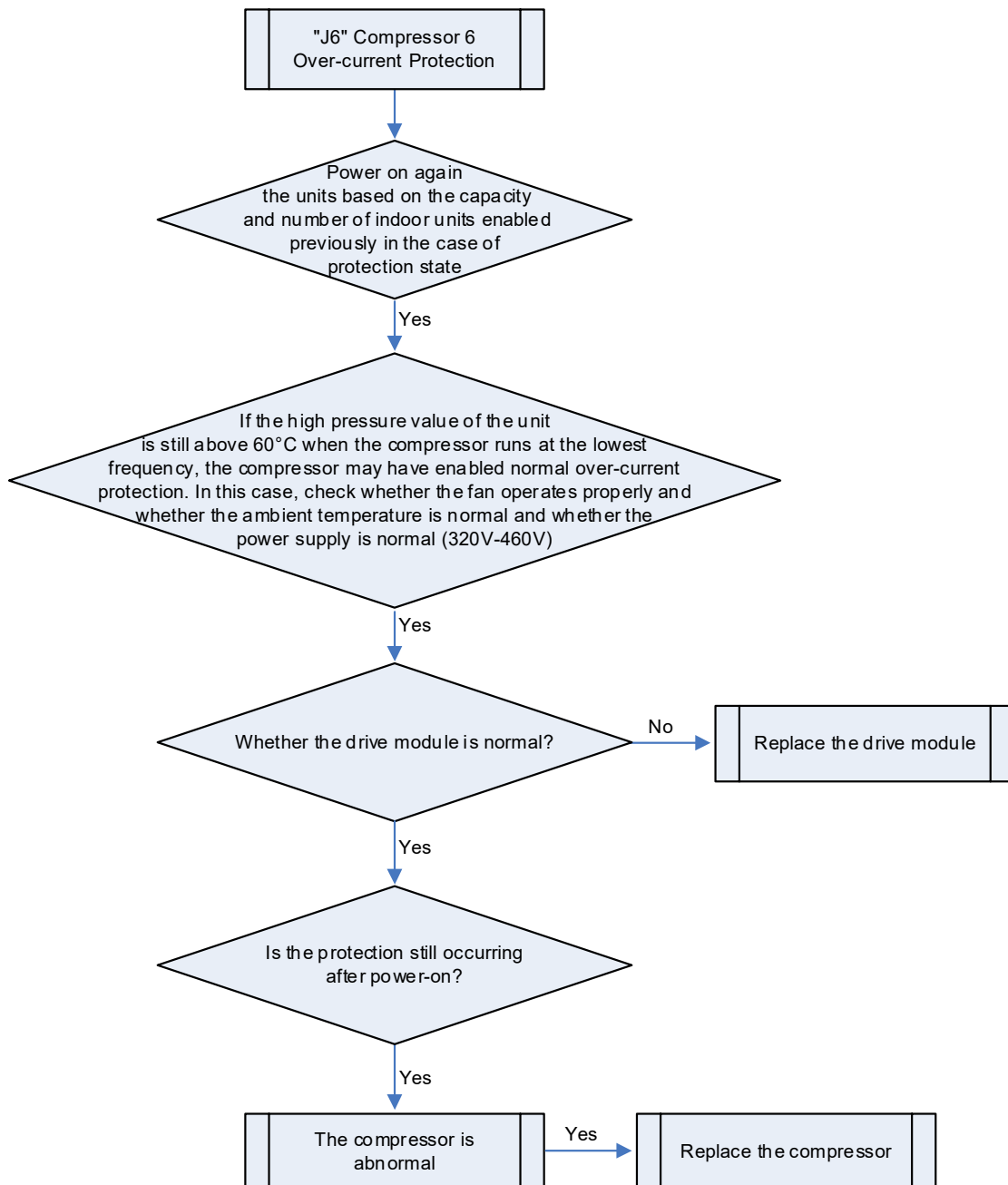

2.107 "J7" Four-way Valve Air Backflow Protection

Fault display: main board of outdoor unit, wired controller of indoor unit and receiver of indoor unit

display 

Fault diagnosis:

When the difference between the system high pressure and low pressure during operation detected by the pressure sensor is less than 0.1 MPa, the unit will stop running to ensure safe operation.

Possible causes:

- The coil or connecting wire is abnormal;
- The main board is abnormal;
- The four-way valve is abnormal.

Troubleshooting:

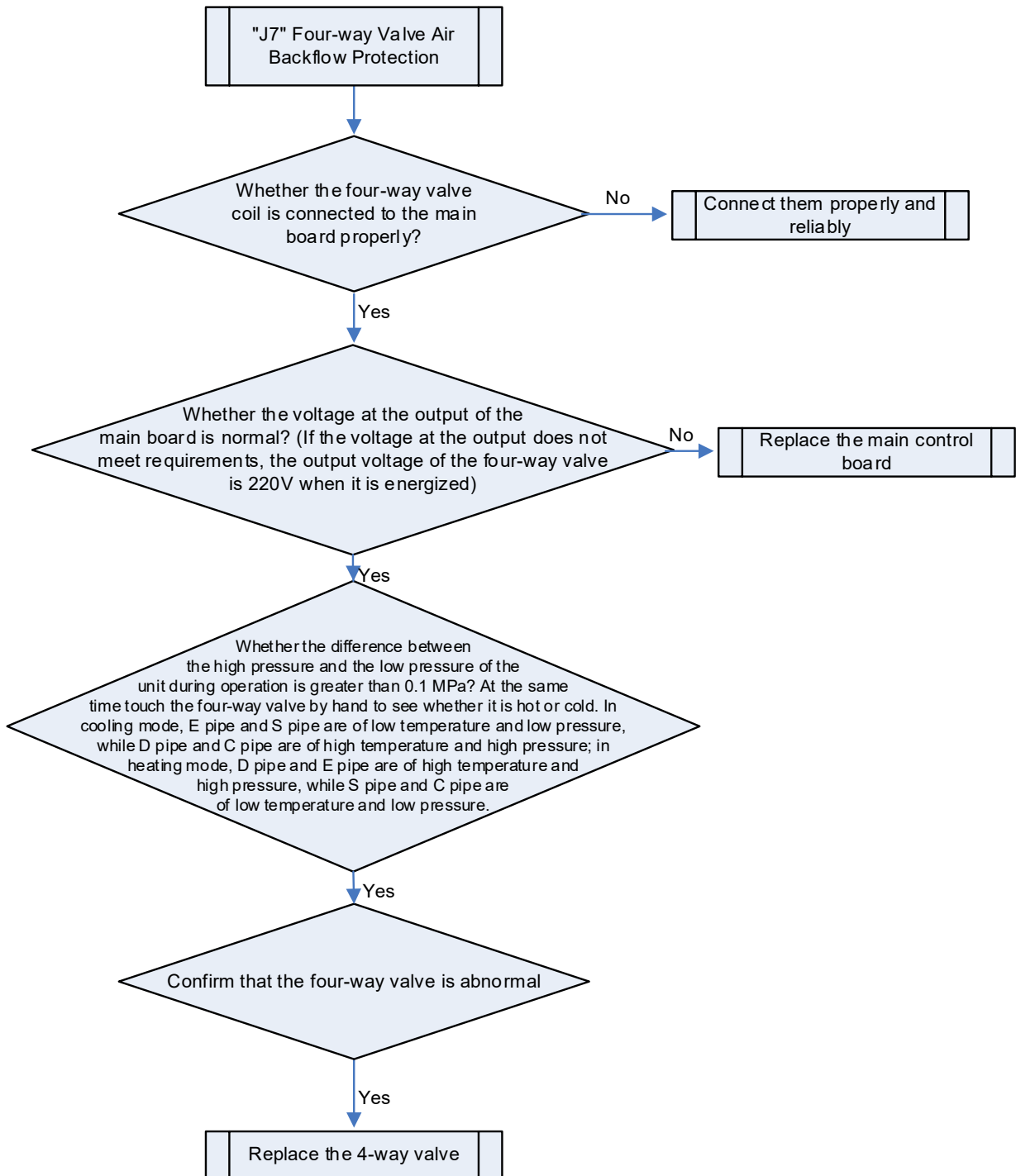

2.108 "J8" High Pressure Ratio Protection

Fault display: main board of outdoor unit, wired controller of indoor unit and receiver of indoor unit



Fault diagnosis:

When the ratio between the system high pressure and the low pressure during operation detected by the pressure sensor exceeds 8, the unit will stop running to ensure safe operation.

Possible causes:

- The pressure sensor is abnormal;
- The ambient temperature where the unit operates exceeds the limit.

Troubleshooting:

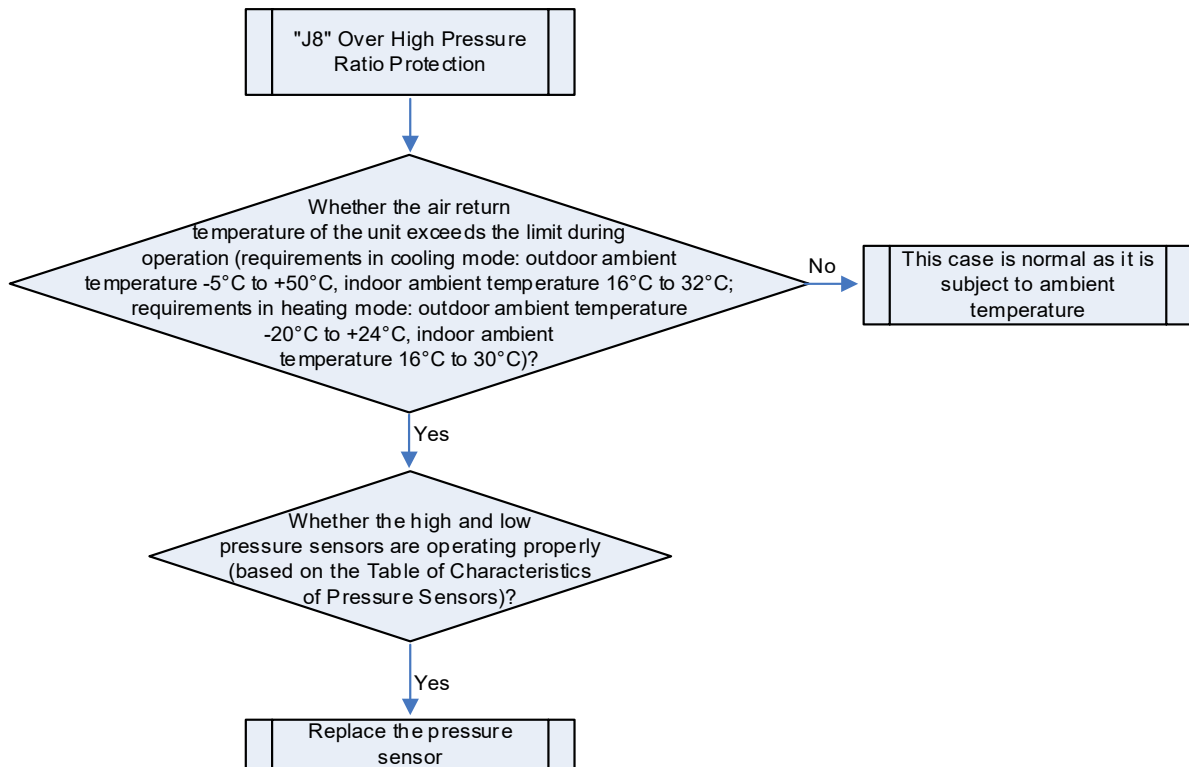

2.109 "J9" Low Pressure Ratio Protection

Fault display: main board of outdoor unit, wired controller of indoor unit and receiver of indoor unit

display 

Fault diagnosis:

When the ratio between the system high pressure and the low pressure during operation detected by the pressure sensor is smaller than 1.8, the unit will stop running to ensure safe operation.

Possible causes:

- The pressure sensor is abnormal;
- The ambient temperature where the unit operates exceeds the limit.

Troubleshooting:

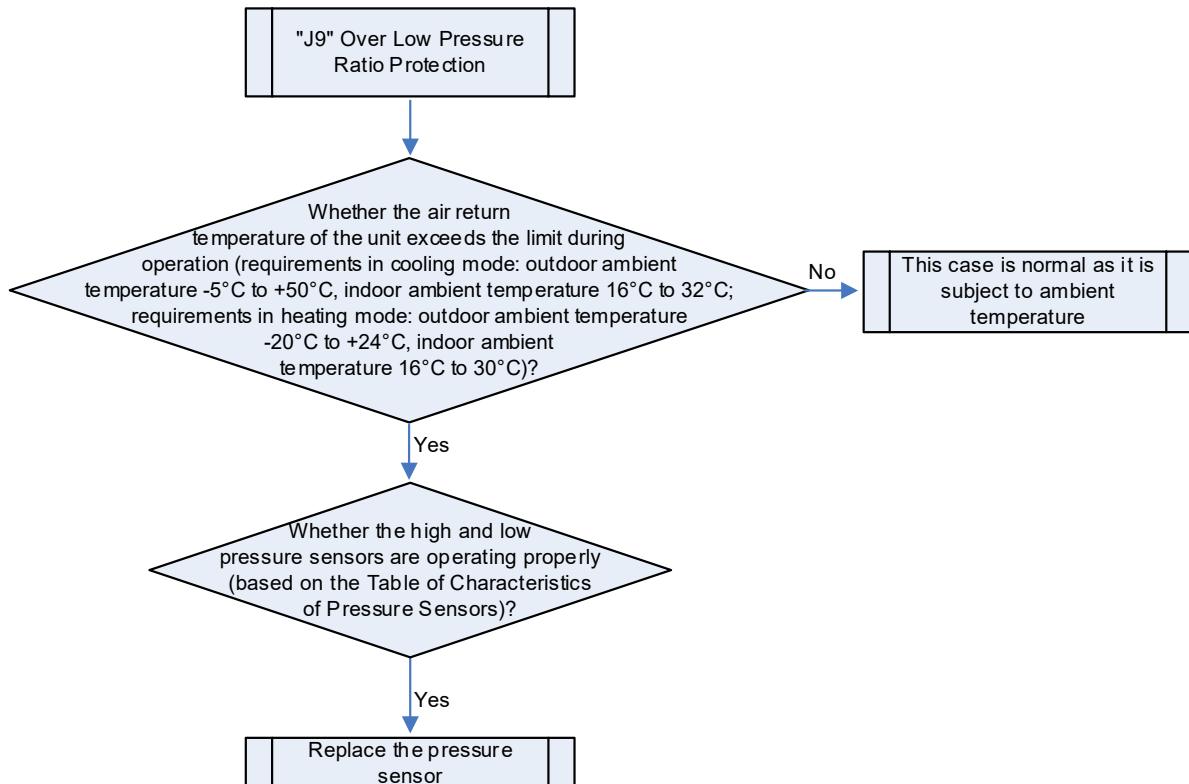

2.110 "L0" Indoor Unit Fault (Unified)

Fault display: wired controller of indoor unit displays



Applicable models: all indoor units

Possible causes:

- The indoor unit is faulty.

Troubleshooting:

When multiple indoor units are installed in the same place, you can use the function of "indoor unit engineering SN query and fault indoor unit identification" to fast locate the faulty indoor unit or the corresponding indoor unit controlled by a wired controller. The detailed operations are as follows:

"C01" indoor unit engineering SN and fault query:



Long press FUNCTION for five seconds when the conditioner is on or off to view parameters.



Press "MODE" to show parameter code C01.



Press "MODE" or "MODE" to switch between indoor units.



Press MODE to view indoor units' engineering numbers and failures. The engineering number is shown in the timer area, while the failure code is shown in the temperature area (Note 1). Meanwhile, the corresponding failing indoor unit's buzzer buzzes.



Press ENTER/CANCEL (Note 2) to quit the interface of the indoor unit's engineering number and failure and return to the previous interface.



Press ENTER/CANCEL or ON/OFF to quit the parameter interface.

NOTES!

- ① If the enquired IDU is normal, no fault code will be displayed in the temperature area; if the unit indoor has multiple faults, fault codes will be displayed in the temperature area at an interval of 3 seconds.
- ② Press the "ON/OFF" button on the interface of IDU project number and fault enquiry to exist the parameter enquiry interface.

2.111 "L1" Indoor Fan Protection



Fault display: wired controller of indoor unit and receiver of indoor unit display

Applicable models: all indoor units

Fault diagnosis:

Check whether the indoor unit rotates slowly or stops or whether there exists external fan protection signal. If yes, it indicates the indoor fan protection.

Possible causes:

- The motor stops or is stuck
- The main board of indoor unit operates improperly

Troubleshooting:

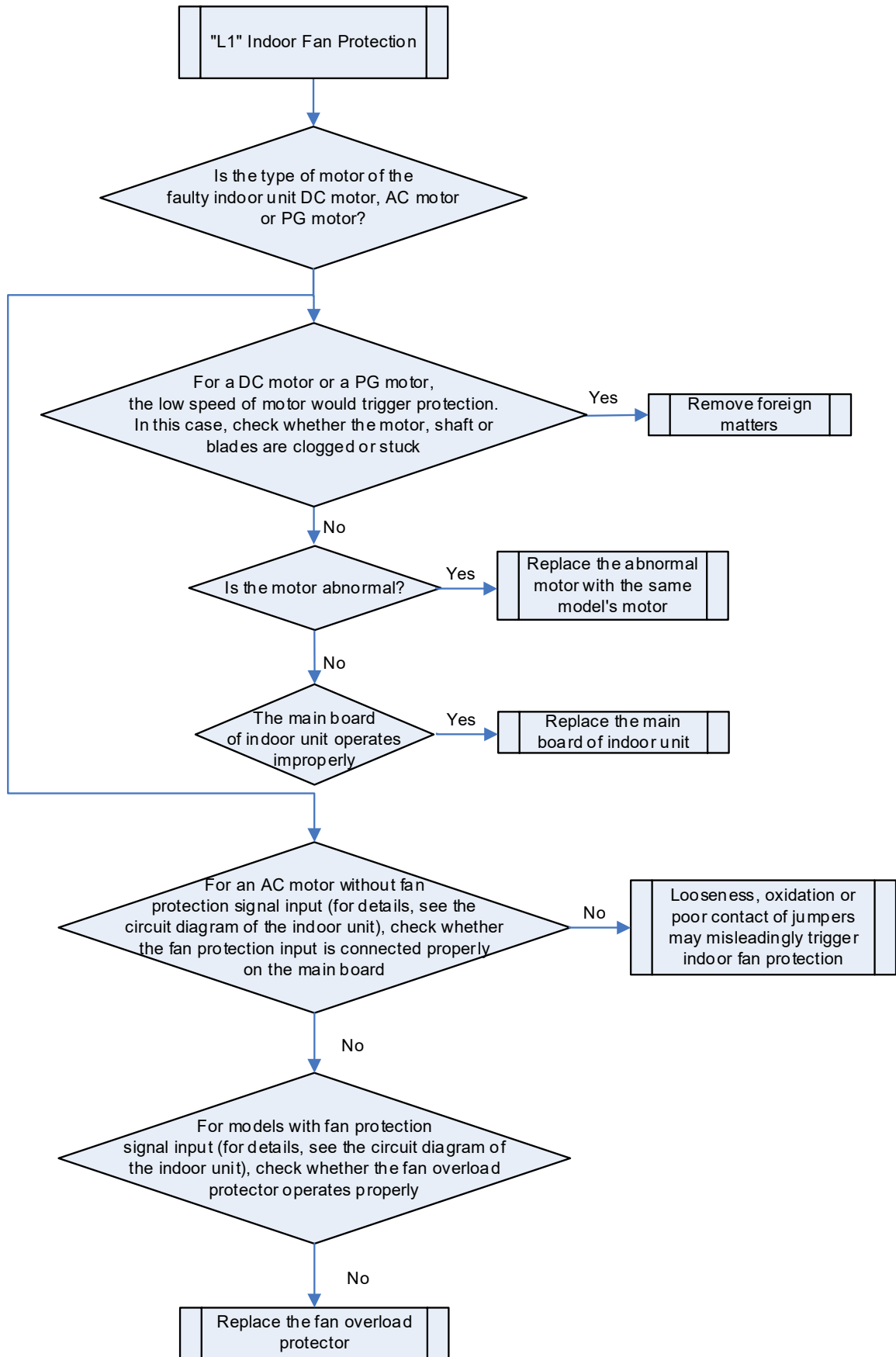

2.112 "L2" E-heater Protection (Reserved Code, Not Yet Applied)

2.113 "L3" Overflow Protection



Fault display: wired controller of indoor unit and receiver of indoor unit display

Applicable models: all indoor units

Fault diagnosis:

When the water level is too high, the float switch of indoor unit will be triggered for overflow protection.

Possible causes:

- The indoor unit is installed improperly;
- The drain pump is damaged;
- The float switch operates improperly;
- The main board of indoor unit operates improperly.

Troubleshooting:

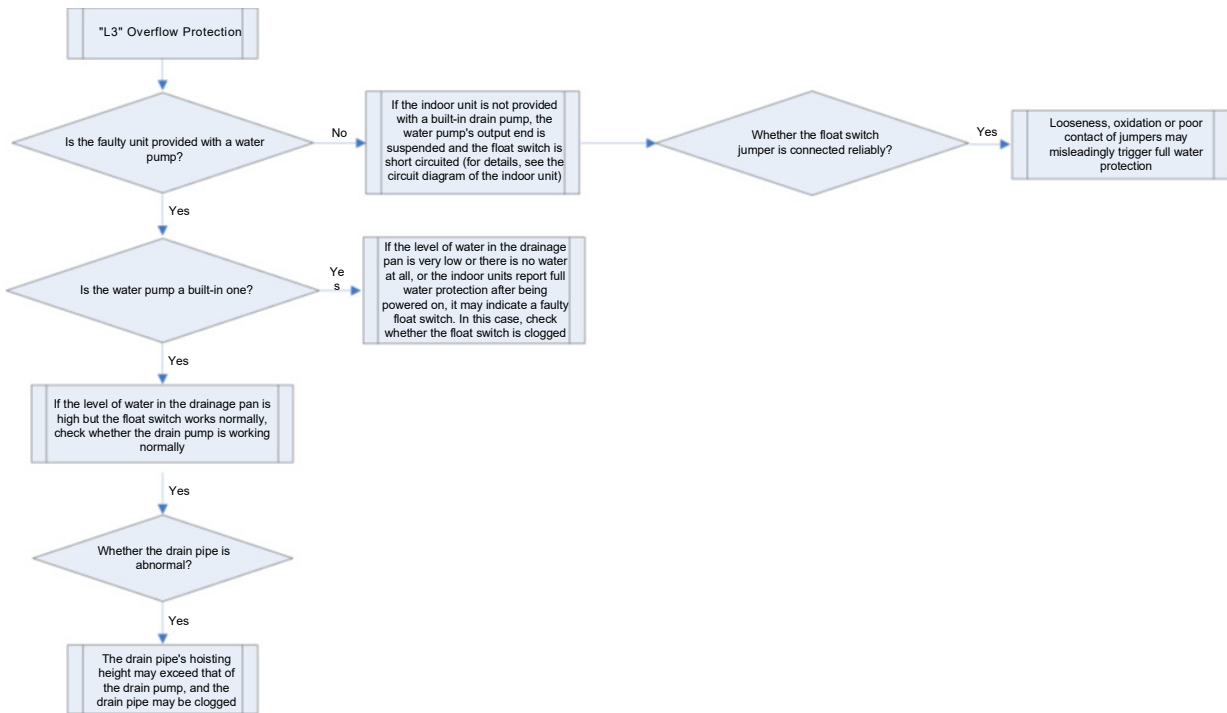

2.114 "L4" Supply Power Over-current Protection



Fault display: wired controller of indoor unit and receiver of indoor unit display

Applicable models: all indoor units

Fault diagnosis:

When the current supplied to the wired controller by the indoor unit is too large, the fault is generated.

Possible causes:

- The wires of the wired controller are short circuited;
- The main board of indoor unit operates improperly;
- The main board of the wired controller is abnormal.

Troubleshooting:

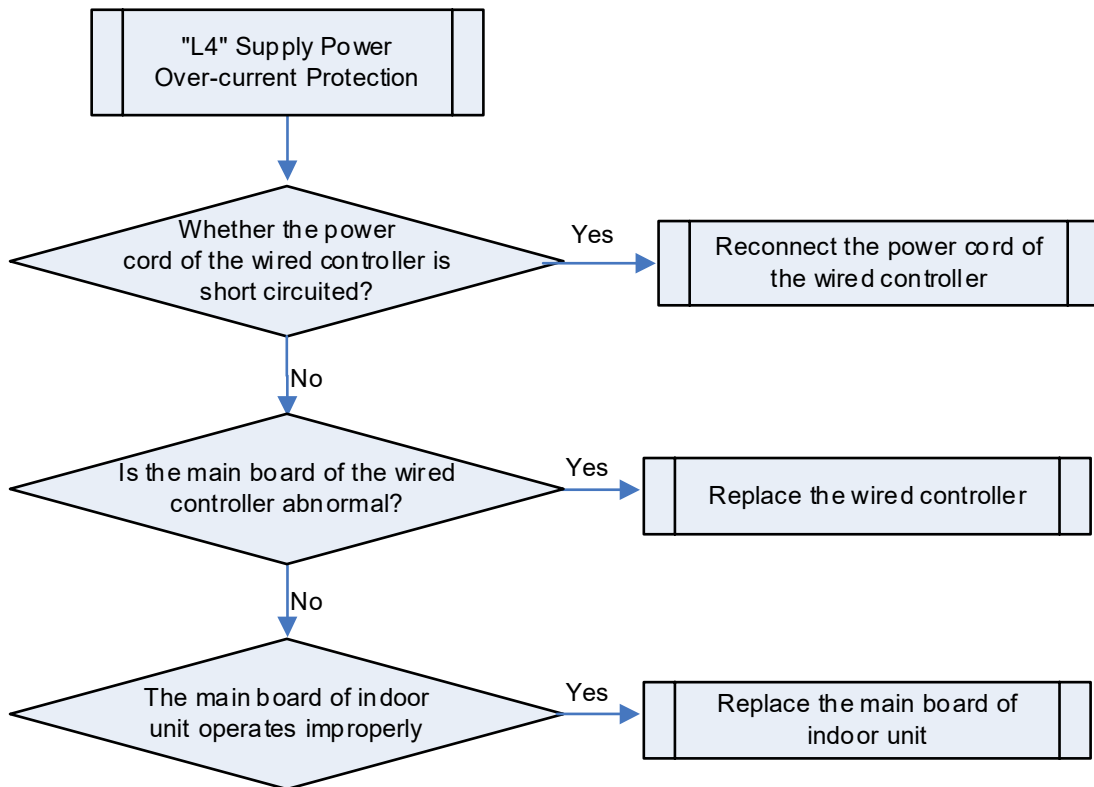

2.115 "L5" Antifreeze Protection



Fault display: wired controller of indoor unit and receiver of indoor unit display

Applicable models: all indoor units

Fault diagnosis:

When the pipe temperature of the indoor unit is too low, the unit will trigger antifreeze protection to prevent the evaporator from freezing.

Possible causes:

- The indoor filter and evaporator are dirty;
- The indoor motor is stuck;
- Insufficient refrigerant in the unit;
- The ambient temperature where the indoor unit and outdoor unit operate is too low.

Troubleshooting:

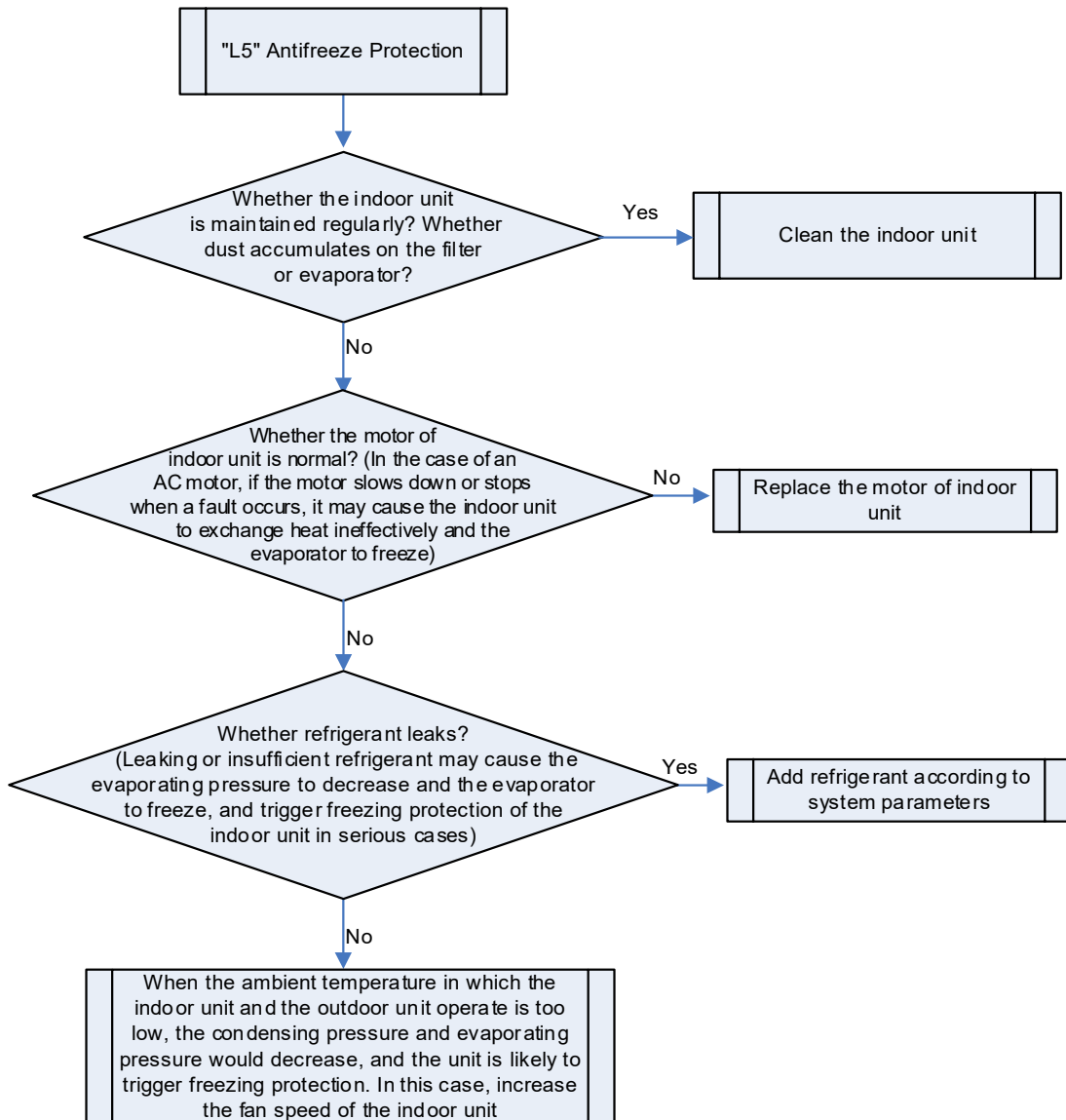

2.116 "L6" Mode Conflict (Reserved)

2.117 "L7" No Master Indoor Unit

Fault display: wired controller of indoor unit and receiver of indoor unit display



Applicable models: all indoor units

Fault diagnosis:

The unit triggers the "no master indoor unit" fault when no master indoor unit exists in the system.

Possible causes:

- The master indoor unit is disconnected;
- The main board of the master indoor unit is replaced;
- The main board of the master indoor unit is faulty.

Troubleshooting:

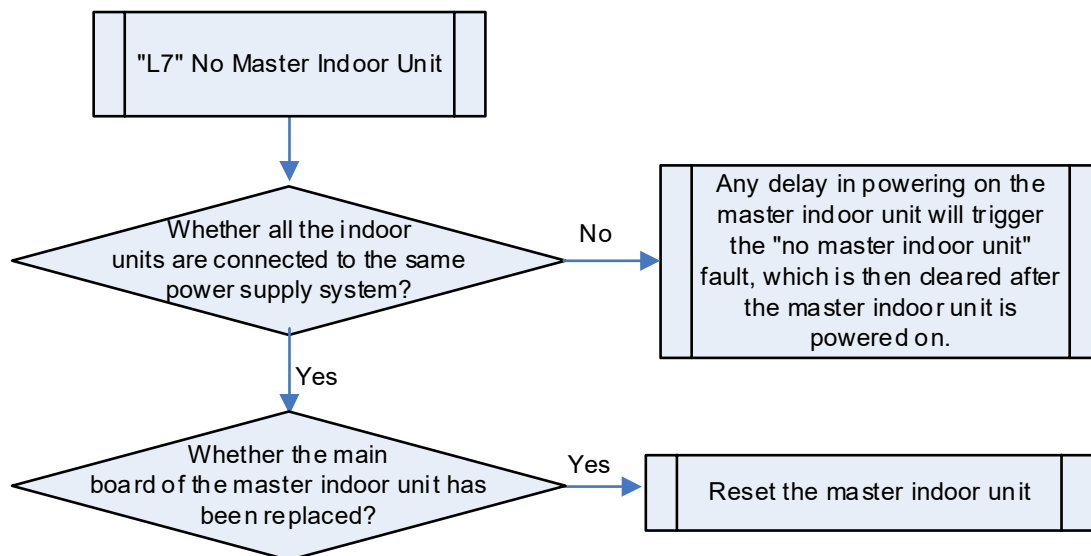

2.118 "L9" Inconsistent Number of Indoor Units Under Integrated Control



Fault display: wired controller of indoor unit and receiver of indoor unit display

Applicable models: all indoor units

Fault diagnosis:

When more than 16 indoor units are connected to the wired controller or the number of indoor units connected to the wired controller is not the same as what is configured under integrated control, the fault is generated.

Possible causes:

- More than 16 indoor units are connected to one wired controller;
- The number of indoor units connected to the wired controller is not the same as what is configured under integrated control.

Troubleshooting:

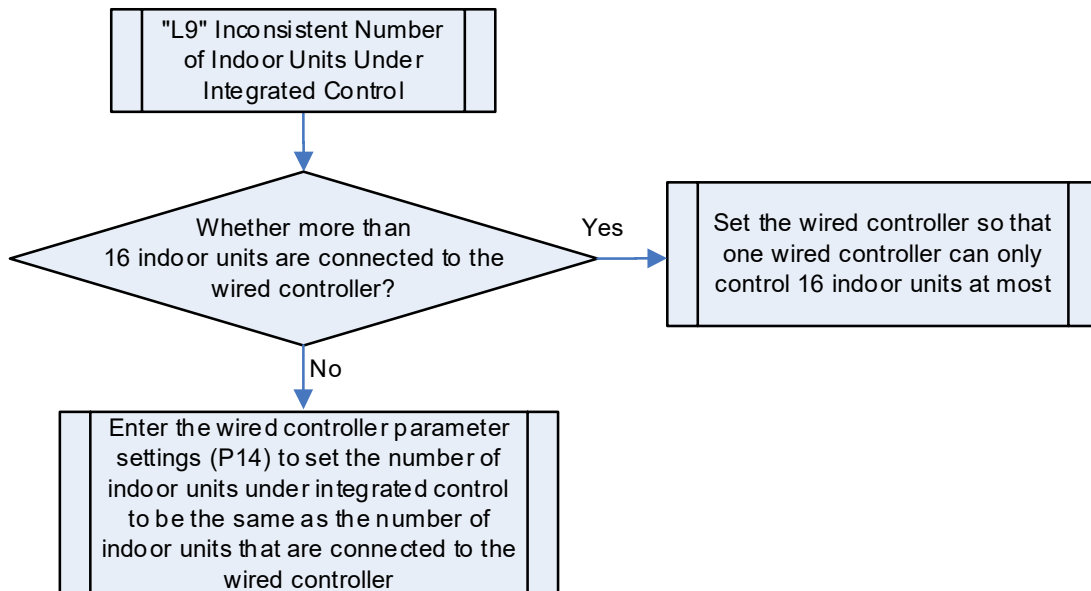

2.119 "LA" Inconsistent Series of Indoor Units Under Integrated Control



Fault display: wired controller of indoor unit and receiver of indoor unit display

Applicable models: all indoor units

Fault diagnosis:

When the wired controller detects that the multiple indoor units connected to it belong to different series, the fault is generated.

Possible causes:

- The multiple indoor units connected to the wired controller belong to different series.

Troubleshooting:

Make sure that the multiple indoor units connected to the wired controller belong to the same series.

2.120 "LH" Poor Air Quality Alarm (Reserved Code, Not Yet Applied)

2.121 "LC" Unmatched Models of Indoor and Outdoor Units

Fault display: wired controller of indoor unit and receiver of indoor unit display



Applicable models: some indoor units

Fault diagnosis:

The unit triggers the fault of "unmatched indoor and outdoor units" when it fails to recognize some indoor units or equipment.

Possible causes:

- The indoor unit is incompatible with the outdoor unit.

Troubleshooting:

The unit triggers the fault when it is connected to indoor units or equipment that it cannot recognize, such as floor heating in a modular DC inverter VRF system. In this case, to troubleshoot this fault, you can remove the involved indoor units or change the outdoor unit to make it match the indoor units.

2.122 "LL" Water Flow Switch Error

Error display: wired controller of hydro box will display



Applicable model: hydro box

Error judgment condition and method:

Detect if the protection signal of water flow switch is triggered. After turning on the water pump, waterflow switch protection signal is detected in 15 consecutive seconds, then report alarm.

Possible reasons:

- Poor contact between limit switch and terminal in main board interface
- Water return of generator is not smooth or lacking water
- Water flow switch is abnormal
- Detecting circuit is abnormal

Troubleshooting:

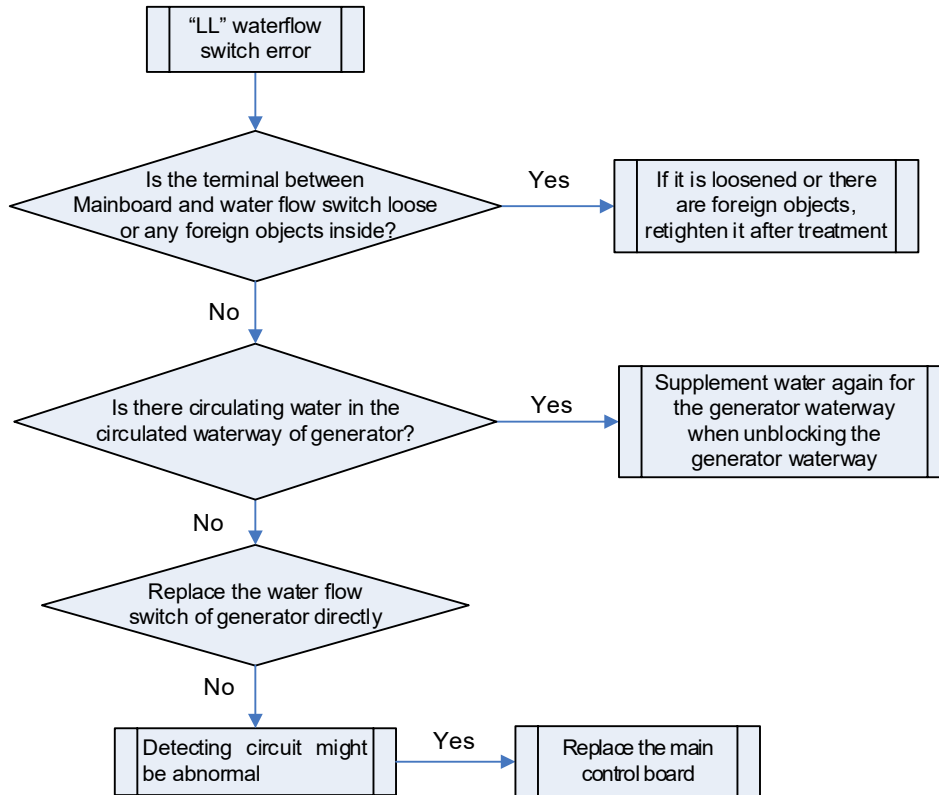

2.123 “LF” Shunt Valve Setting Error

Error display: wired controller of hydro box will display

LF

Applicable model: hydro box

Error judgment condition and method:

When setting the corresponding relationship for the floor heating shunt valve and IDU, the generator shall detect and judge the project code of IDU to see if the nonexistent project code is set or shunt valve setting error alarm occurs if the same shunt valve is matching with several IDUs (project code)

Possible reasons

- IDU linked with floor heating is offline
- Project code conflict or IP conflict

Troubleshooting

Step 1: check if the IDU corresponding to the shunt valve is offline, if yes, the IDU is deemed offline;

Step 2: check if the project code or IP is conflict, if yes, adjust the relationship between shunt valve and IDU again, allow several shunt valves to match with the same IDU (project code), but never allow the same shunt valve to match with several IDUs (project code).

2.124 “LU” Inconsistent IDU Branch Connecting to the Wired Controller Which Controls Multiple Indoor Units of Heat Recovery System

Error display: wired controller will display 

Applicable model: wired controller connecting to several IDUs

Error judgment condition and method:

When the controller which controls multiple indoor units is connected to several indoor units, different indoor units are connected under different mode exchangers, or connected under different branches of the same mode exchanger.

Possible reasons:

■ Indoor unit connecting to the wired controller which controls multiple indoor units is not in the same branch of the same mode exchanger

■ Communication connection between the IDU and mode exchanger connected to the wired controller which controls multiple indoor units is wrong

Troubleshooting:

Step 1: check if the indoor unit connected to the wired controller which controls multiple indoor units in the same branch of the same mode exchanger, if no, please connect the indoor units under different branches to different wired controllers;

Step 2: if the indoor unit connected to the wired controller which controls multiple indoor units is in the same branch of the same mode exchanger, please check if the indoor unit communication cord connected to the communication port of the corresponding branch of mode exchanger, if no, please revise the connection of communication cord;

2.125 “Ln” Lifting Panel Return Air Frame Reset Error

Error display: IDU lamp panel and IDU wired controller will display 

Applicable model: multi VRF indoor unit with the lifting panel

Error judgment condition and method:

Report alarm by judging the status of limit switch 1 and 2.

Possible reasons:

■ Poor contact between limit switch and terminal in main board interface

■ Limit switch is abnormal

■ Detecting circuit is abnormal

Troubleshooting:

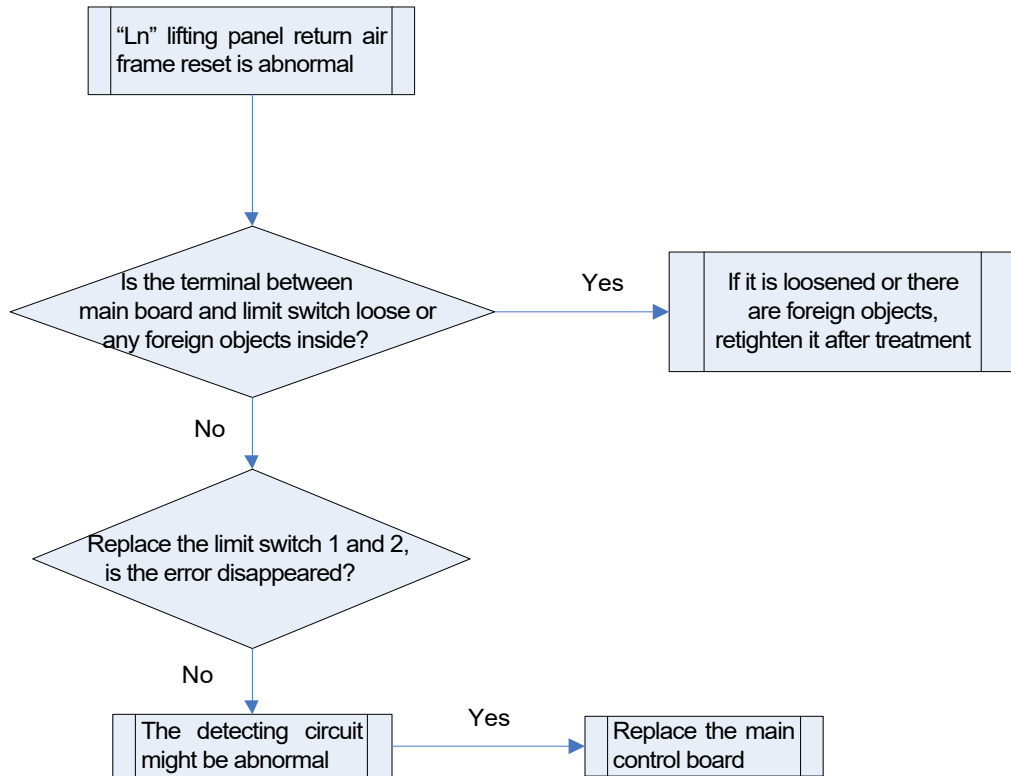

2.126 "n0" System Energy Efficiency Running Settings Status

Fault display: main board of outdoor unit, wired controller of indoor unit and receiver of indoor unit

display 

Fault diagnosis:

This is a status code of a function. It indicates that the unit has entered energy efficiency state. "00" indicates comfort as priority; "01" indicates energy efficiency as priority, in which case the unit is up to 15% more efficient.

Possible causes: --

Troubleshooting: not required.

2.127 "n2" Settings Status of Maximum Capacity Configuration Rate for Indoor and Outdoor Units

Fault display: main board of outdoor unit, wired controller of indoor unit and receiver of indoor unit

display 

Fault diagnosis:

This is a status code of a function. It indicates that the unit has entered settings status of maximum capacity configuration rate for indoor and outdoor units.

Possible causes: --

Troubleshooting: not required.

2.128 "n4" Settings Status of Maximum Output Capacity

Fault display: main board of outdoor unit, wired controller of indoor unit and receiver of indoor unit

display 

Fault diagnosis:

This is a status code of a function. It indicates that the unit has entered settings status of maximum output capacity. "10" indicates the maximum output capacity of 100%; "09" indicates the maximum output capacity of 90%; and "08" indicates the maximum output capacity of 80%.

Possible causes: --

Troubleshooting: not required.

2.129 "n6" Unit Fault Query Status

Fault display: main board of outdoor unit, wired controller of indoor unit and receiver of indoor unit

display 

Fault diagnosis:

The code is a query status code. It indicates that the unit has entered unit fault query state. In this case, you can query five historical faults of indoor and outdoor units. Keep in mind that you have to query the faults respectively for indoor units and outdoor units.

Possible causes: --

Troubleshooting: not required.

2.130 "n7" Unit Parameter Query Status

Fault display: main board of outdoor unit, wired controller of indoor unit and receiver of indoor unit

display 

Fault diagnosis:

The code is a query status code. It indicates that the unit has entered unit parameter query state.

Possible causes: --

Troubleshooting: not required.

2.131 "n8" Indoor Unit Engineering SN Query

Fault display: wired controller of indoor unit displays 

Fault diagnosis:

The code is a query status code. It indicates that the unit has entered "indoor unit engineering SN query" state. In this case the wired controller displays engineering SN of the indoor unit, the buzzer of which sounds at the same time.

Possible causes: --

Troubleshooting: not required.

2.132 "n9" Status of Querying Number of Online Indoor Units

Fault display: main board of outdoor unit displays



Fault diagnosis:

The code is a query status code, in which case you can query the number of online indoor units.

Possible causes: --

Troubleshooting: not required.

2.133 "nA" Heating and Cooling Unit

Fault display: main board of outdoor unit displays



Fault diagnosis:

The code indicates that the indoor unit operates in both heating and cooling modes.

Possible causes: --

Troubleshooting: not required.

2.134 "nH" Heating Only Unit

Fault display: main board of outdoor unit displays



Fault diagnosis:

The code indicates that the indoor unit only operates in heating mode.

Possible causes: --

Troubleshooting: not required.

2.135 "nC" Cooling Only Unit

Fault display: main board of outdoor unit displays



Fault diagnosis:

The code indicates that the indoor unit only operates in cooling mode.

Possible causes: --

Troubleshooting: not required.

2.136 "nE" Negative Number Code

Fault display: main board of outdoor unit displays



Fault diagnosis:

The code is a negative number code. It indicates that the number following the code is a negative one.

Possible causes: --

Troubleshooting: not required.

2.137 "nF" Fan Type Unit

Fault display: main board of outdoor unit displays



Fault diagnosis:

The code indicates that the indoor unit only operates in fan mode.

Possible causes: --

Troubleshooting: not required.

2.138 "o3" IDU IPM Module Protection

Error display: ODU main board and IDU wired controller will display



Applicable model: external drive DC fan

Error judgment condition and method:

Check the error code on the display board, if it displays o3, that's the IDU IPM module protection.

Possible reasons:

- Contact of the fan UVW wire is poor.
- The fan is damaged;
- The fan blade is blocked (the fan blade is blocked and the motor shaft is rusty)
- The fan drive board is abnormal;

Troubleshooting:

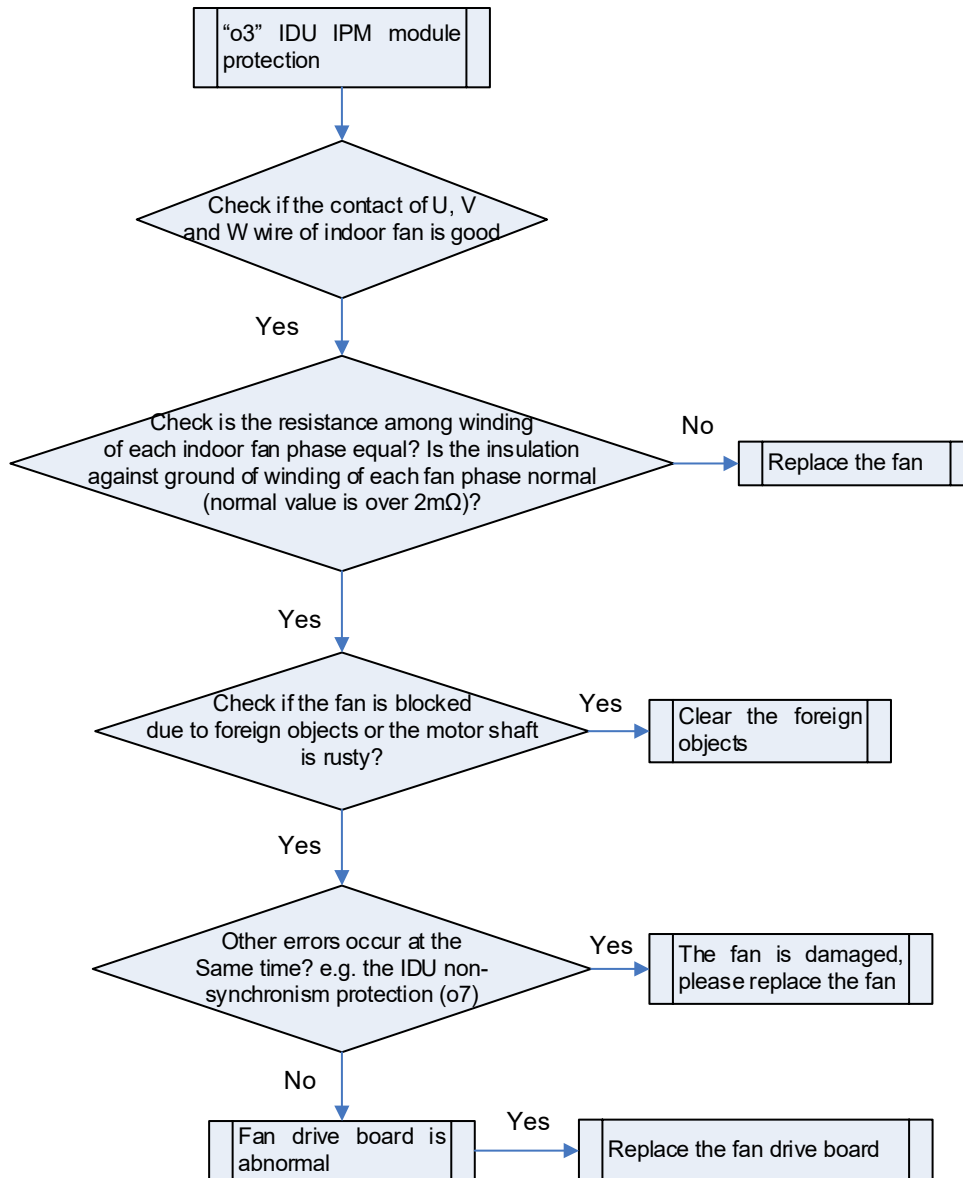

2.139 “o7” IDU Non-synchronism Protection

Error display: ODU main board and IDU wired controller will display

o7

Applicable model: external drive DC fan

Error judgment condition and method:

Check the error code on the display board, if it displays o7, that's the IDU non-synchronism protection.

Possible reasons:

- Contact of the fan UVW wire is poor;
- The fan is damaged;
- The fan blade is blocked (the fan blade is blocked and the motor shaft is rusty)
- Fan drive board is abnormal;

Troubleshooting:

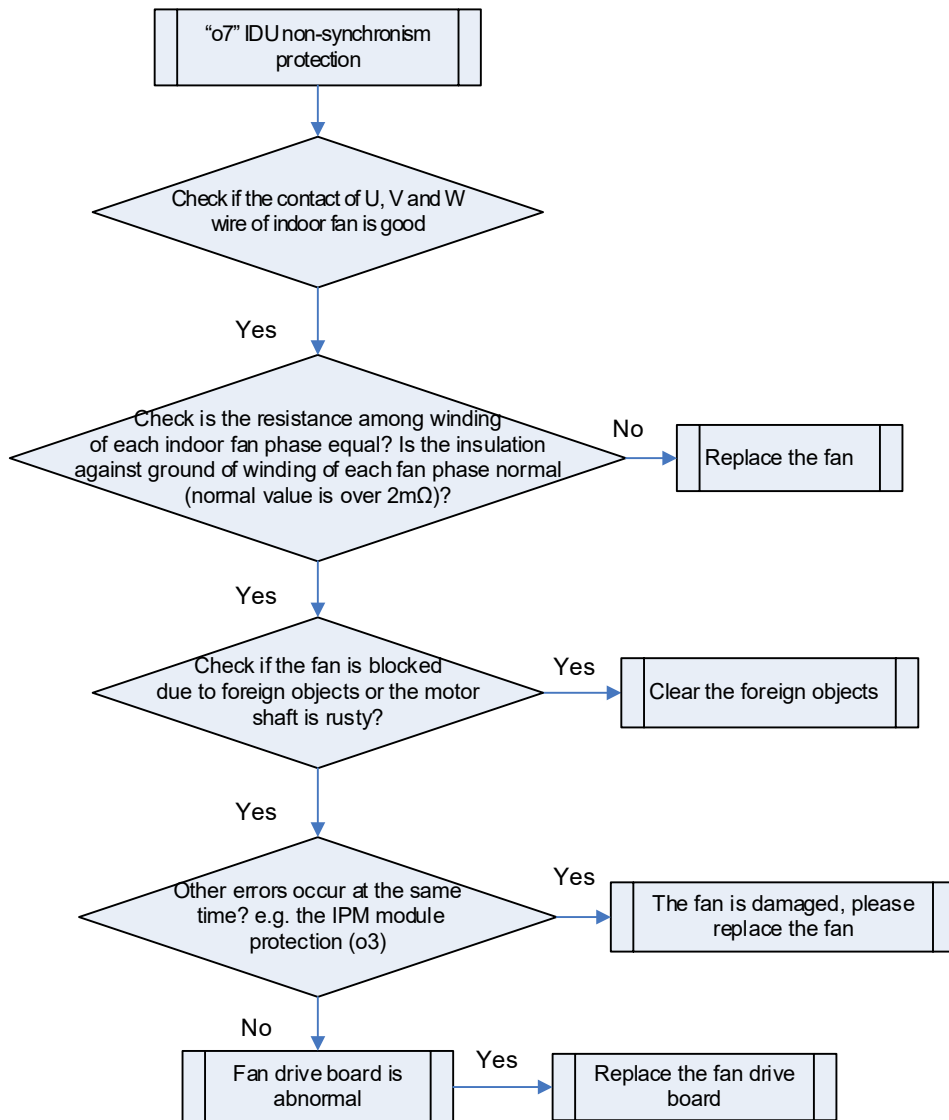

2.140 “o8” IDU Drive Communication Error

Error display: ODU main board and IDU wired controller will display



Applicable model: external drive DC fan

Error judgment condition and method:

If the drive does not receive main control data in 30 consecutive seconds, it will report communication error.

Possible reasons:

- Poor contact between drive board and main control board communication terminal
- Circuit is abnormal

Troubleshooting:

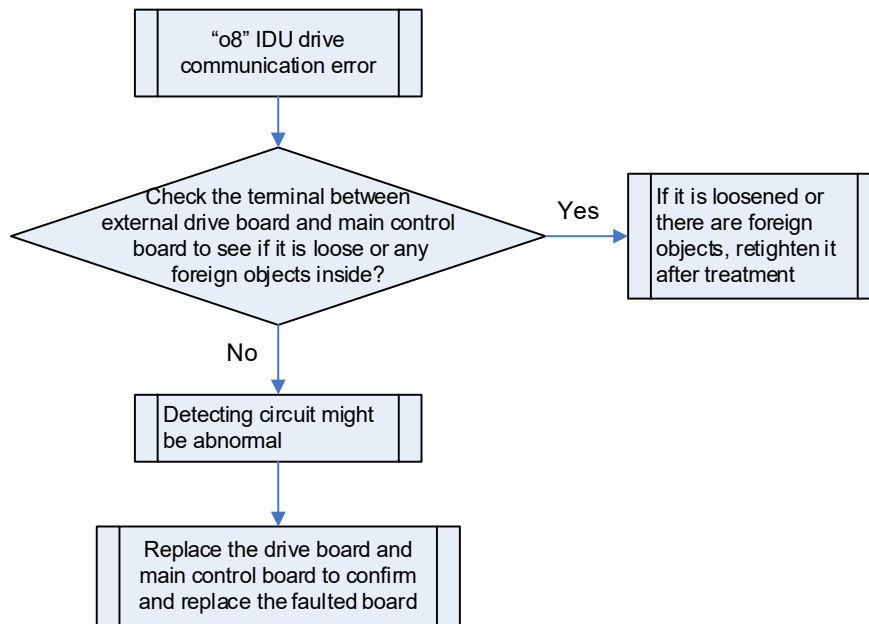

2.141 “o9” IDU Main Control Communication Error

Error display: ODU main board and IDU wired controller will display 

Applicable model: multi VRF IDU with DC motor

Error judgment condition and method:

If the main control does not receive data in 30 consecutive seconds, it will report communication error; if the drive does not receive data in 30 consecutive seconds, it will report communication error.

Possible reasons:

- Poor contact between main control board and drive board communication terminal
- Detecting circuit is abnormal

Troubleshooting:

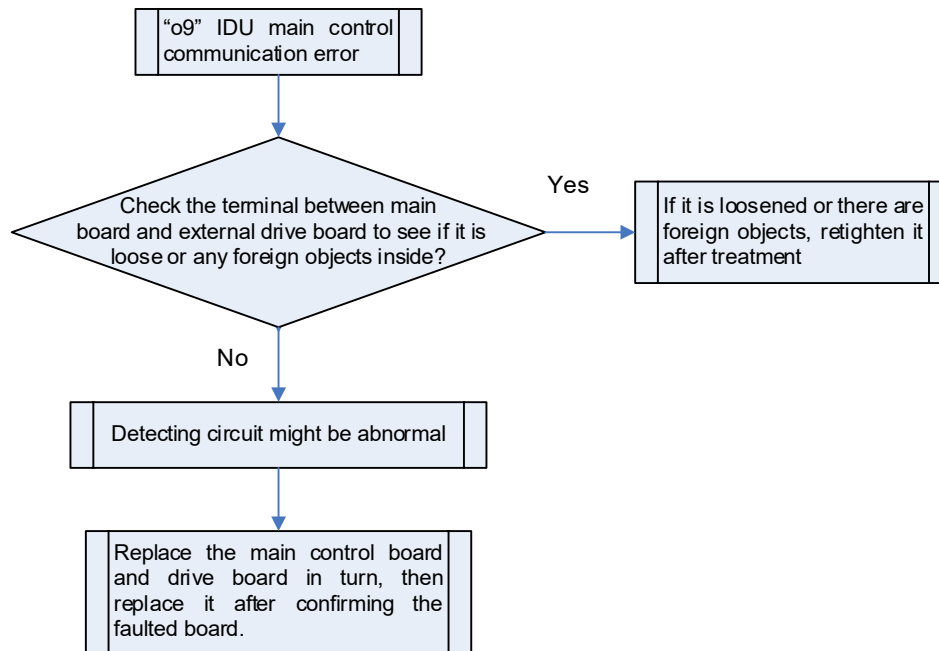

2.142 "P0" Compressor Drive Board Fault



Fault display: wired controller of indoor unit displays

Fault diagnosis: If the fault code displayed on the wired controller of the indoor unit is P0, check the fault code displayed on the 2-digit digital LED of the main control board of the outdoor unit, based on which you are able to identify the specific fault of the compressor drive board. Then, troubleshoot the fault according to the corresponding troubleshooting methods.

Possible causes:

- Compressor drive module reset protection (2-digit digital LED of the main control board of the outdoor unit displays P3);
- Temperature sensor fault of compressor drive (2-digit digital LED of the main control board of the outdoor unit displays P7);
- IPM over temperature protection for the compressor drive (2-digit digital LED of the main control board of the outdoor unit displays P8);
- Current detection circuit fault of compressor drive (2-digit digital LED of the main control board of the outdoor unit displays PC);
- Charging loop fault of compressor drive (2-digit digital LED of the main control board of the outdoor unit displays PF);
- Loss of synchronization protection for the inverter compressor (2-digit digital LED of the main control board of the outdoor unit displays P9);
- Inverter compressor startup failure (2-digit digital LED of the main control board of the outdoor unit displays PJ).

Troubleshooting: based on the faults displayed on the main board of the outdoor unit.

2.143 "P1" Malfunctioning Compressor Drive Board

Fault display: wired controller of indoor unit displays



Fault diagnosis:

If the fault code displayed on the wired controller of the indoor unit is P1, check the fault code displayed on the 2-digit digital LED of the main control board of the outdoor unit, based on which you are able to identify the specific fault of the compressor drive board. Then, troubleshoot the fault according to the corresponding troubleshooting methods.

Possible causes:

- Inverter compressor over-current protection (2-digit digital LED of the main control board of the outdoor unit displays P5);
- IPM module protection for the compressor drive (2-digit digital LED of the main control board of the outdoor unit displays P6);
- Communication fault of compressor drive (2-digit digital LED of the main control board of the outdoor unit displays C2).

Troubleshooting: based on the faults displayed on the main board of the outdoor unit.

2.144 "P2" Input Voltage Protection for the Compressor Drive Board

Fault display: wired controller of indoor unit displays



Fault diagnosis:

If fault code displayed on the wired controller of the indoor unit is P2, check the fault code displayed on the 2-digit digital LED of the main control board of the outdoor unit, based on which you are able to identify the specific fault of the compressor drive board. Then, troubleshoot the fault according to the corresponding troubleshooting methods.

Possible causes:

- Over voltage protection for the DC bus of compressor drive (2-digit digital LED of the main control board of the outdoor unit displays PH);
- Under voltage protection for the DC bus of compressor drive (2-digit digital LED of the main control board of the outdoor unit displays PL).

Troubleshooting: based on the faults displayed on the main board of the outdoor unit.

2.145 "P3" Reset Protection for the Compressor Drive Module

Fault display: main board of outdoor unit displays



Fault diagnosis:

If the fault code displayed on the 2-digit digital LED of the outdoor unit's main control board is P3, it indicates the reset protection for the compressor drive board.

Possible causes:

- The compressor drive operates improperly

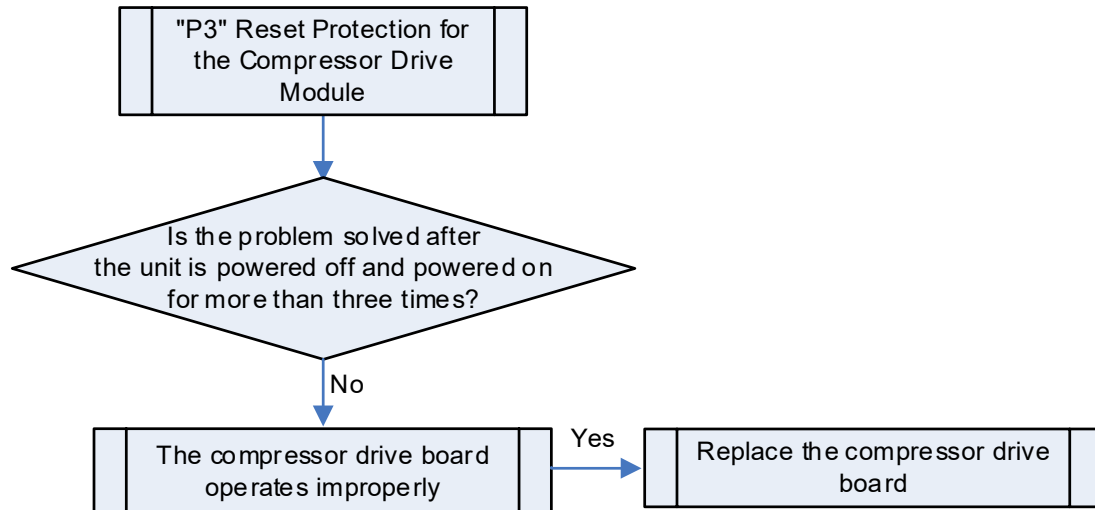
Troubleshooting:**2.146 "P5" Inverter Compressor Over-current Protection**

Fault display: main board of outdoor unit displays

Fault diagnosis:

If the fault code displayed on the 2-digit digital LED of the outdoor unit's main control board is P5, it indicates the over-current protection for the inverter compressor.

Possible causes:

- Poor contact of compressor's UVW cables;
- The compressor's UVW cables are wrongly connected;
- The compressor is damaged;
- The system is blocked;
- IPM module of the compressor drive board is damaged.

Troubleshooting:

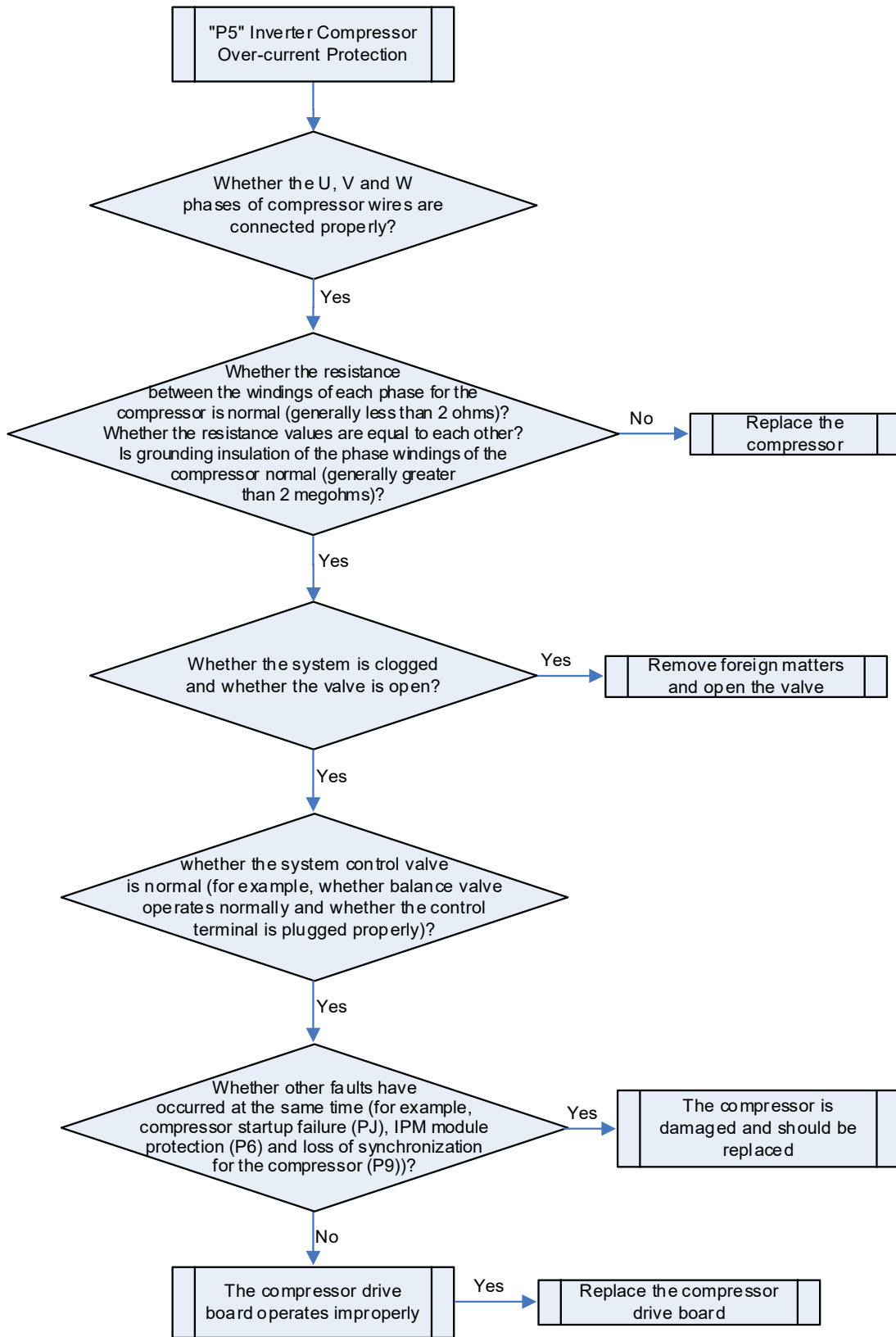

2.147 "P6" IPM Module Protection for the Compressor Drive



Fault display: main board of outdoor unit displays

Fault diagnosis:

If the fault code displayed on the 2-digit digital LED of the outdoor unit's main control board is P6, it indicates the IPM module protection for the compressor drive.

Possible causes:

- Poor contact of compressor's U/V/W cables;
- The compressor's U/V/W cables are wrongly connected;
- The compressor is damaged;
- The system is blocked;
- IPM module of the compressor drive board is damaged.

Troubleshooting:

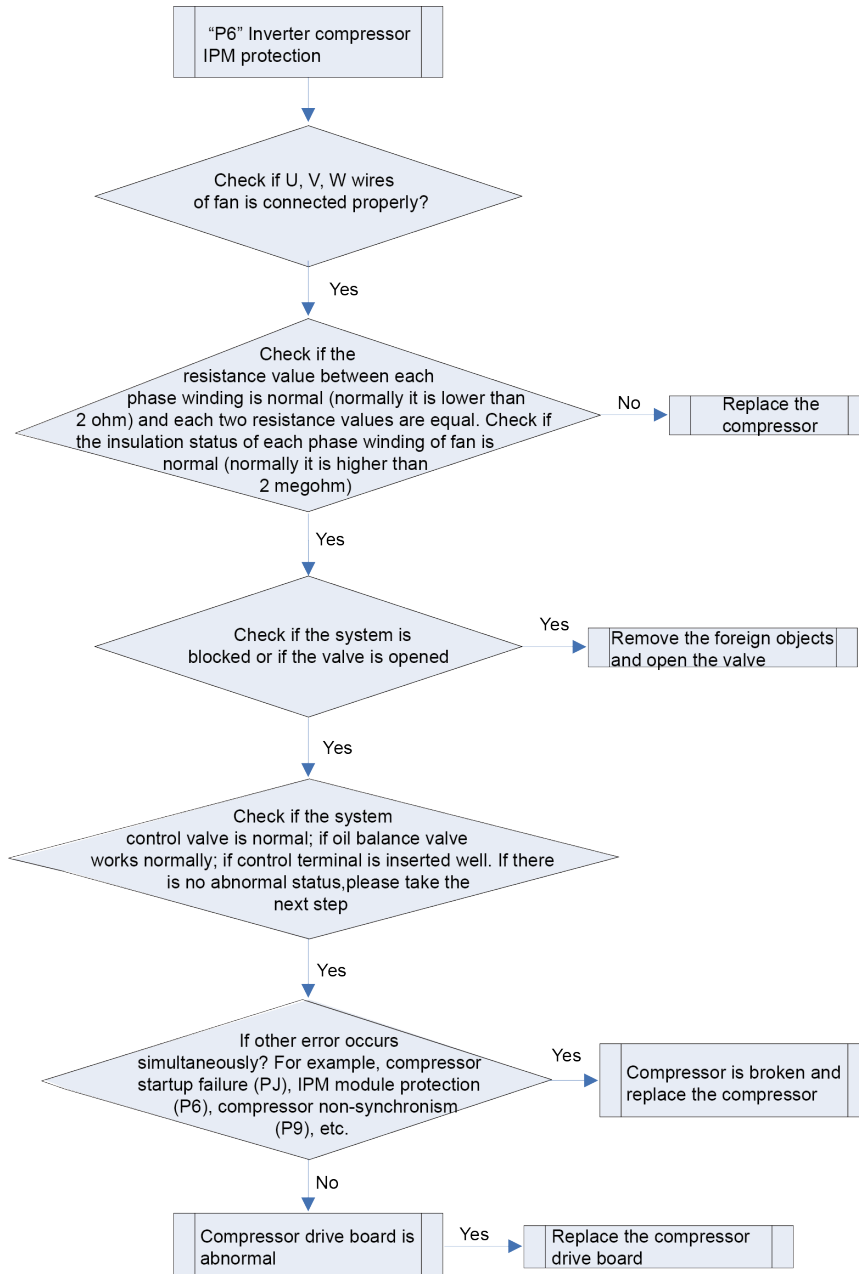

2.148 "P7" Abnormal Temperature Sensor of Compressor Drive Board



Fault display: main board of outdoor unit displays

Fault diagnosis:

If the fault code displayed on the 2-digit digital LED of the outdoor unit's main control board is P7, it indicates the abnormal temperature sensor of compressor drive board.

Possible causes:

- The compressor drive board operates improperly.

Troubleshooting:

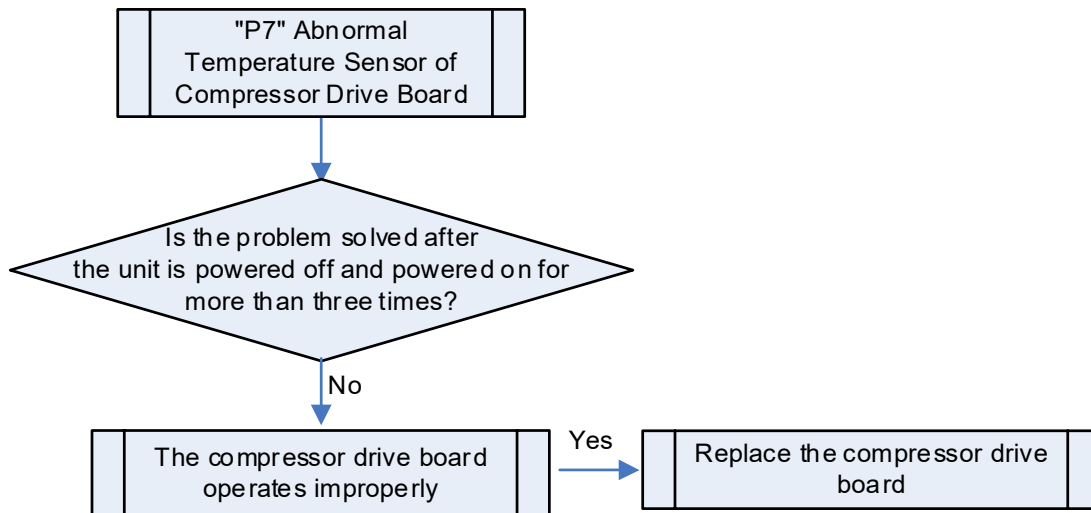

2.149 "P8" IPM Over Temperature Protection for Compressor Drive Board



Fault display: main board of outdoor unit displays

Fault diagnosis:

If the fault code displayed on the 2-digit digital LED of the outdoor unit's main control board is P8, it indicates the IPM over temperature protection for the compressor drive.

Possible causes:

- The IPM module's screws are not tightened;
- The IPM module is not covered, or unevenly covered by thermal grease, or covered by dried thermal grease;
- The compressor drive board operates improperly.

Troubleshooting:

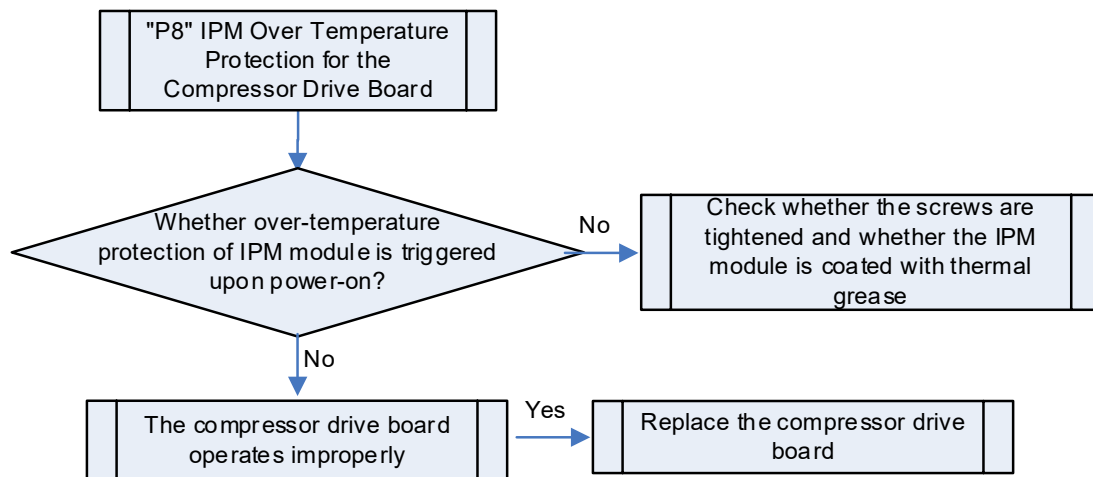

2.150 "P9" Loss of Synchronization Protection for Inverter Compressor

Fault display: main board of outdoor unit displays



Fault diagnosis:

If the fault code displayed on the 2-digit digital LED of the outdoor unit's main control board is P9, it indicates the loss of synchronization protection for the inverter compressor.

Possible causes:

- The compressor drive board operates improperly.
- The compressor is damaged.

Troubleshooting:

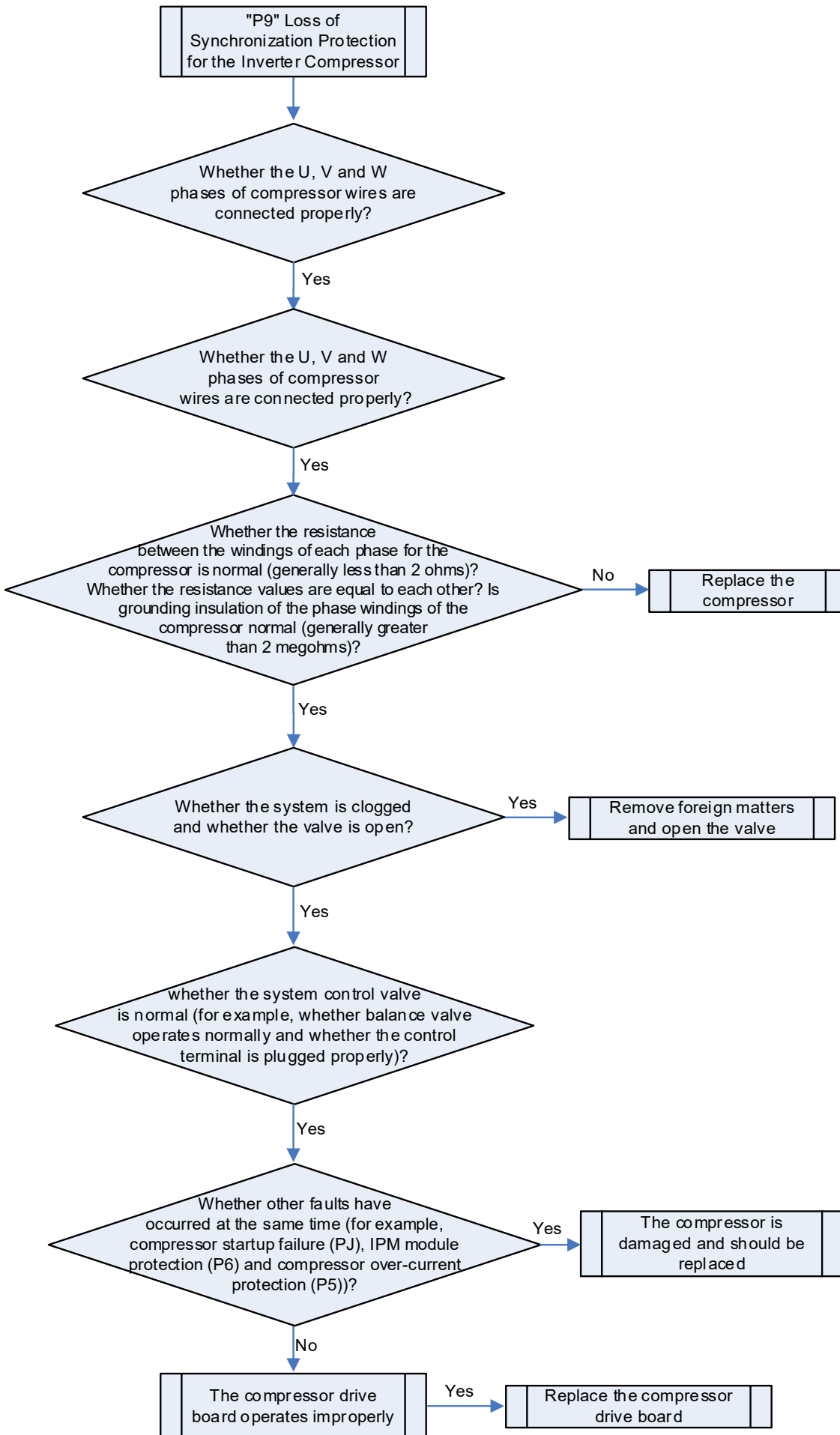

2.151 "PC" Current Detection Circuit Fault of Compressor Drive

Fault display: main board of outdoor unit displays



Fault diagnosis:

If the fault code displayed on the 2-digit digital LED of the outdoor unit's main control board is PC, it indicates the current detection circuit fault of compressor drive.

Possible causes:

- The compressor drive board operates improperly.

Troubleshooting:

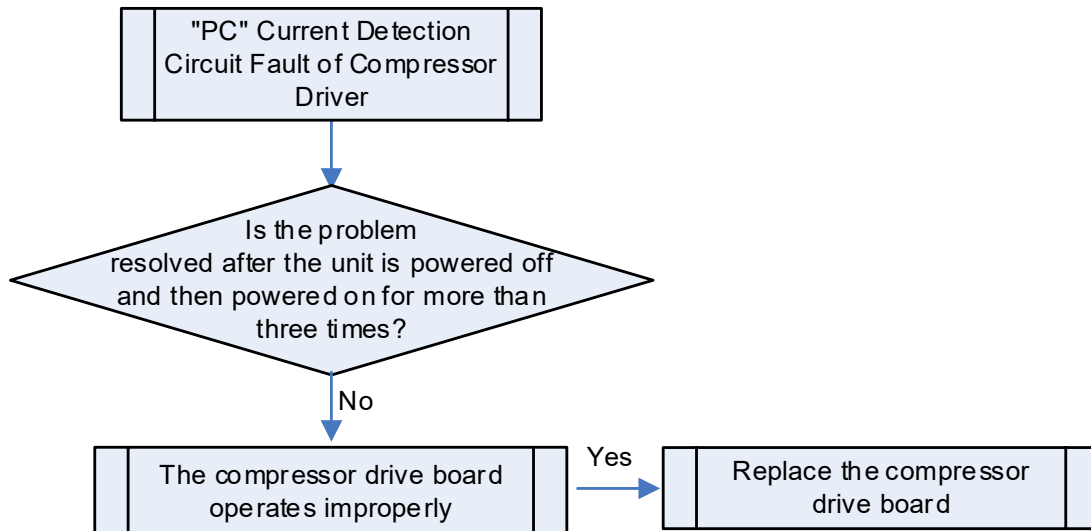

2.152 "PH" Over Voltage Protection for DC Bus of Compressor Drive

Fault display: main board of outdoor unit displays



Fault diagnosis:

When the input power cable of the main board has a voltage over 460 V, the unit triggers protection against faults.

Possible causes:

- The unit's input power cable has a voltage exceeding 460 V;
- The compressor drive board operates improperly.

Troubleshooting:

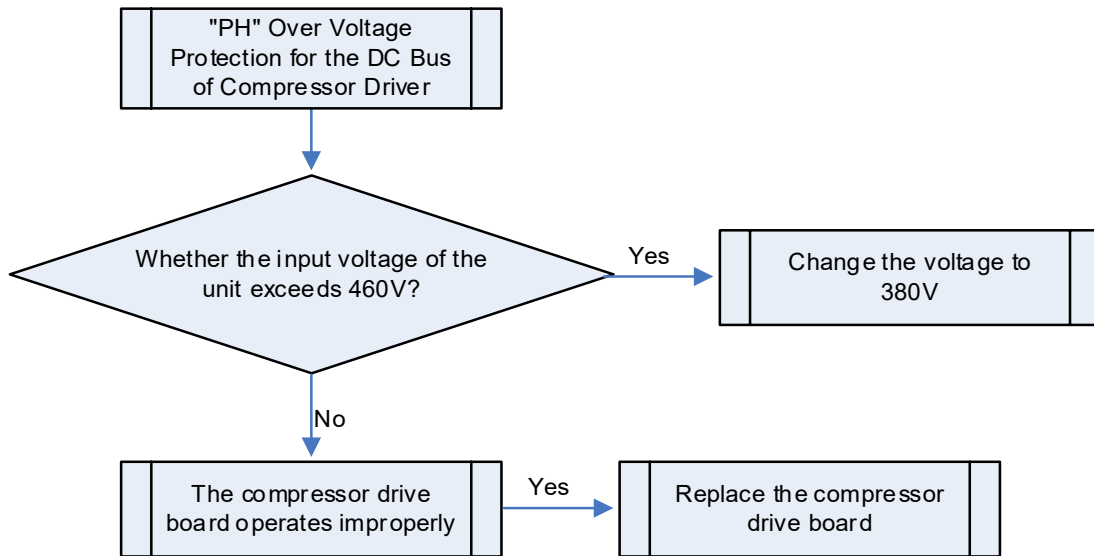

2.153 "PL" Under Voltage Protection for DC Bus of Compressor Drive



Fault display: main board of outdoor unit displays

Applicable models: GMV6, GMV5, GMV5S series

Fault diagnosis:

When the input power cable of the main board has a voltage below 320 V, the unit triggers protection against faults.

Possible causes:

- The unit's input power cable has a voltage below 320V;
- The compressor drive board operates improperly.

Troubleshooting:

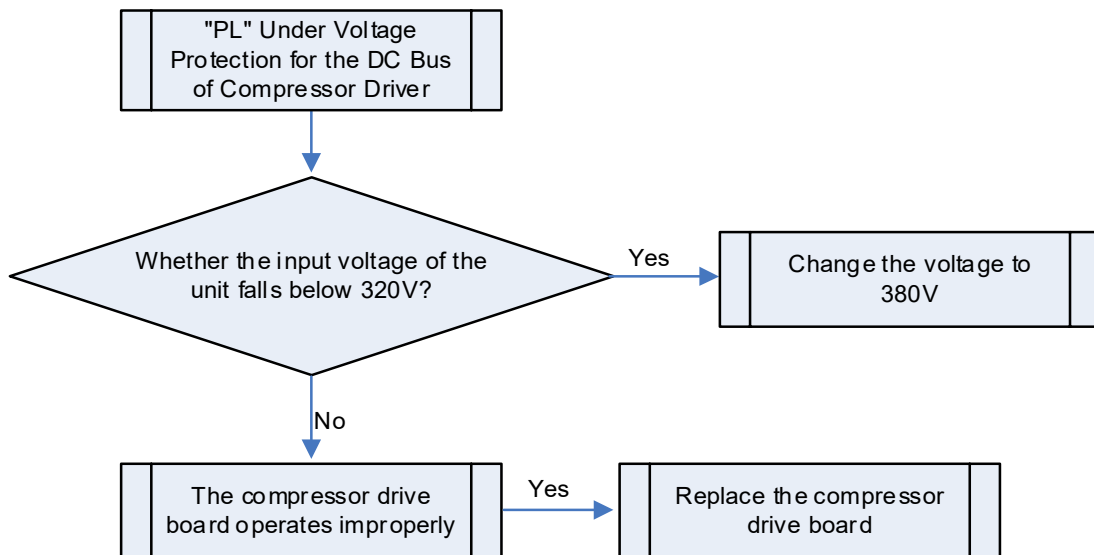

2.154 "PJ" Inverter Compressor Startup Failure



Fault display: main board of outdoor unit displays

Fault diagnosis:

If the fault code displayed on the 2-digit digital LED of the outdoor unit's main control board is PJ, it indicates the inverter compressor startup failure.

Possible causes:

- Poor contact of compressor's UVW cables;
- The compressor is damaged;
- The compressor drive board operates improperly.

Troubleshooting:

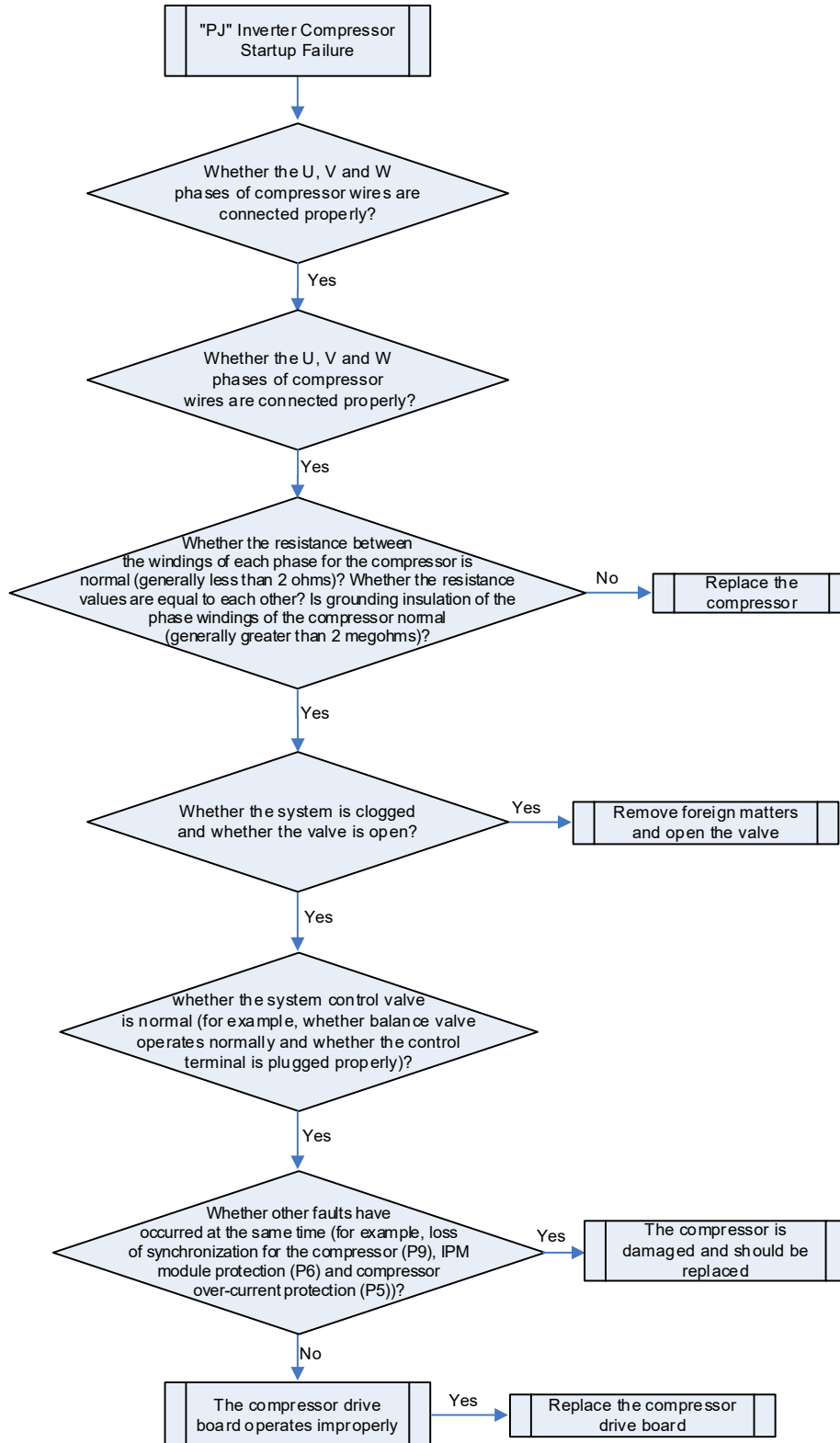

2.155 "U0" Insufficient Warm-up Time for Compressor

Fault display: main board of outdoor unit, wired controller of indoor unit and receiver of indoor unit

display 

Fault diagnosis:

When the oil preheating period of time before compressor starts is less than eight hours, the unit generates a fault.

Possible causes: --

Troubleshooting: Warm up the whole unit for more than eight hours before startup.

2.164 "U2" Incorrect Settings of Outdoor Unit Capacity DIP Switch/Jumper Cap

Fault display: main board of outdoor unit, wired controller of indoor unit and receiver of indoor unit

display 

Applicable models: all outdoor units

Fault diagnosis:

When the capacity DIP switch detected by the outdoor unit's main board is inconsistent with the unit's actual capacity, or the jumper cap value detected by the outdoor unit's main board is inconsistent with the actual unit, the fault is generated.

Possible causes:

- Capacity DIP switch error or jumper cap error (for some models without jumper caps, jumper cap error is not detected)
- DIP switch or jumper cap is broken
- Abnormal detection circuit

Troubleshooting:

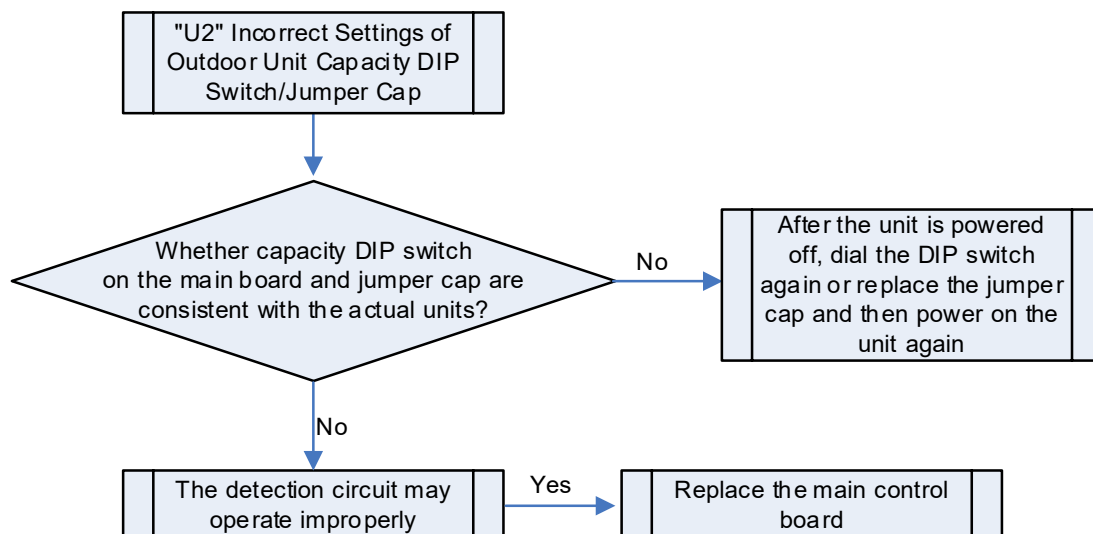

2.156 "U3" Power Phase-Sequence Protection

Fault display: main board of outdoor unit, wired controller of indoor unit and receiver of indoor unit

display 

Fault diagnosis:

Check the three-phase power of the unit. If the power is connected incorrectly, thereby causing phase loss or reverse phase, the unit generates a fault.

Possible causes:

- The power is connected wrongly or phase loss or reverse phase occurs
- Abnormal detection circuit

Troubleshooting:

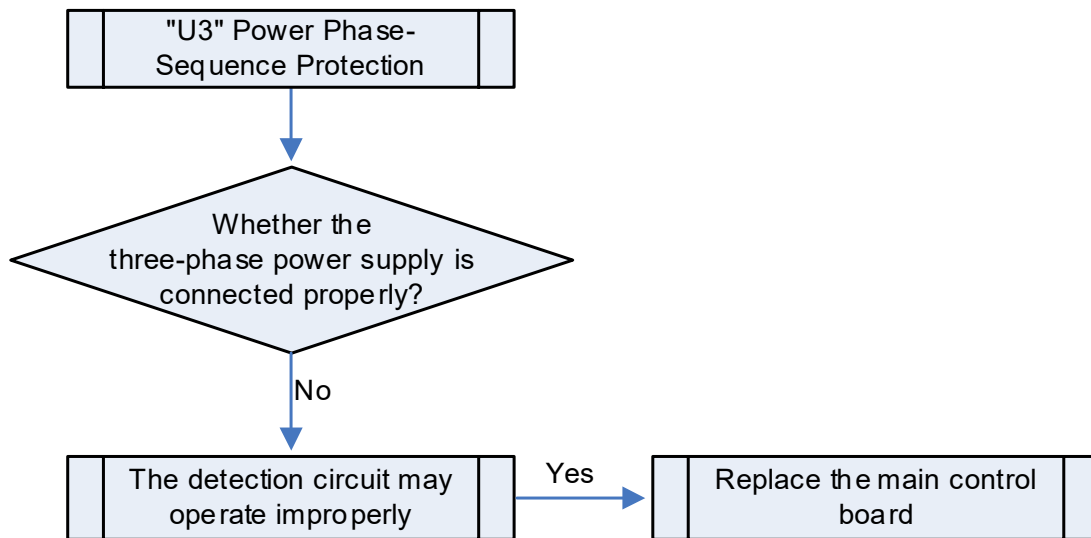

2.157 "U4" Refrigerant Loss Protection

Fault display: main board of outdoor unit, wired controller of indoor unit and receiver of indoor unit

display 

Fault diagnosis:

Check the high pressure and the low pressure of the unit by the pressure sensor. If the temperatures corresponding to the high pressure and the low pressure of the unit are below the ambient temperature for over 5, the unit will not start operation for safety purpose.

Possible causes:

- Insufficient refrigerant in the unit;
- The pipes leak.

Troubleshooting:

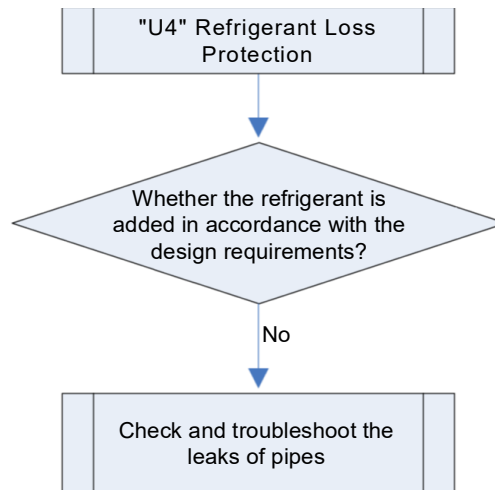

2.158 "U6" Abnormal Valve Prompt

Fault display: main board of outdoor unit, wired controller of indoor unit and receiver of indoor unit

display 

Fault diagnosis:

During commissioning process, determine whether the check valve of the outdoor unit is open by detecting the unit's parameters by the pressure sensor. If the parameters are abnormal, the unit prompts you to confirm whether you want to open the check valve again. After confirmation, press SW4 to proceed.

Possible causes:

- The check valve of the outdoor unit is not open.

Troubleshooting: Reconfirm and open the check valve of the outdoor unit.

2.159 "U8" Abnormal Pipes of the Indoor Unit

Fault display: main board of outdoor unit, wired controller of indoor unit and receiver of indoor unit

display 

Fault diagnosis:

During commissioning process, check the temperature of the indoor unit's pipes to determine whether the pipes are blocked. Any abnormal parameters found would indicate that the unit has the fault.

Possible causes:

- The electronic expansion valve operates improperly;
- The indoor unit's pipes are blocked.

Troubleshooting:

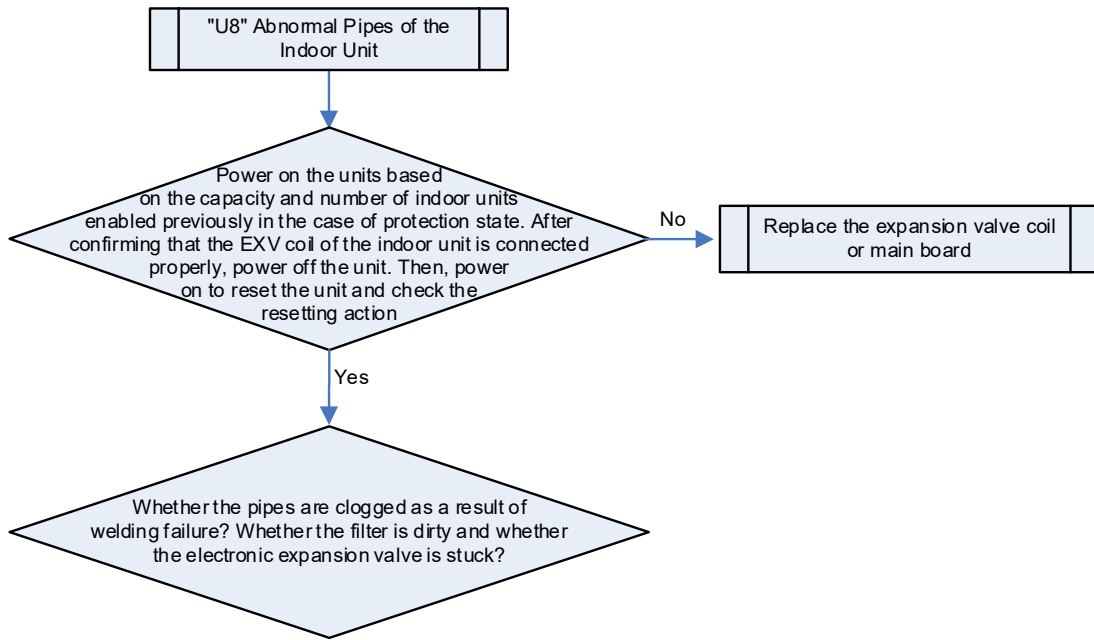

2.160 "U9" Abnormal Pipes of Outdoor Unit

Fault display: main board of outdoor unit, wired controller of indoor unit and receiver of indoor unit



Fault diagnosis:

During commissioning process, check the pressure of the unit to determine whether the pipes of the outdoor unit are blocked. Any abnormal parameters found would indicate that the unit has the fault.

Possible causes:

- The electronic expansion valve operates improperly;
- The outdoor unit's pipes are blocked.

Troubleshooting:

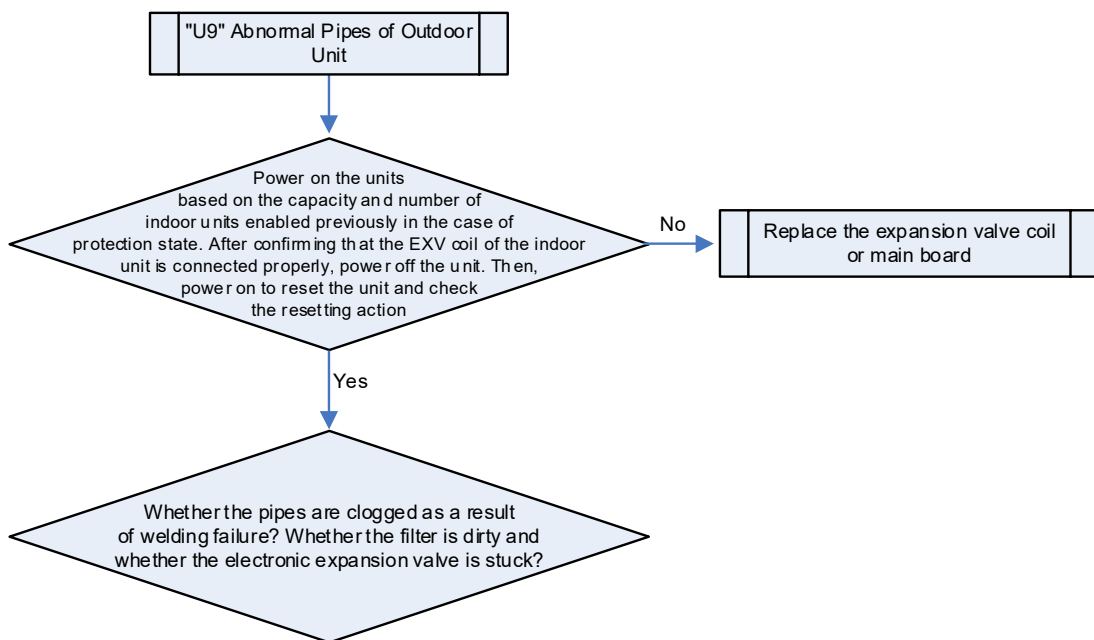

2.161 "UC" Master Indoor Unit Set Successfully

Fault display: main board of outdoor unit, wired controller of indoor unit and receiver of indoor unit

display 

Fault diagnosis:

The code indicates the state of the unit rather than the fault. During the commissioning process, the unit prompts that the master indoor unit is already set successfully.

Possible causes: --

Troubleshooting: --

2.162 "UL" DIP Switch Error of Compressor Emergency Operation

Fault display: main board of outdoor unit, wired controller of indoor unit and receiver of indoor unit

display 

Fault diagnosis:

The fault is displayed when the DIP switch of compressor emergency operation is not set within the reasonable range.

Possible causes: --

Troubleshooting: Re-dial the DIP switch according to the DIP switch table.

2.163 "UE" Auto Refrigerant Charging Void

Fault display: main board of outdoor unit, wired controller of indoor unit and receiver of indoor unit

display 

Fault diagnosis:

The code is displayed when the outdoor ambient temperature exceeds the range of auto refrigerant charging (the normal range of charging refrigerant automatically is 0-40°C).

Possible causes: --

Troubleshooting: Disable the auto refrigerant charging. Instead, charge the refrigerant manually.

2.164 "UF" Mode Exchanger IDU Identification Abnormal

Error display: mode exchanger main board will display 

Applicable mode: mode exchange box

Error judgment condition and method:

IDU main board is not compatible with the mode exchange box main board, which might trigger the identification abnormality error of mode exchanger IDU.

Possible reasons:

- IDU and mode exchanger is not compatible
- Mode exchanger main board is damaged

Troubleshooting:

Step 1: replace mode exchanger main board to see if the error is solved;

Step 2: if UF error still exists after replacing mode exchanger main board, disconnect the communication connection of all IDUs and mode exchangers, connect the IDU communication cord one by one to the communication board of mode exchanger until all the IDUs which have triggered the UF error are tested;

Step 3: update the program for the IDU which triggers UF error or replace the main board.

2.165 “y7” Fresh Air Inlet Temperature Sensor Error

Error display: ODU main board and IDU wired controller will display 

Applicable model: multi VRF indoor unit with fresh air function

Error judgment condition and method:

Sample the AD value of temperature sensor through temperature sensor detecting circuit and judge the range of AD value. If the sampling AD value exceeds upper limit and lower limit in 5 seconds continuously, report the error

Possible reasons:

- Poor contact between air inlet temperature sensor and main board interface terminal
- Air inlet temperature sensor is abnormal
- Detecting circuit is abnormal

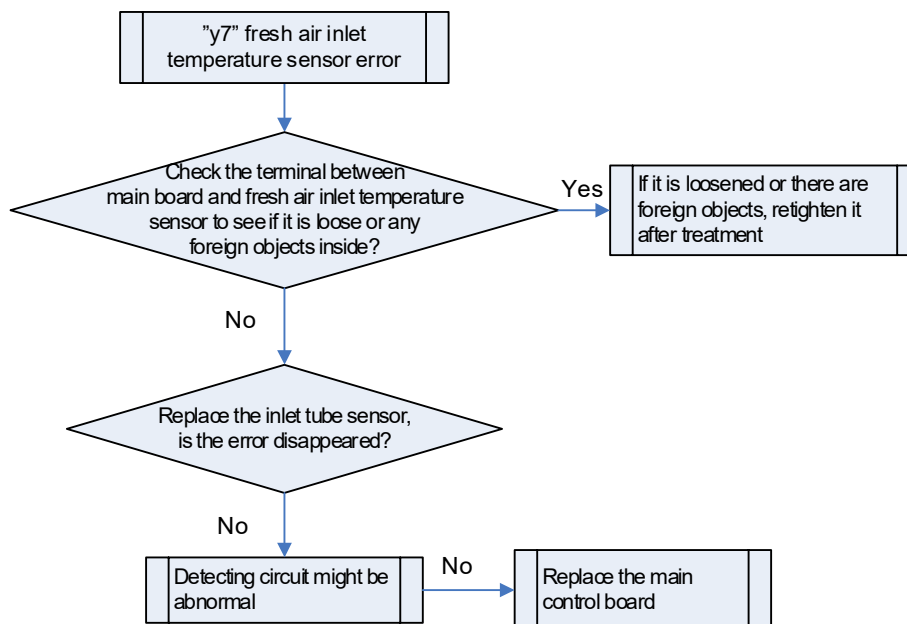
Troubleshooting:**2.166 “yA” IFD Error**

Error display: ODU main board and IDU wired controller will display 

Applicable model: high-end fresh air floor standing unit

Error judgment condition and method:

After turning on the IFD for 60s, start the error feedback test, if the IFU feedback tested in 5 consecutive seconds is low level, it's deemed that IFD is faulted.

Possible reasons:

- Poor contact between IFD feedback side and main board interface terminal
- IFD abnormality
- Detecting circuit is abnormal

Troubleshooting:

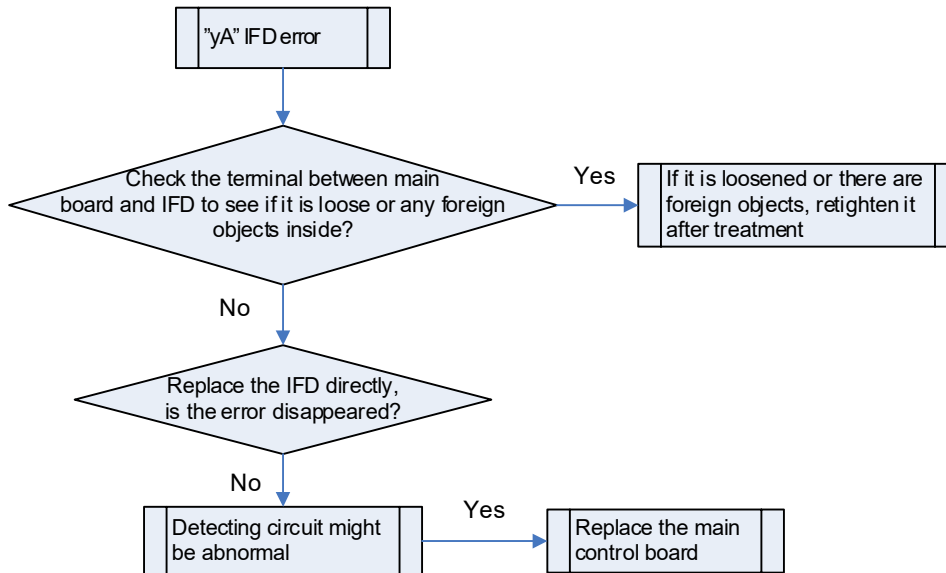

2.167 “y8” Indoor Air Box Sensor General Error

Error display: ODU main board and IDU wired controller will display



Applicable model: IDU with air box

Error judgment condition and method:

Main board, air box communication abnormality and air box test data (temperature, humidity and CO₂ concentration or PM2.5 concentration) has exceeded the set upper and lower limiting value.

Possible reasons:

- Poor contact between main control board and air box communication terminal
- Air box detection is abnormal

Troubleshooting:

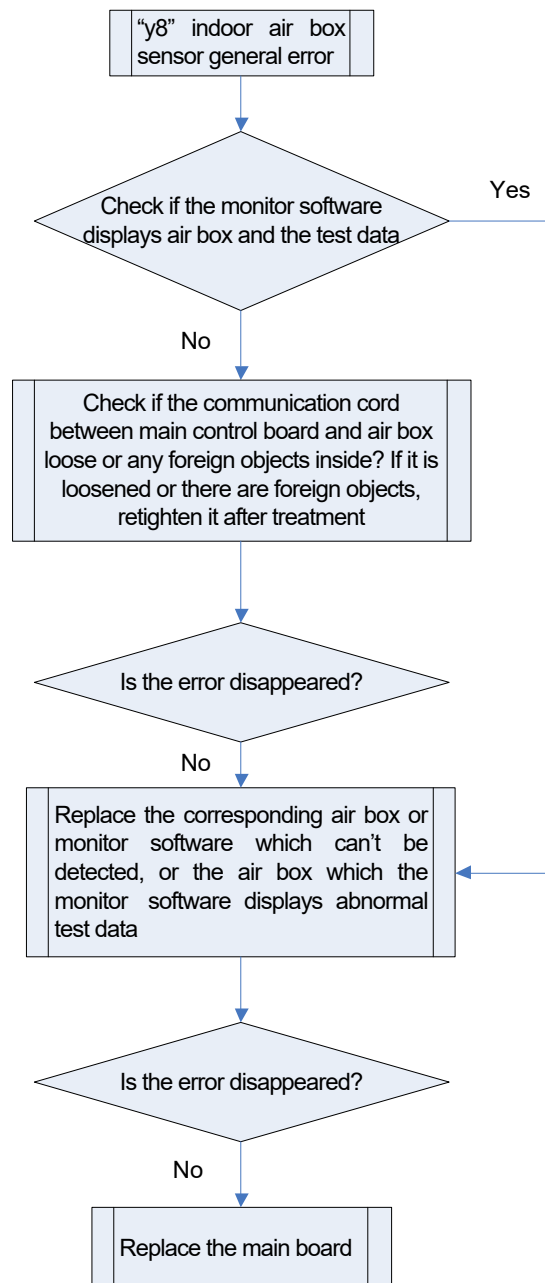

2.168 Ineffective Cooling and Heating

Applicable models: all indoor units

Fault diagnosis:

- 1) In cooling mode, when the electronic expansion valve is open to 2000PLS, the temperature of outlet pipes of the indoor unit coil is over 5°C greater than the temperature of inlet pipes of the indoor unit coil;
- 2) In heating mode, when the electronic expansion valve is open to 2PLS, the temperature of inlet pipes of the indoor unit coil is over 12°C less than the saturation temperature corresponding to the high pressure;

Possible causes:

- The check valve of the outdoor unit is not opened fully as required.
- The unit pipes are clogged.

- The unit operates out of the range of required ambient temperature.
- Airflow organization is set ineffectively.
- The amount of refrigerant is insufficient.

Troubleshooting:

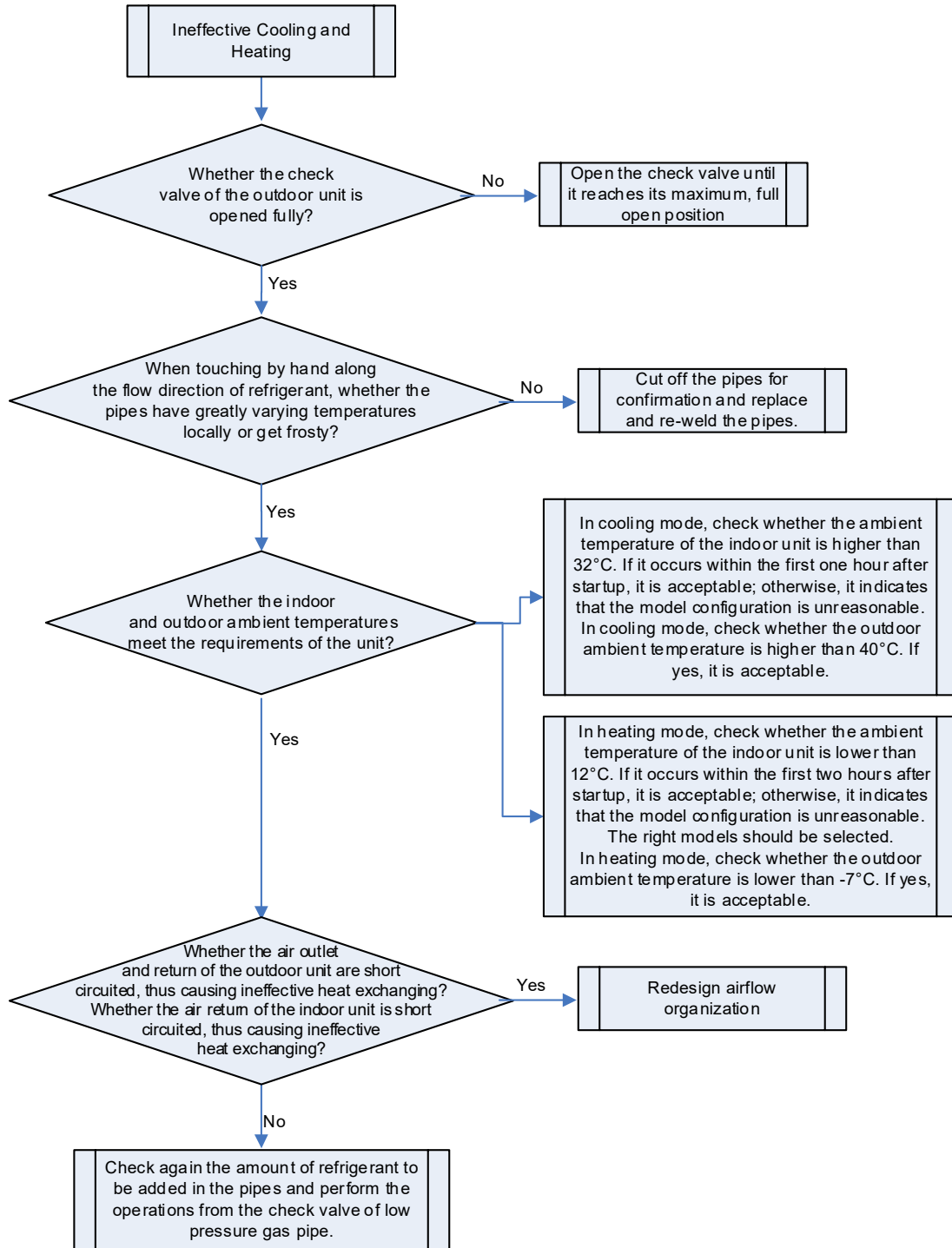

2.169 No Faults Displayed But Compressor Not Starting in Cooling/Heating Mode

Error display: no error displayed but compressor not starting in cooling / heating mode

Applicable model: all ODUs

Error judgment condition and method:

Under shutdown status, the high pressure sensor has detected that the high pressure of the module is 55°C or higher, or the discharge temperature sensor / shell top temperature sensor has detected that the temperature is 105°C or higher.

Possible reasons:

- The ambient temperature is 55°C or higher;
- The temperature of the compressor is 105°C or higher;
- High pressure sensor is abnormal;
- Temperature sensor is abnormal;

Troubleshooting:

Step 1: confirm the ambient temperature is below 55°C, otherwise the compressor cannot start;

Step 2: detect the temperature of the compressor, if the temperature is over 104°C, the compressor cannot start;

Step 3: if the above inspections are normal, connect the multi-functional debugger;

Step 4: if the high pressure of the module is 55 or higher, replace the high pressure sensor;

Step 5: if the discharge temperature / shell top temperature of the compressor is 105 or higher, replace the temperature sensor.

3 Non-fault Type Troubleshooting

⚠ WARNING

- (1) If an abnormal situation (such as peculiar smell) occurs, please stop the operation immediately and turn off the main power supply, and then contact Gree authorized maintenance center. If the unit continues to operate under abnormal situation, the air conditioner will be damaged and an electric shock or fire accident may result.
- (2) Do not maintain the air conditioner by yourself, misoperation may cause electric shock or fire hazard. Please contact professional personnel of Gree authorized maintenance center to maintain.
- Before asking for maintenance, please check the following issues first.

Phenomenon	Causes	Troubleshooting
Air conditioner can't operate	Fuse is broken or circuit breaker is open	Replace fuse or close the circuit breaker
	Power failure	Restart up the unit and then the unit will operate
	Power supply is not connected	Connect the power supply
	The power for batteries of remote controller is insufficient	Replace the batteries
	Remote controller is not within the remote control range	Remote control range is within 8m
Air conditioner operates, while it stops operation immediately	Air inlet or air outlet of indoor unit/outdoor unit is blocked	Eliminate the obstacles
Cooling or heating is abnormal	Air inlet or air outlet of indoor unit/outdoor unit is blocked	Eliminate the obstacles
	Temperature setting is improper	Adjust temperature setting by remote controller or wired controller
	Fan speed is set too low	Adjust fan speed setting by remote controller or wired controller
	Fan direction is not correct	Adjust fan direction setting by remote controller or wired controller
	Door or window is open	Close door and window
	Direct sunshine	Hang curtains or window shade at the window
	Too many persons in the room	—
	Too many thermal source in the room	Reduce the thermal source
	The filter is dirty and blocked	Clean the filter

NOTICE

If problem cannot be solved after checking the above items, please contact Gree service center and describe the cases and models.

- Following circumstances are not malfunctions.

Phenomenon		Causes
Unit doesn't run	When unit is started immediately after it is just turned off	Overload protection switch makes it run after 3 minutes delay
	When power is turned on	Standby operating for about 1 minute
Mist comes from the unit	Under cooling	Indoor high humidity air is cooled rapidly
Noise is emitted	When the power supply is connected, there is small "dada" sound.	It is the sound of startup action of electronic expansion valve.
	When the system is conducting cooling or defrosting, there is continuous "sa——" sound.	This is the sound of refrigerant flowing inside the unit.
	When the system is switching cooling and heating modes; during heating operation, the unit enters or quits defrosting operation or oil return operation, there is "chi——" sound.	This is the sound for direction reversal of 4-way valve.

Phenomenon		Causes
Noise is emitted	When the system is started or stopped for a short time, you can hear the sound of “sa——”; you can also hear this sound for a short time after the start or stop of the defrosting operation.	This is the sound produced when the refrigerant stops or changes the flow.
	When the system is in cooling operation or after it stops running, a continuous “sa ——” sound can be heard	This is the operation sound of drain system.
	When the system is running or after it stops running, a “creaking” sound can be heard.	This is the sound produced when plastic parts such as panel expansion and contraction due to temperature changes.
	When the system is in heating operation, after the indoor unit stops running, the sound like running water can be heard.	The unit is melting the frost on the outdoor unit, please wait about 10 minutes (due to different unit models, the waiting time will vary).
	When the indoor unit stops running, a faint “sa——” sound or “gurgling” sound can be heard.	This sound can be heard when other indoor units are running. This is to prevent oil and refrigerant from staying in the indoor unit, and to keep a small amount of refrigerant flowing.
	When the unit is running, the operating sound of the compressor changes.	This is caused by changes in compressor operating frequency.
	During the operation of the unit or after the operation is started or stopped, a continuous “sa ——” sound can be heard.	This is the sound produced when the refrigerant bypass valve operates.
	When the operating mode of the unit changes, the indoor unit and outdoor unit will produce “sa ——” and “gurgling” sounds.	This is the sound produced when the refrigerant stops or changes flow.
	The sound from the outdoor unit can be heard indoors	This is because the outdoor unit is installed close to the window or wall, and the sound insulation is poor, and the external noise is transmitted in.
There is dust blowing out from the unit	Start operation after it is not used for a long time	Dust in indoor unit is blew out
The unit emits odor	Operating	The odor of the air conditioner is sucked into the room and then blown out
The indoor unit is still running after shutting down	The indoor unit is still running after shutting down	The fan of indoor unit will continue to work for 20 to 70 seconds to fully use the residual cooling or heat of the heat exchanger, and to prepare for the next use.
Mode conflict	Cooling or heating mode cannot start up	When the selected operation mode of the indoor unit conflicts with the operation mode of the outdoor unit, after five seconds, the indoor unit error indicator flashes or the remote controller displays the operation conflict, and the indoor unit shuts down. At this time, the indoor unit can be converted to run with the outdoor unit. The mode can be restored to normal without conflict. The cooling mode and dry mode do not conflict, and the air supply does not conflict with any mode.

Phenomenon		Causes
Wired controller displays A3 code	Unit enters frost mode operation	During cold weather heating operation, when frost or ice may form on the outdoor unit heat exchanger, the unit will automatically enter the defrost mode for a few minutes.
Wired controller displays A4 code	Unit enters oil-return mode operation	When the outdoor unit runs for a certain time, it will automatically enter the oil return mode to run for a few minutes to ensure that the internal compression of the external machine is effectively lubricated.

Chapter 4 Maintenance

WARNING!

During the maintenance of a modular unit, all the outside units must be powered on and off concurrently. Avoid doing so to only some of the outdoor units.

1 Precautions for Refrigerant Leakage

- (1) AC project designers and installers shall obey the local laws and regulations on the safety requirements toward the usage and leakage of refrigerant.
- (2) The multi VRF unit adopts R410A refrigerant. When installing the unit in the space where people included, the refrigerant's amount shall not exceed the maximum allowable concentration. Otherwise, suffocation will occur to the people nearby. For example, the maximum refrigerant's allowable concentration for European safety standard and regulation is 0.44kg/m^3 .

Maximum refrigerant's charging amount(kg) = Room volume(m^3) \times maximum allowable concentration(kg/m^3)

Refrigerant charge(kg)= Additional quantity of refrigerant(kg)+ \sum factory charge for ODU(kg)

Refrigerant charge \leq Maximum refrigerant charge

- (3) When refrigerant's charging amount exceeds the maximum allowable amount, re-design the refrigeration system and divide the refrigeration system to several refrigeration systems with small volume, or adopt corresponding ventilation measures and alarms.

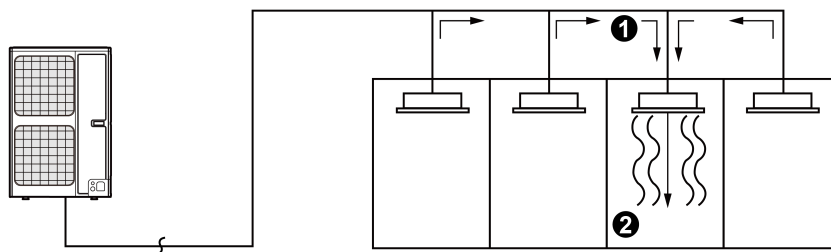

① Flow direction of refrigerant leakage

② Room for refrigerant leakage.

Since the concentration of refrigerant is greater than that of air, pay attention to the spaces where the refrigerant may residue, for example, the basement.

2 Vacuum Pumping, Refrigerant Adding

CAUTION

Do not purge the air with refrigerants but use a vacuum pump to vacuum the installation! There is no extra refrigerant in the outdoor unit for air purging!

2.1 Vacuum Pumping

- (1) Outdoor unit has been charged with refrigerant before delivery. Field-installed connection pipe

needs to be charged with additional refrigerant.

- (2) Confirm whether outdoor liquid and gas valves are closed.
- (3) Use vacuum pump to withdraw the air inside indoor unit and connection pipe from the outdoor valve, as shown in Fig.4.5.1 below.

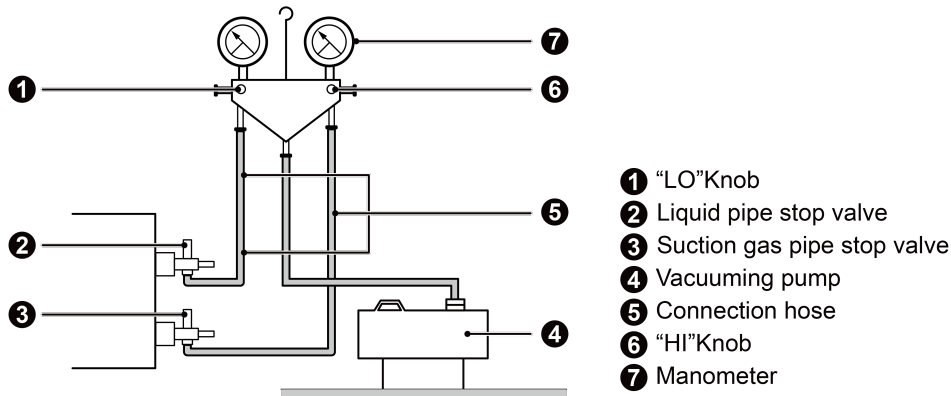

Fig.4.5.1

2.2 Additional Refrigerant Charging

NOTICE

- (1) The amount of refrigerant charged into the system before leaving the factory does not include the amount of refrigerant added to the pipelines and the outdoor unit.
- (2) The additional amount of refrigerant added to the pipelines is determined according to the size of the liquid pipe and its length on site.
- (3) Record the amount of refrigerant added to facilitate after-sales maintenance.

① Additional refrigerant charge R = pipeline additional refrigerant charge A + outdoor unit additional refrigerant charge B

② Calculation of pipeline additional refrigerant charge A

Pipeline additional refrigerant charge A = liquid pipe length (Σ) × additional refrigerant charge per meter of the liquid pipe.

X1: The length of liquid pipe Φ6.35mm(Φ1/4 inch);

X2: The length of liquid pipe Φ9.52mm(Φ3/8 inch);

The length of X1+X2	The length of X2	Quantity additional refrigerant charge per meter of the liquid pipe A
≤20m(65-5/8feet)	≤20m(65-5/8feet)	0
>20m(65-5/8feet)	≥20m(65-5/8feet)	(X2-20)×0.054+X1×0.022 kg (X2-20)×0.036+X1×0.015 LBS
	<20m(65-5/8feet)	(X1+X2-20)×0.022 kg (X1+X2- 65-5/8)×0.015 LBS

③ Calculation of outdoor unit additional refrigerant charge B(kg(LBS))

Indoor Unit Quantity	Outdoor Unit Capacity(kBtu/h)		
	36	48	60
≤2	0	0	0
3	0.3(0.66)	0.3(0.66)	0.5(1.10)
4	0.6(1.32)	0.6(1.32)	0.6(1.32)
≥5	0.6(1.32)	0.6(1.32)	1.0(2.20)

NOTE:

The maximum refrigerant charging volume for the system can't exceed 16.5LBS (including the refrigerant charged in the factory).

Record the amount of refrigerant added to facilitate after-sales maintenance. After ensuring that the system does not leak and the compressor is not working, first charge the specified amount of R410A into the unit from the injection port of the outdoor unit liquid pipe valve until the required amount is reached. If the amount of refrigerant that needs to be added cannot be filled quickly due to pressure rise in the pipe, then power on the unit in cooling mode and charge the refrigerant through the gas valve of the outdoor unit.

For example:

The ODU is composed of the module: 60 kBtu/h.

The IDUs are made up of 4 sets of 15 kBtu/h.

X1=30m(98feet), X2=15m(49feet)

The pipeline additional refrigerant charge A $= (30+15-20) \times 0.022 = 0.55\text{kg}$

$(98+49-65-5/8) \times 0.015 = 1.22\text{LBS}$

outdoor unit additional refrigerant charge B=0.6kg(1.32LBS)

Total Additional refrigerant charge R $= 0.55+0.6=1.15\text{kg}$ (1.22+1.32=2.54LBS).

2.3 Engineering Installation Information Confirmation

Calculate the additional refrigerant quantity according to the method in section 2.2, and record the additional refrigerant quantity and related engineering pipe length information in the engineering installation information confirmation table.

INFORMATION CONFIRMATION TABLE FOR ENGINEERING INSTALLATION		
Length and height of connection pipe	The length from the outdoor unit to the first branch	ft.
	The length from the first branch to the farthest indoor unit	ft.
	Location of outdoor unit	<input type="checkbox"/> upper side/ <input type="checkbox"/> middle/ <input type="checkbox"/> lower side
	The maximum height from the indoor unit to the outdoor unit (outdoor unit is above indoor unit/outdoor unit is under the indoor unit)	/ ft.
Refrigerant additional information	The length of pipe $\Phi 1/4$ inch/The length of pipe $\Phi 3/8$ inch	ft.
	Additional refrigerant volume A for the pipe/Additional refrigerant charge volume B for the outdoor unit	/ LBS.
	Total additional refrigerant volume A+B	/ LBS.
Installation completion date/Commissioning completion date		/
1.Length and height of connection pipes can't exceed the range indicated in the instruction manual. 2.The maximum refrigerant charging volume for the system can't exceed 16.5LBS (including the refrigerant charged in the factory). 3.When this table is filled, please stick it at the inner surface of side plate of the unit for checking during maintenance.		

3 Inspection of Key Parts

3.1 Power

Specifications	Description	
<p>The power supplies of the compressor and fan comprise the following three parts:</p> <p>① The specifications of the input power are 208/230V ~ 60Hz and earth line.</p> <p>② The main control board can convert AC power to DC power,also can convert DC power to three phase AC power.</p> <p>③The circuit breaker and the shunt release are one of the protectors of the main circuit.</p>	<p>Use of power to the main control board:</p> <p>① Providing AC power for the solenoid valve coil and 4-way valve coil.</p> <p>② Generating the low-voltage DC power.</p>	
Circuit diagram	Layout of electrical appliance box	Physical position
Models: GMV-V36WL/C-T(U)、GMV-V48WL/C-T(U)、GMV-V60WL/C-T(U)		

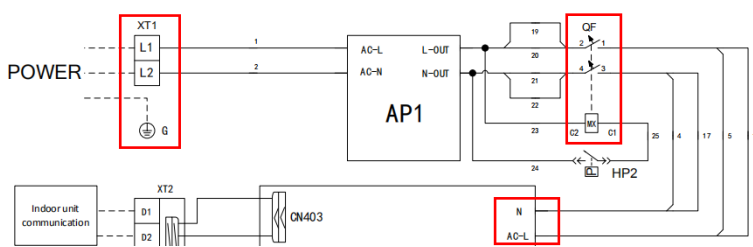
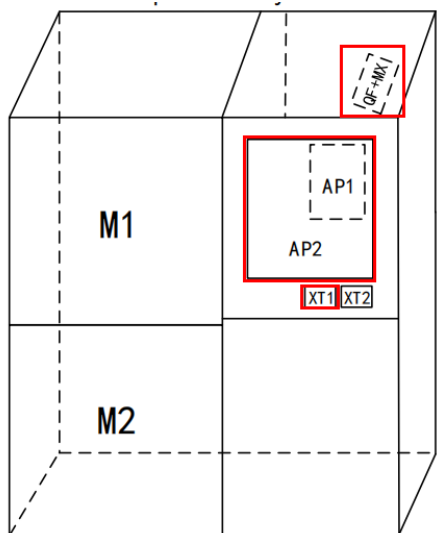
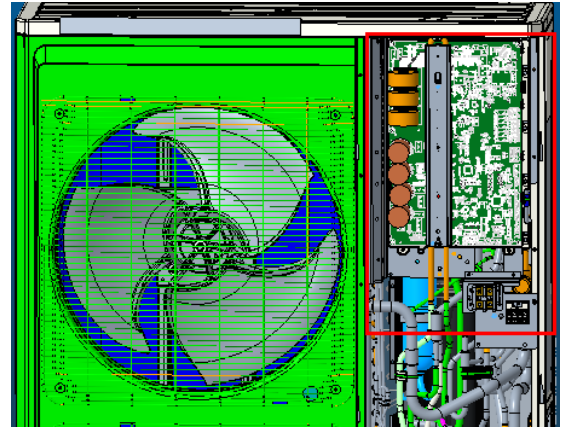
Specifications	Description	
<p>The power supplies of the compressor and fan comprise the following three parts:</p> <ol style="list-style-type: none"> ① The specifications of the input power are 208/230V ~ 60Hz and earth line. ② The main control board can convert AC power to DC power,also can convert DC power to three phase AC power. ③The circuit breaker and the shunt release are one of the protectors of the main circuit. 	<p>Use of power to the main control board:</p> <ol style="list-style-type: none"> ① Providing AC power for the solenoid valve coil and 4-way valve coil. ② Generating the low-voltage DC power. 	
Circuit diagram	Layout of electrical appliance box	Physical position
 <p>The circuit diagram illustrates the power supply system. It starts with a three-phase power input (L1, L2, G) connected to terminal XT1. The power then flows through a main control board (AP1) which has AC-L and AC-N inputs and L-OUT and N-OUT outputs. A circuit breaker (QF) is connected to the L-OUT line, and a shunt release (HP2) is connected to the N-OUT line. The system also includes indoor unit communication components (XT2, D1, D2) and a transformer (QN403). Various terminals (19, 20, 21, 22, 23, 24, 25, 4, 17, 5, 18) are shown for connection to other components.</p>	 <p>The 3D layout diagram shows the internal arrangement of the electrical appliance box. It is divided into two main sections, M1 and M2. Component M1 is located in the upper right area, and M2 is in the lower left. The main control board (AP1) and a secondary component (AP2) are positioned in the center-right. Terminals XT1 and XT2 are located at the bottom right. A component labeled [QF+HP2] is shown in the top right corner.</p>	 <p>The photograph shows the physical unit with its front panel removed. A large green fan is visible on the left side. On the right side, the internal electrical components, including the main control board (AP1) and other modules, are visible. A red box highlights the area where the main control board and other components are located, corresponding to the layout diagram.</p>

3.1.1 Mechanical Inspection

- (1) Confirm that the unit power is disconnected.
- (2) Remove the electrical appliance cover.
- (3) Check whether the power cable is fixed on the wiring board.
- (4) Check whether the fuses on the main board and filter board are damaged.
- (5) Check whether the varistors on the main board and filter board are damaged.

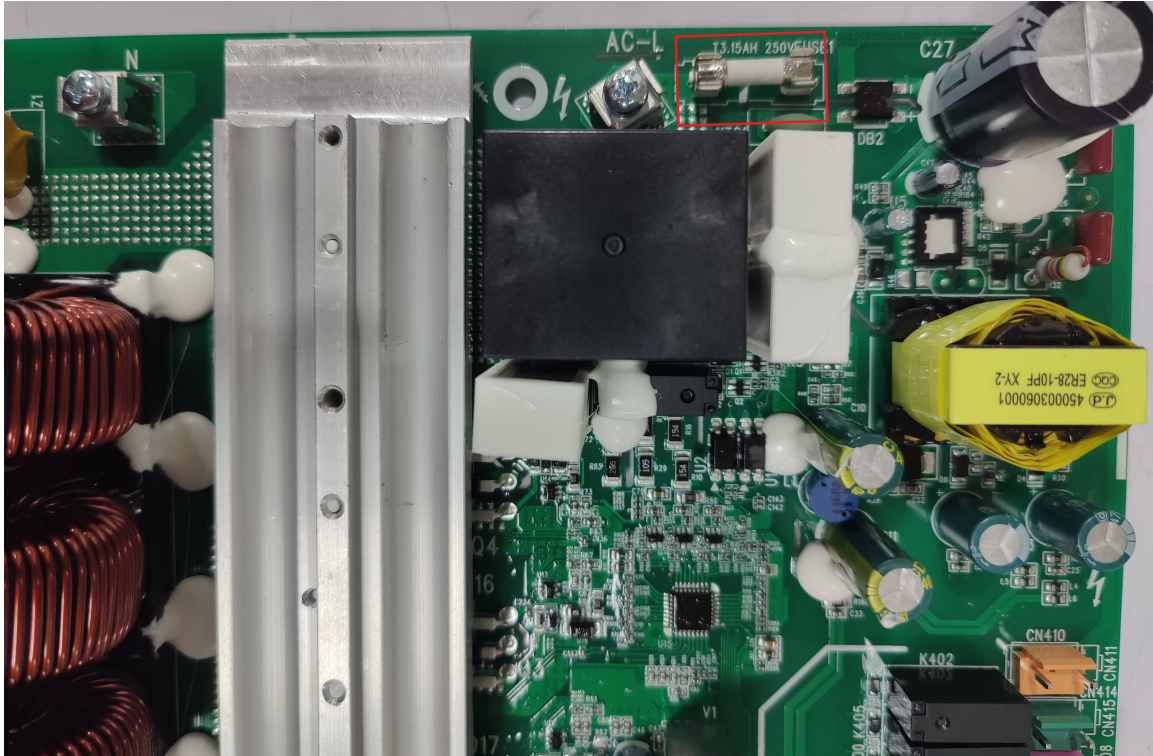

3.1.2 Electrical Inspection

Check the power cable from the main switch board to the ODU:

- (1) Use an ohmmeter of at least 500V DC to check whether the insulation resistance between each phase and the ground reaches at least 1 megohm. Small insulation resistance indicates a potential electric leakage.

Warning: Electric shock

- (2) After the checking, connect the power and verify that the voltage of the power terminals is correct:
Voltage between N and AC-L: 208/230 VAC.

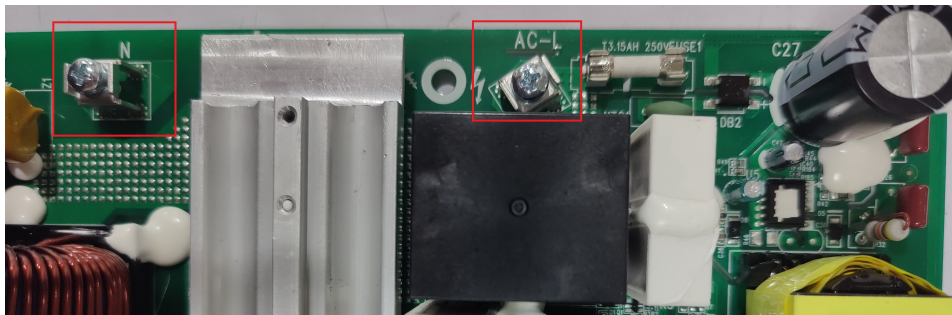

3.2 Temperature Sensors

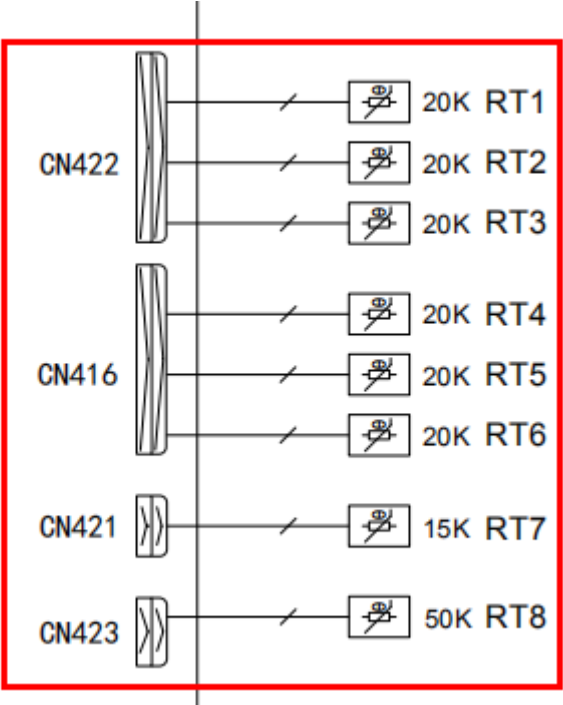
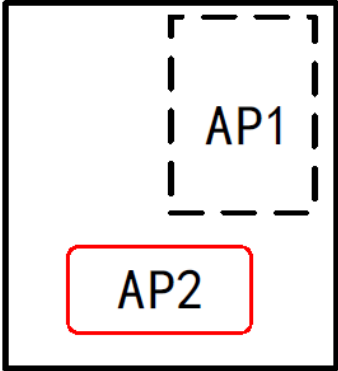
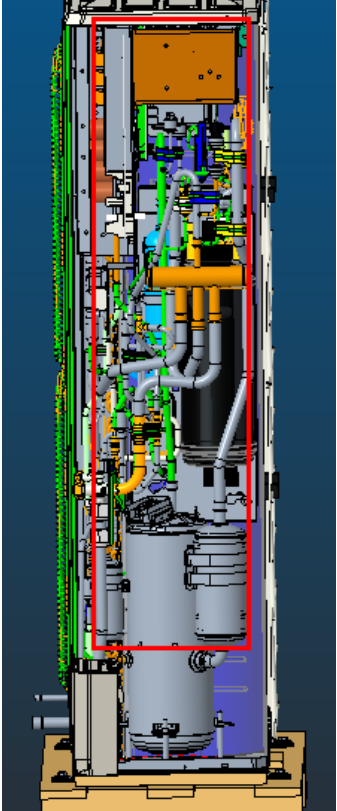
Specifications	Description	
Three types of temperature sensors of different specifications are used, including 50K, 20K and 15K.	The sensors are used to measure the temperature of the unit at different positions.	
Models: GMV-V36WL/C-T(U)、GMV-V48WL/C-T(U)、GMV-V60WL/C-T(U)		
Circuit diagram	Layout of electrical appliance box	Physical position
		

3.2.1 Mechanical Inspection

- (1) Confirm that the unit Power is disconnected.
- (2) Find the place corresponding to each sensor on the unit and check if the sensors are firmly fixed on the unit.

3.2.2 Electrical Inspection

Measure the actual temperature and resistance of the temperature sensors, and compare it with the characteristic curve of the temperature sensors to determine whether the thermocouple is normal.

- (1) Power off the unit. Remove the electrical appliance cover after the ODU stops.

Warning: Electric shock

- (2) Remove the electrical appliance cover and check whether the connecting terminal of the temperature sensors is firm.
- (3) Use a thermometer to measure the temperature of the spot sensed by the temperature sensors.
- (4) Disconnect the connecting terminal of the corresponding temperature sensor from the main board. Use a multimeter to measure the resistance of the temperature sensors and compare it with the confirmed temperature range.
- (5) If the measured resistance and temperature do not match with the resistance and temperature in the characteristic curve of the temperature sensor, the temperature sensor needs to be replaced.
- (6) If the measured resistance and temperature match with the resistance and temperature in the characteristic curve of the temperature sensor, but the temperature of the spot is abnormal according to the monitoring of the unit, the main board needs to be replaced.

15K temperature sensor resistance - temperature curve

15K	
Temperatur e\°C	Resistanc e\KΩ
-20	144
-15	108.7
-10	82.75
-5	63.46
0	49.02
5	38.15
10	29.9
15	23.6
20	18.75
25	15
30	12.07
35	9.779
40	7.967
45	6.529
50	5.379
55	4.456
60	3.711
65	3.105
70	2.611
75	2.205
80	1.871
85	1.594
90	1.363
95	1.171
100	1.009
105	0.873
110	0.7577
115	0.6599
120	0.5765
125	0.5052
130	0.4441
135	0.3914
140	0.346
145	0.3066
150	0.2725
155	0.2427
160	0.2166

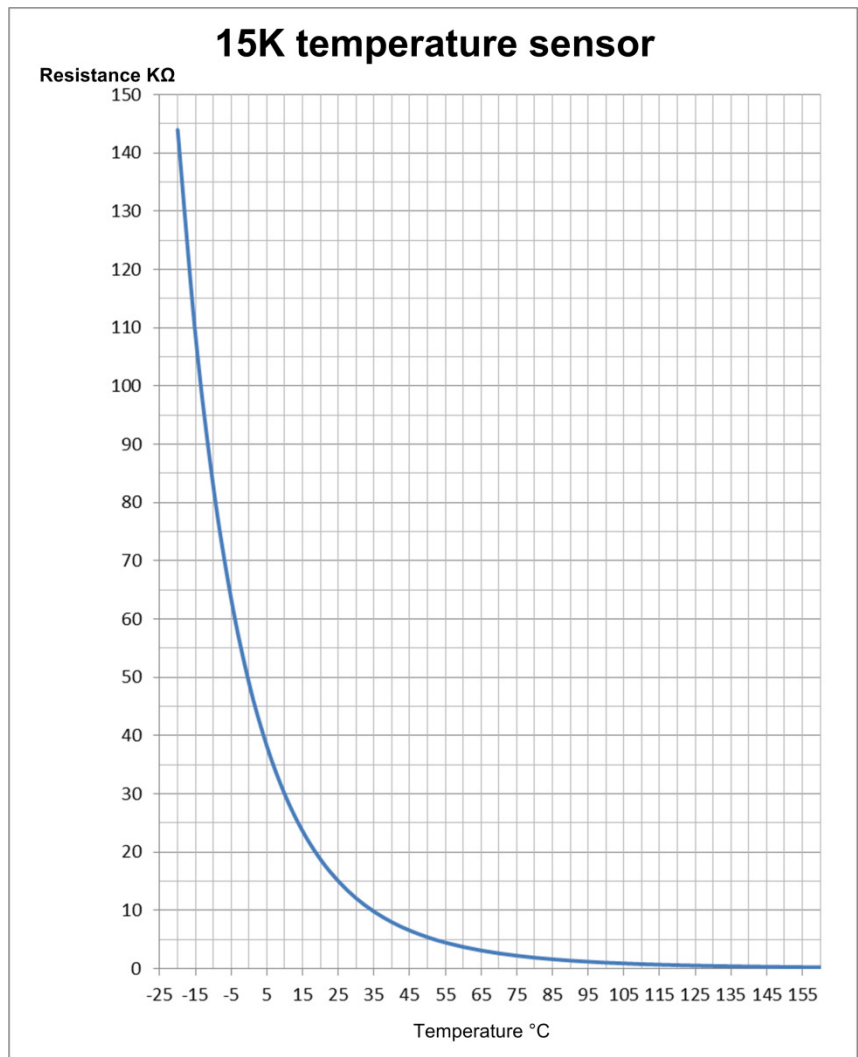

20K temperature sensor resistance - temperature curve

20K	
Temperature °C	Resistance KΩ
-30	361.8
-25	265.5
-20	196.9
-15	145
-10	110.3
-5	84.61
0	65.37
5	50.87
10	39.87
15	31.47
20	25.01
25	20
30	16.1
35	13.04
40	10.62
45	8.705
50	7.173
55	5.942
60	4.948
65	4.14
70	3.481
75	2.94
80	2.495
85	2.125
90	1.818
95	1.561
100	1.346
105	1.164
110	1.01
115	0.8799
120	0.7687
125	0.6736
130	0.5921
135	0.5219
140	0.4613
145	0.4088
150	0.3633
155	0.3237
160	0.2891

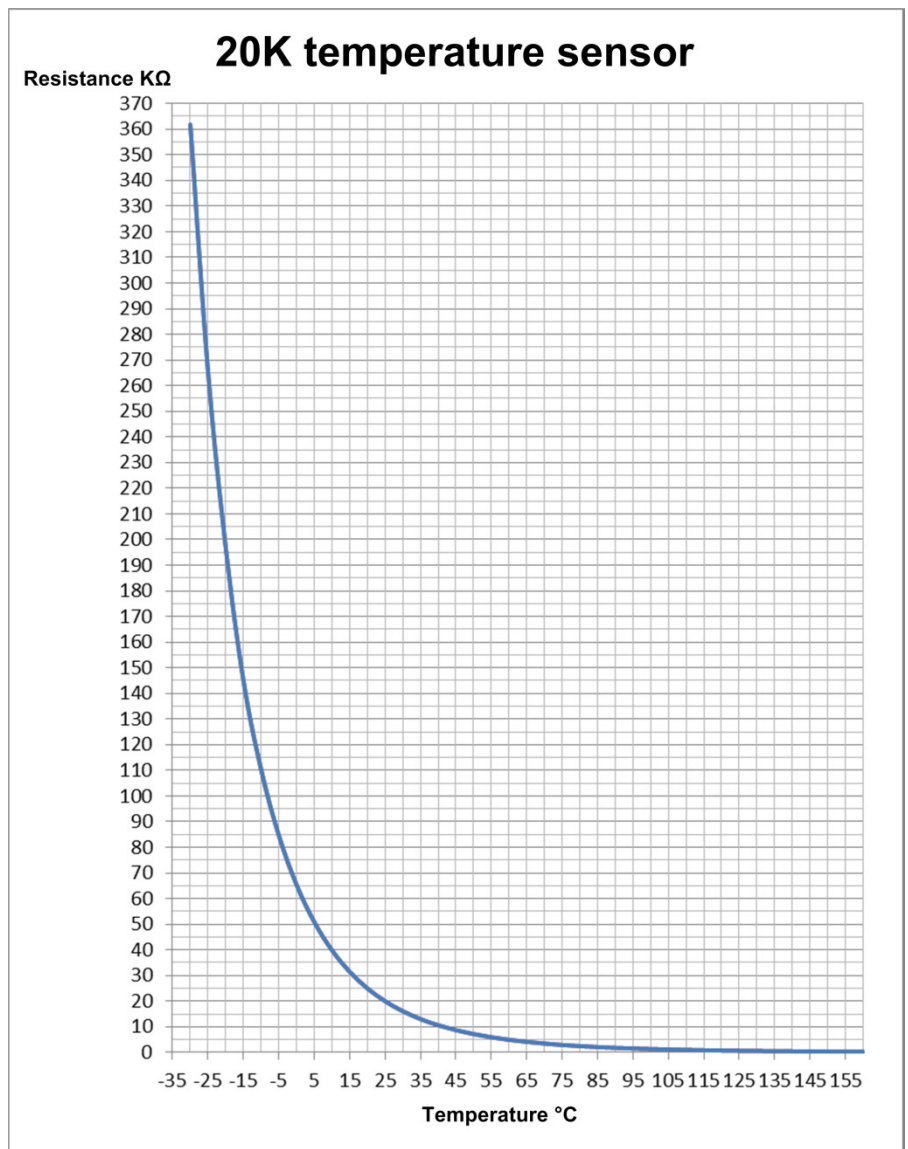

50K temperature sensor resistance - temperature curve

50K	
Temperature °C	Resistance kΩ
-30	911.56
-25	660.93
-20	486.55
-15	362.99
-10	274.02
-5	209.05
0	161.02
5	126.17
10	98.006
15	77.349
20	61.478
25	49.191
30	39.61
35	32.088
40	26.147
45	21.425
50	17.651
55	14.618
60	12.168
65	10.178
70	8.5551
75	7.2245
80	6.1288
85	5.2223
90	4.4693
95	3.841
100	3.3147
105	2.8721
110	2.4983
115	2.1816
120	1.9123
125	1.6821
130	1.485
135	1.3155
140	1.1694
145	1.0429
150	0.9331

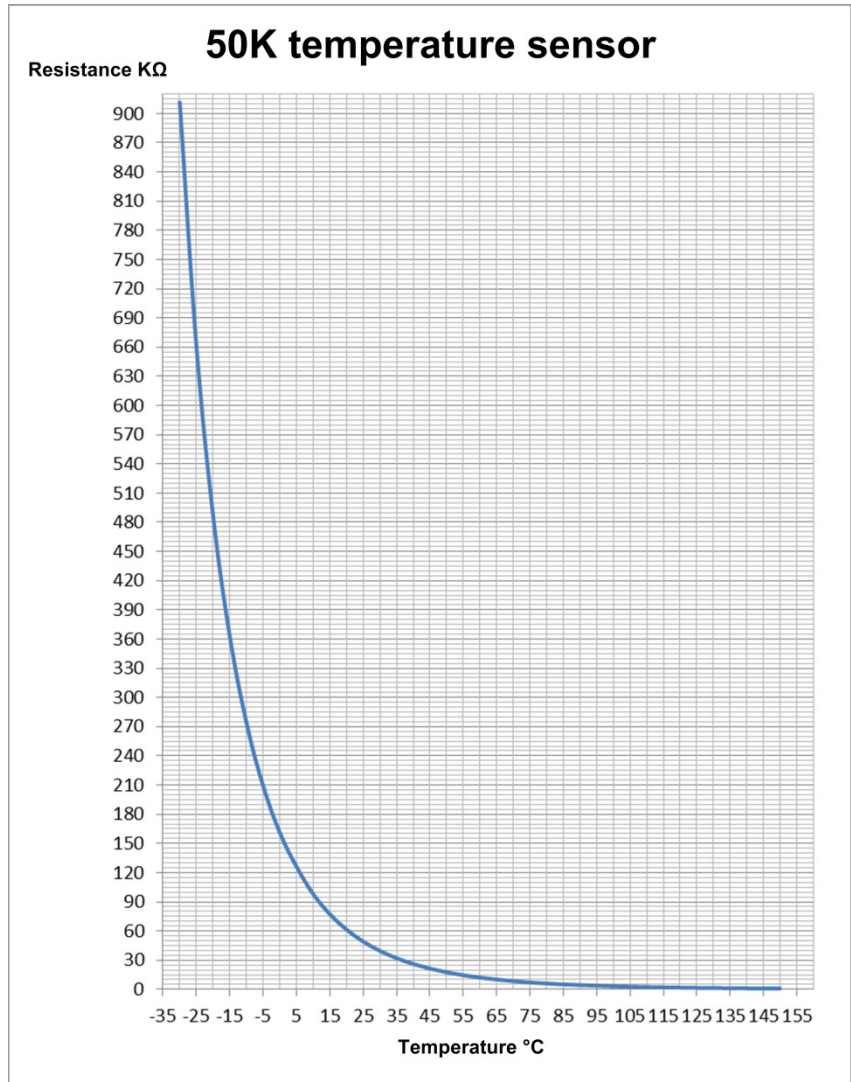

3.3 Solenoid Valve

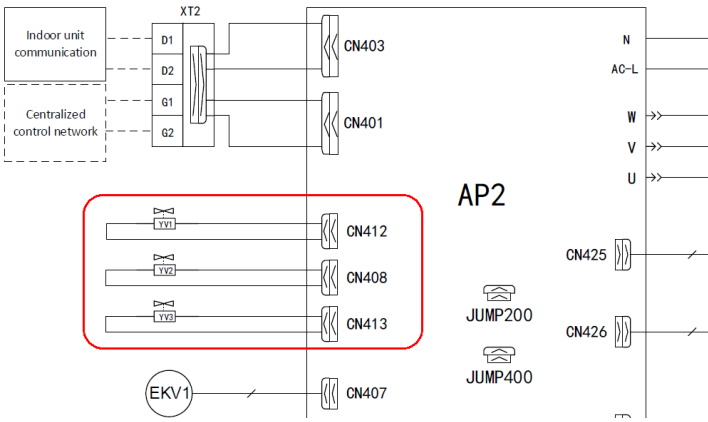
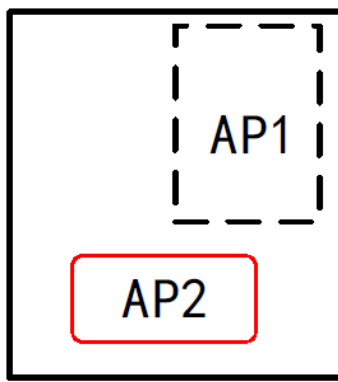
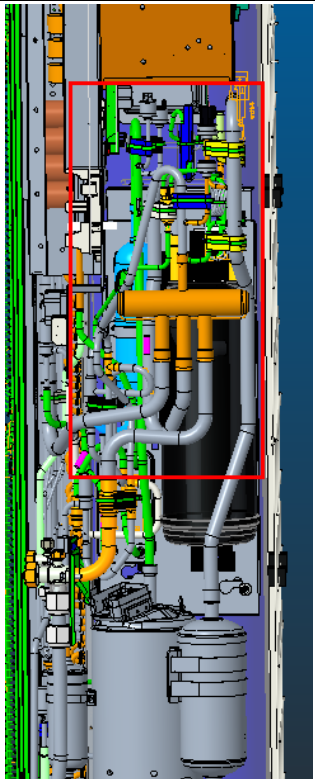
Specifications	Description	
<p>Coils of different types are used on:</p> <ul style="list-style-type: none"> ① 4-way valve ② Solenoid valve. 	<ul style="list-style-type: none"> ① The 4-way valve is used to switch between cooling mode and heating mode. If the 4-way valve is active, the unit works in heating mode, if the 4-way valve is inactive, the unit works in cooling mode. ② The solenoid valve is used to control the on-and-off of the pipeline. The valve of the unit is solid closed. That is, the valve is closed when it is inactive, open when it is active. 	
Circuit diagram	Layout of electrical appliance box	Physical position
Models: GMV-V36WL/C-T(U)、GMV-V48WL/C-T(U)、GMV-V60WL/C-T(U)		
 <p>The diagram shows a terminal block labeled AP2 with terminals CN403, CN401, CN412, CN408, CN413, and CN407. It also shows connections for indoor unit communication (D1, D2) and centralized control network (G1, G2) through terminal block XT2. A red box highlights the solenoid valve coils (CN412, CN408, CN413). Other components include EKV1, JUMP200, and JUMP400.</p>	 <p>The diagram shows a rectangular layout of the electrical appliance box. A dashed box labeled AP1 is positioned at the top, and a solid red box labeled AP2 is positioned at the bottom.</p>	 <p>The 3D cutaway view shows the internal components of the indoor unit. A red box highlights the solenoid valve assembly, which is located in the upper-middle section of the unit, connected to various pipes and electrical components.</p>

3.3.1 Mechanical Inspection

- (1) Confirm that the unit Power is disconnected.
- (2) Find the 4-way valve or solenoid valve, check whether the fixing screw is loose and whether the valve and coil have any apparent exceptions.

3.3.2 Electrical Inspection

Compare the measured coil resistance with the normal coil resistance to check whether the coil is damaged.

- (1) Power off the unit. Remove the electrical appliance cover after the ODU stops.

Warning: Electric shock

- (2) Remove the electrical appliance cover and check whether the connecting terminal of the 4-way valve or solenoid valve is firm.
- (3) Disconnect the corresponding valve's coil terminal from the main board and use a multimeter to measure the coil resistance.
- (4) If the measured resistance does not match with that in the following table, the coil needs to be replaced.

Coil	Bolt on the main board	Resistance (Ω)	Normal range of deviation
4-way valve	CN412	1880	$\pm 10\%$
Subcooler solenoid valve	CN408	1830	$\pm 10\%$
Sub oil return solenoid valve	CN413	1830	$\pm 10\%$

3.4 Electronic Expansion Valve

Specifications		Description	
The electronic expansion valve with the largest openness of 480 pls and 5-core coil.		The electronic expansion valve is used to control the flow. When the electronic expansion valve is closed (the openness is 0 pls), the flow is stopped.	
Circuit diagram	Layout of electrical appliance box	Physical position	
Models: GMV-V36WL/C-T(U), GMV-V48WL/C-T(U), GMV-V60WL/C-T(U)			

3.4.1 Mechanical Inspection

Step 1: Switch off the power of the ODU.

Step 2: Check whether the coil of the electronic expansion valve is firmly fixed on the electronic expansion valve.

3.4.2 Electrical Inspection

Step 1: Power off the ODU and power on it. When the ODU is powered on again, the electronic expansion valve should be reset. When the electronic expansion valve is reset, touch the valve with a hand to check if the valve core rotates. In the second half of the resetting process, the valve core will click and vibrate obviously; otherwise, the electronic expansion valve, coil or the main board needs to be replaced.

Step 2: Switch off the power of the ODU, disconnect the coil terminal of the electronic expansion valve from the main board and use a multimeter to measure the resistance of each contact point of the terminal. The normal range of the resistance is shown in the following table. If any value is beyond the normal range, the coil is damaged and needs to be replaced.

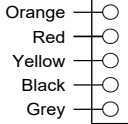
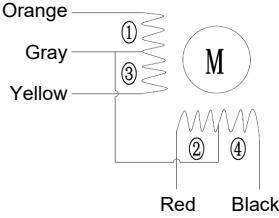
Coil	Interface No.	Color	Port specifications	Max. number of steps	Terminal layout	Diagram of internal coils	Coil resistance range
Heating electronic expansion valve	CN407	White	5 cores	480			46Ω±3.7Ω
Subcooler electronic expansion valve	CN406	Red	5 cores	480			
Vapor injection electronic expansion valve	CN429	Black	5 cores	480			

3.5 Fans

Specifications		Description	
<p>The unit is equipped with two fans. The fans are connected to the main control board.</p>		<p>The fans are powered by a DC inverter motor and can adjust the speed automatically according to the environmental temperature and load, thus adapting to the demand of the unit operation.</p>	
Circuit diagram	Layout of electrical appliance box	Physical position	
Models: GMV-V36WL/C-T(U)、GMV-V48WL/C-T(U)、GMV-V60WL/C-T(U)			

3.5.1 Mechanical Inspection

Step 1: Switch off the power of the ODU.

Step 2: Check whether the connector between the fan motor and fan drive board is firmly connected.

Step 3: Rotate the blades with a hand to check whether they can rotate smoothly and whether the blades rub the baffle ring during rotation. If the blades are blocked during rotation, the motor needs to be replaced; if the blades rub the baffle ring during rotation, check whether the blades and baffle ring deform and needs to be replaced.

3.5.2 Electrical Inspection

Switch off the power of the ODU. Disconnect the connector between the fan motor and fan drive board. Use a multimeter to measure the resistance of each contact point of the motor terminal. The normal range of the resistance is shown in the following table. If any value is beyond the normal range, the motor is damaged and needs to be replaced.

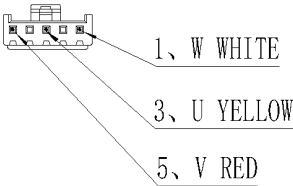
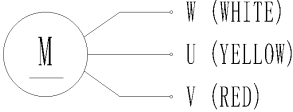
Terminal layout	Diagram of internal coils	Range of coil resistance between any two phases
 <p>1、W WHITE 3、U YELLOW 5、V RED</p>	 <p>W (WHITE) U (YELLOW) V (RED)</p>	<p>37.4Ω±8%</p>

3.6 Compressor

Specifications	Description
Models: QXAT-F400zN450	Compression refrigerant, recycling refrigerant.
Models: GMV-V36WL/C-T(U), GMV-V46WL/C-T(U), GMV-V60WL/C-T(U)	
Circuit diagram	Physical position
<p>The circuit diagram illustrates the electrical connections for the compressor. It shows a power supply (XT1) with terminals L1, L2, and G. The power is connected to a main switch (AP1) with terminals AGL, ACN, L-OUT, and N-OUT. The L-OUT and N-OUT lines are connected to a circuit breaker (QF) and then to the compressor (COMP) through terminals 19, 20, 21, 22, 23, 24, 25, 4, 17, 5, and 18. The compressor is connected to the W, V, and U phases, which are highlighted in a red box. The diagram also shows indoor unit communication (XT2) with terminals D1, D2, G1, and G2, and a centralized control network with terminals G1 and G2. Other components include CN403, CN401, CN412, CN408, CN413, EKV1, CN407, EKV2, CN406, CN425, JUMP200, CN426, JUMP400, SP1, SP2, and CN417. The compressor is labeled COMP 3.</p>	<p>The physical position diagram shows the internal components of the VRF unit. The compressor is located at the bottom right of the unit, connected to the fan assembly. The fan assembly consists of two fans and a control board. The compressor is connected to the W, V, and U phases, which are highlighted in a red box. The diagram also shows the indoor unit communication and centralized control network connections.</p>

3.6.1 Diagnosis of Compressor Failures

3.6.1.1 When the unit can be started

Step 1:

If the unit can be started, check the faulty compressor's line current. Use a pressure gauge to measure the gas and liquid valve pressure and monitor the measured data on a PC. Compare the data to the following table of recommended current. The current may deviates by about 10% depending on the inverter compressor's speed and working condition.

When the compressor frequency is 30 Hz, the current curve under different evaporation temperature and condensation temperature is shown as follows:

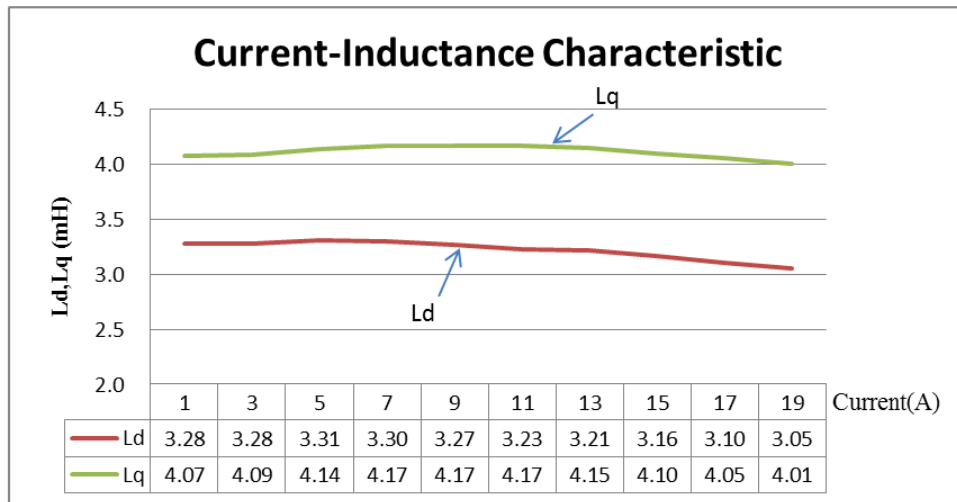

NOTE!

When the compressor is working at another frequency, the current curve can be obtained through interpolation calculation of the above frequency.

NOTE!

When the compressor is working at another frequency, the current curve can be obtained through interpolation calculation of the above frequency.

Step 2:

Check whether the running sound of the compressor is normal and whether any high-pitched sound or obvious scratch can be heard. If there is a nearby unit running properly, compare the sound of the compressor under inspection with that of the normally running unit.

Step 3:

Check whether the electronic expansion valve of the ODU and 4-way valve work properly, and whether the oil-return pipeline and oil-return valve are normal. Touch the oil-return capillary tube with a hand to check whether oil flows in the tube and check the pipeline temperature.

Diagnosis method:

- 1) Electronic expansion valve: When the unit is powered on and off each time, the electronic expansion valve needs to reset. Touch the valve with a hand to check if the valve core rotates. In the second half of the resetting process, the valve core will click and vibrate obviously.

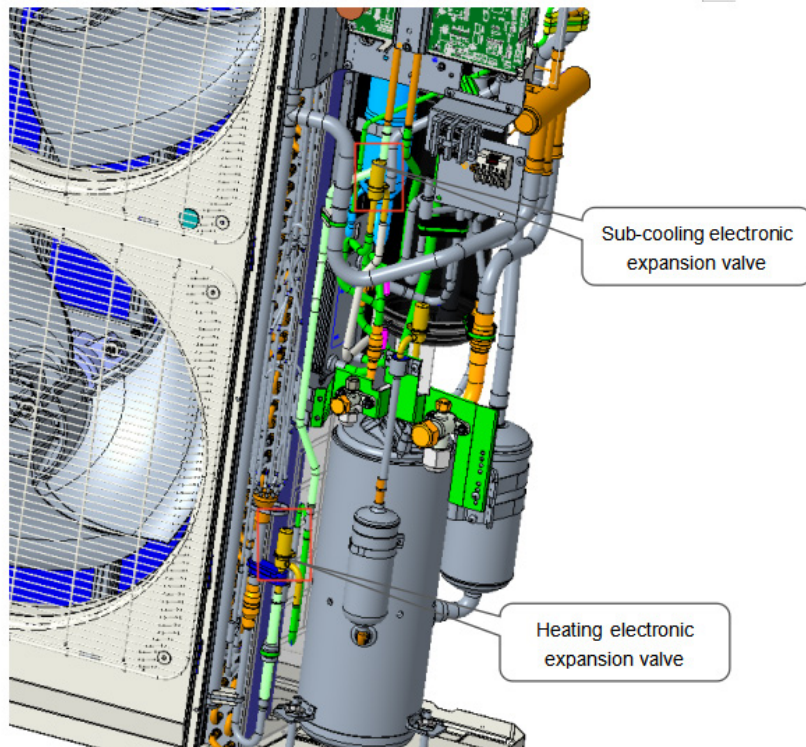

Note on touching the electronic expansion valve:



Notes:

- ① Check whether the coil is firmly fixed.
- ② Touch the upper part of the electronic expansion valve and check whether the resetting of the unit can be clearly felt.

- 2) 4-way valve: When it is normal, the temperature different between it and the four copper tubes connecting to the valve is obvious. When the 4-way valve works, obvious sound and vibration can be heard and felt.

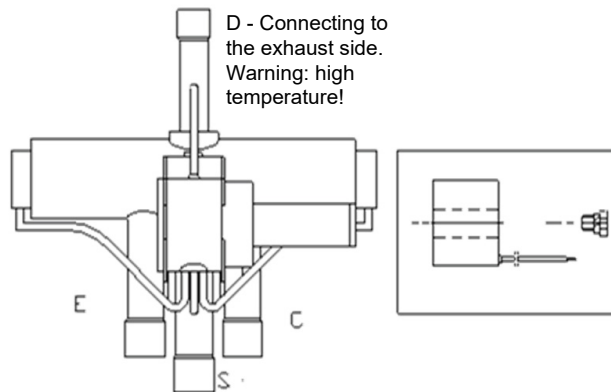
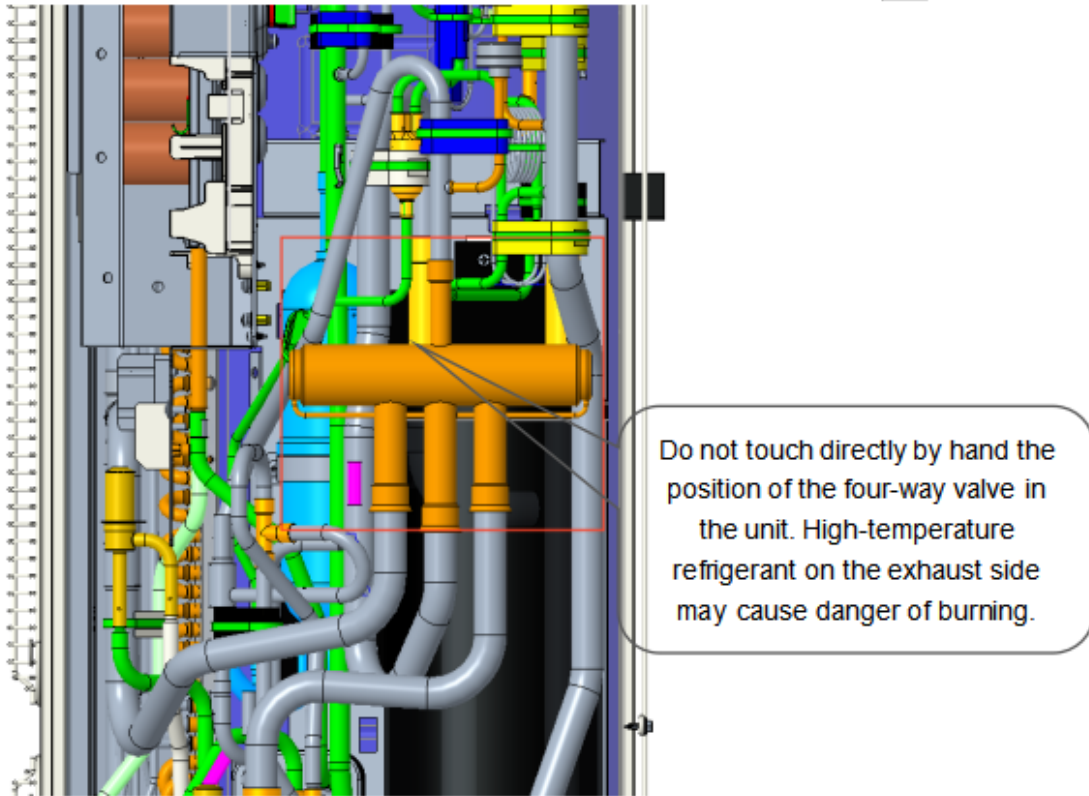

Marks are made on the 4-way valve: D indicates connection to the exhaust side, E indicates connection to the IDU evaporator, S indicates connection to the air inlet of gas-liquid separator, C indicates connection to the condenser; when the system runs in the cooling mode, C indicates that the pipeline is in the high-pressure and high-temperature status, while E and S indicate that the pipeline is in the low-pressure and low-temperature status; when the system runs in the heating mode, E indicates that the pipeline is in the high-pressure and high-temperature status, while C and S indicate that the pipeline is in the low-pressure and low-temperature status; the pipe marked by D is connected to the air outlet and remains in the high-pressure and high-temperature status. When the unit is being started, defrosting

and conducting oil return, the 4-way valve produces obvious valve pushing sound. Do not touch the pipeline with hands. Otherwise, you may get scalded.

- 3) Oil-return solenoid valve: It can be diagnosed based on the oil-return valve status displayed on the monitor program and the actual operation. When the balance valve is open, the coil heats up and the lubricant flow before and after the valve is obvious.

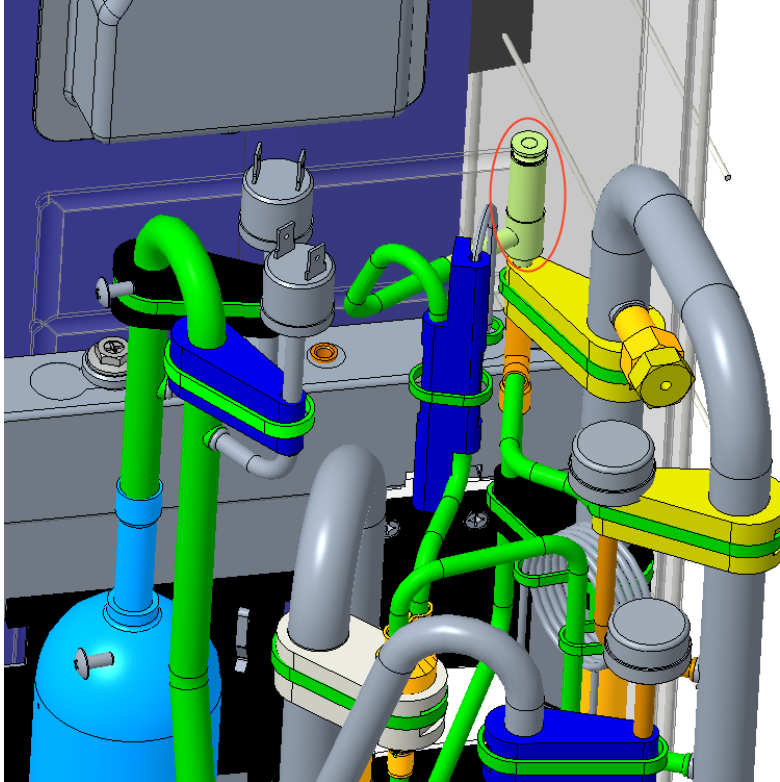

Step 4:

Test the main board (IPM module).

1: Disconnect the power and wait five minutes, and unplug the compressor cable.

2: As shown in the figure, switch the multimeter to the diode gear. Point the black probe to the P bonding pad and the red probe to the N wiring terminal. In the normal condition, the multimeter will not beep. If it does, the main board is damaged and needs to be replaced.

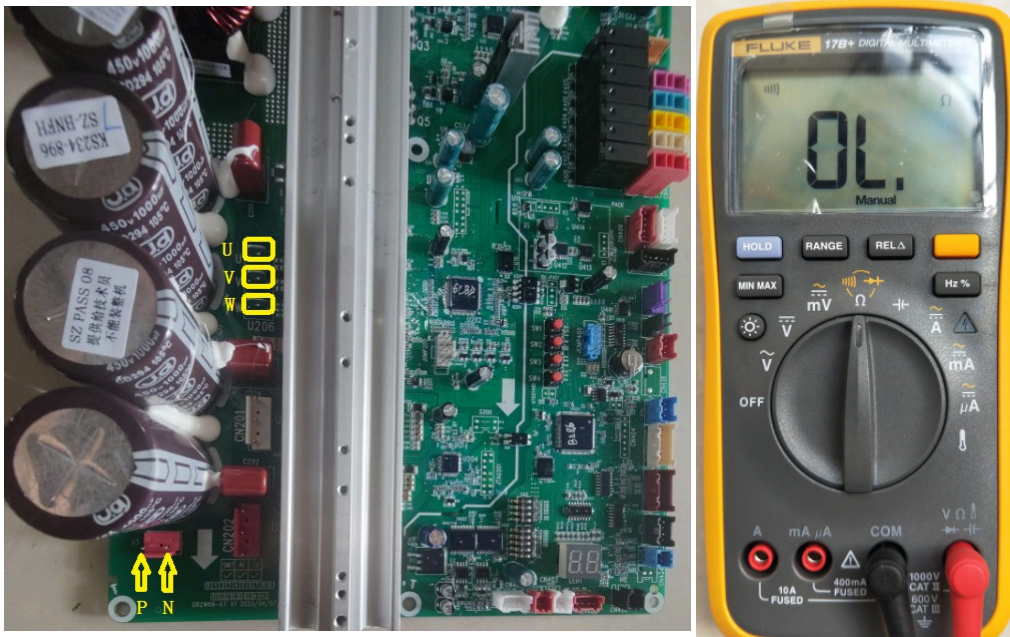

3: Point the black probe to the P needle file and the red probe to the V wiring terminal. In the normal condition, the multimeter will not beep. If it does, the drive board is damaged and needs to be replaced.

4: Point the black probe to the P needle file and the red probe to the W wiring terminal. In the normal condition, the multimeter will not beep. If it does, the drive board is damaged and needs to be replaced.

5: Point the black probe to the U wiring terminal and the red probe to the N needle file. In the normal condition, the multimeter will not beep. If it does, the drive board is damaged and needs to be replaced.

6: Point the black probe to the V wiring terminal and the red probe to N needle file. In the normal condition, the multimeter will not beep. If it does, the drive board is damaged and needs to be replaced.

7: Point the black probe to the W needle file and the red probe to the N needle file. In the normal condition, the multimeter will not beep. If it does, the drive board is damaged and needs to be replaced.

3.6.1.2 When the unit cannot be started properly.

Step 1:

Disconnect the unit from power. Remove the terminal box cover and check whether the compressor is wired correctly.

Step 2:

Measure the resistance between any two of the wiring terminals of the compressor (U, V and W). The resistance between two wiring terminals is $0.197 \pm 7\% \Omega$.



Measure the grounding resistance of each wiring terminal, which should be greater than 10 M Ω ; otherwise, the compressor has an internal fault.

Step 3:

When the unit cannot be started properly, the solenoid valves of the system, including the electronic expansion valve and oil-return valve, need to be checked using the same method described above.

Step 4:

Check the IPM module using the same method described above.

3.7 Board

3.7.1 Main Board

The main board is used to control the load of the ODU.

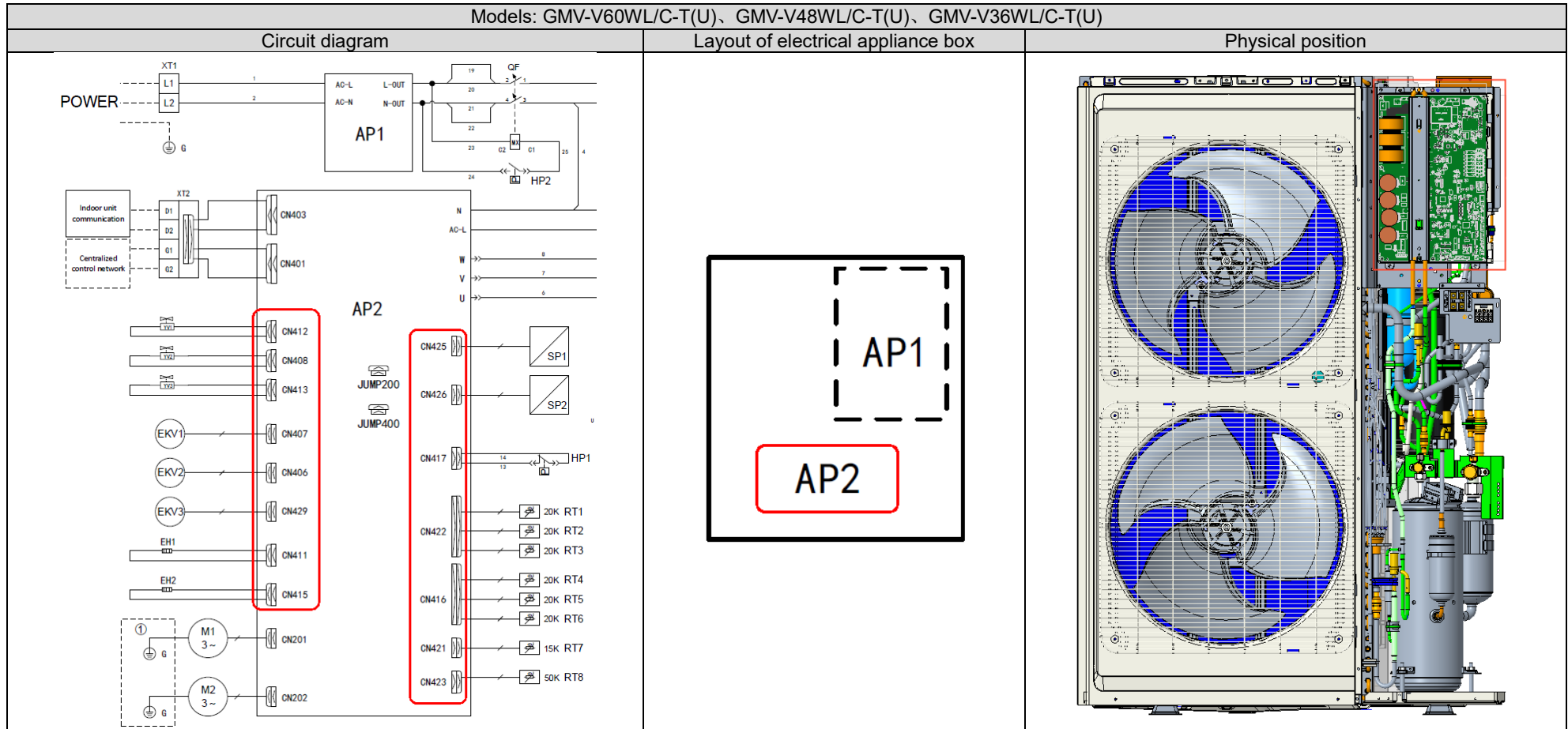

Step 1: Disconnect the power and wait five minutes.

Step 2: As shown in the figure, switch the multimeter to the diode gear. Point the black and red probes to the following positions to check if the main board is normal.

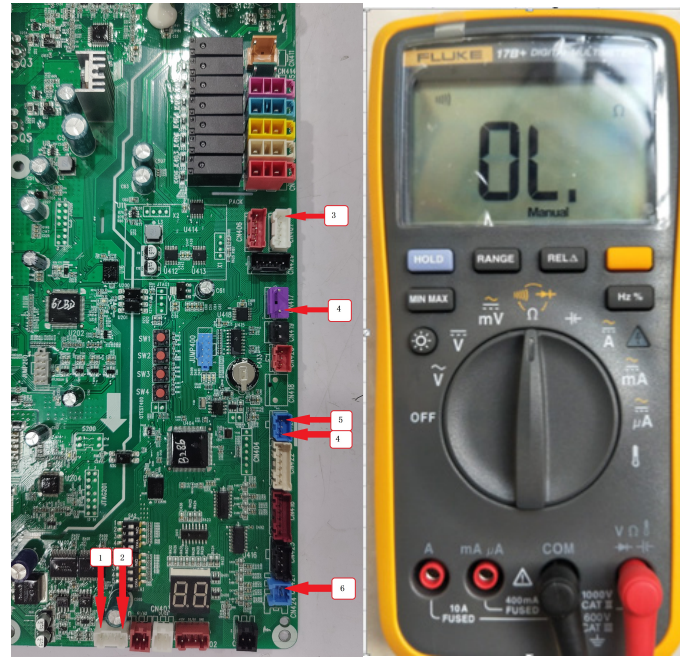

Black probe	Red probe	Symptom
CN400 (1)	CN400 (2)	The main board is normal if the multimeter does not beep.
CN407 (3)	CN417 (4)	The main board is normal if the multimeter does not beep.
CN426(5)	CN417 (4)	The main board is normal if the multimeter does not beep.
CN421 (6)	CN417 (4)	The main board is normal if the multimeter does not beep.
CN407 (3)	CN426 (5)	The main board is normal if the multimeter does not beep.
CN421 (6)	CN426 (5)	The main board is normal if the multimeter does not beep.

3.7.2 Compressor Drive

Specifications		Description
—		This part is used to control the operation of the compressor.
Models: GMV-V60WL/C-T(U)、GMV-V48WL/C-T(U)、GMV-V36WL/C-T(U)		
Circuit diagram	Layout of electrical appliance box	Physical position
<p>The circuit diagram illustrates the electrical connections for the compressor drive. Power is supplied via XT1 (L1, L2, G) to AP1. Indoor unit communication is handled by XT2 (D1, D2, G1, G2) connected to AP2. The diagram shows connections for various components including switches (SP1, SP2), relays (HP1, HP2), resistors (RT1-RT8), and motors (M1, M2). A red box highlights the AC-L, AC-N, W, and V terminals on AP2.</p>	<p>The layout of the electrical appliance box shows the physical locations of AP1 and AP2. AP1 is located in the upper right area, and AP2 is located in the lower left area. Both are enclosed in dashed boxes.</p>	<p>The physical position of the compressor drive board is shown within the indoor unit chassis. The board is located at the top right, adjacent to the fans and other components. A red box highlights the board's location.</p>

- (1) Before the inspection: Find a correct digital multimeter and switch it to the diode gear. Power off the unit and wait two minutes. Disconnect the U, V and W cables of the compressor and N and AC-L power cables from the main board. Do not operate without waiting two minutes after the unit is powered off.
- (2) Testing method:
 - ① Point the black probe of the multimeter to the P needle file shown in the following figure and the red probe to U, V and W wiring terminals respectively and check the readings of the multimeter;
 - ② Point the red probe of the multimeter to the N needle file shown in the following figure and the black probe to U, V and W wiring terminal respectively and check the readings of the multimeter.
- (3) Result analysis: If all the readings of the multimeter are between 0.3 V and 0.7 V in the above 12 conditions, the module is normal; if any of the readings is 0, the module is damaged.

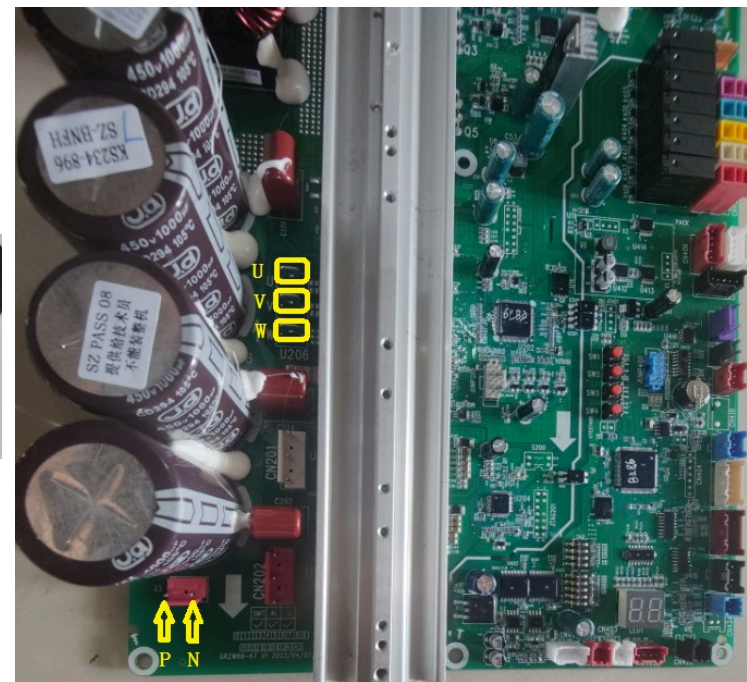
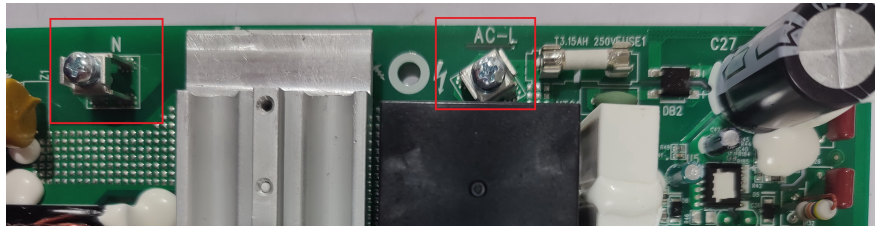

3.7.3 Fan Drive

Specifications		Description
—		This part is used to control the operation of the fan.
Models: GMV-V60WL/C-T(U), GMV-V48WL/C-T(U), GMV-V36WL/C-T(U)		
Circuit diagram	Layout of electrical appliance box	Physical position

1. Upper Fan Inspection

(1) Before the inspection: Find a correct digital multimeter and switch it to the diode gear. Power off the unit and wait two minutes. Disconnect the U1, V1 and W1 cables of the fans from the drive board. Do not operate without waiting two minutes after the unit is powered off.

(2) Testing method: Point the black probe of the multimeter to the P needle file shown in the following figure and the red probe to U1, V1 and W1 wiring terminals respectively and check the readings of the multimeter; point the red probe of the multimeter to the N needle file shown in the following figure and the black probe to U1, V1 and W1 wiring terminal respectively and check the readings of the multimeter.

(3) Result analysis: If all the readings of the multimeter are between 0.3 V and 0.7 V in the above six conditions, the module is normal; if any of the readings is 0, the module is damaged.

2. Under Fan Inspection in a similar way

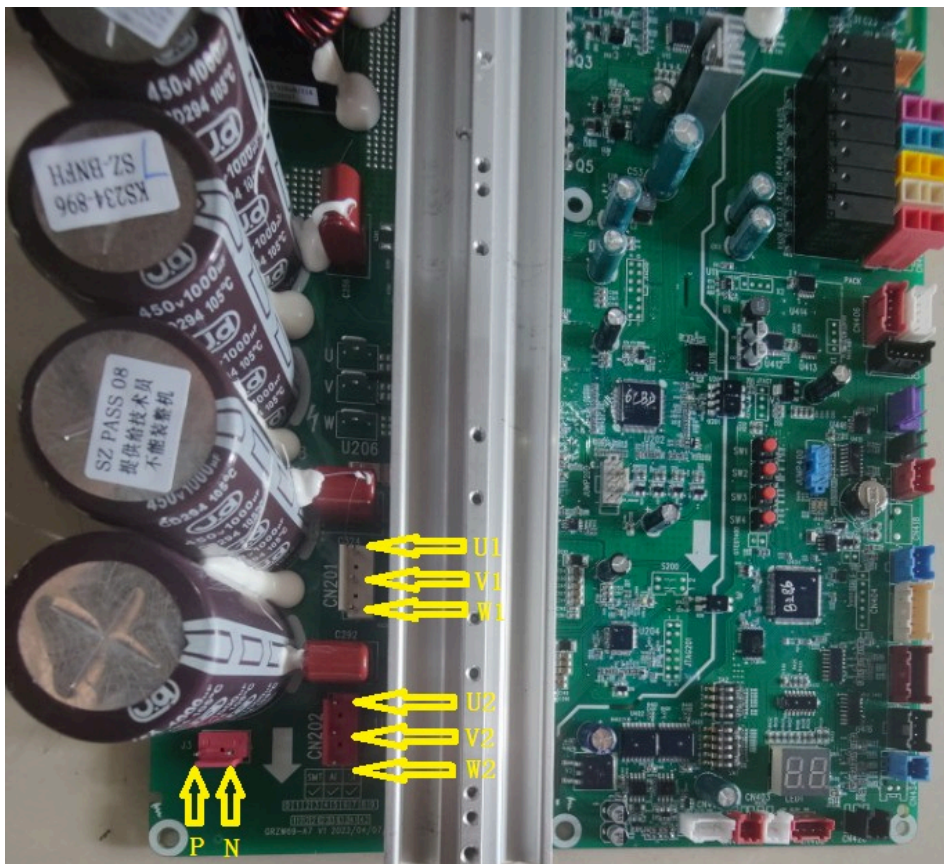

3.8 Pressure Sensor

Specifications		Description
—		Inspection of high-pressure temperature of the high-pressure sensor: <ol style="list-style-type: none"> 1. Control of compressor output capacity 2. Conversion and calculation of saturated condensing temperature 3. Protection high pressure 4. Inspection of high-pressure value and calculation of exhaust superheat degree 5. Inspection of the minimum and maximum compression ratio Inspection of low-pressure temperature of the low-pressure sensor: <ol style="list-style-type: none"> 1. Control of compressor output capacity 2. Conversion and calculation of saturated evaporating temperature 3. Inspection of suction superheat degree 4. Low-pressure protection functions 5. Inspection of the minimum and maximum compression ratio
Models: GMV-V60WL/C-T(U)、GMV-V48WL/C-T(U)、GMV-V36WL/C-T(U)		
Circuit diagram	Layout of electrical appliance box	Physical position

Inspection procedure

1. Preparations
 - (1) Use the wired controller or remote controller to shut down the unit.
 - (2) Remove the front cover and open the electrical appliance box.
2. Inspection of low-pressure sensor
 - (1) Connect the pressure gauge to the gas valve and check if the gas and liquid valves are open.
 - (2) Switch the unit to the cooling mode. After the system stabilizes, check the reading of the pressure gauge.
 - (3) Check the unit's suction pressure via the wired controller and compare it with the reading of the pressure gauge on the gas valve. If the value shown on the wired controller is within the range of $\pm 10\%$ of the reading of the pressure gauge, the pressure sensor is normal. Otherwise, it is abnormal.
3. Inspection of high-pressure sensor
 - (1) Connect the pressure gauge to the gas valve and check if the gas and liquid valves are open.
 - (2) Switch the unit to the heating mode. After the system stabilizes, check the reading of the pressure gauge.
4. Check the unit's exhaust pressure via the wired controller and compare it with the reading of the pressure gauge on the gas valve. If the value shown on the wired controller is within the range of $\pm 10\%$ of the reading of the pressure gauge, the pressure sensor is normal. Otherwise, it is abnormal.

4 Replacement of Key Unit Parts

4.1 Key Parts

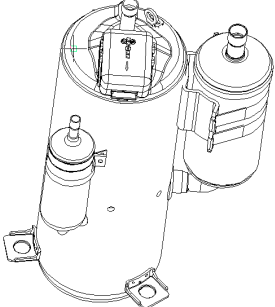
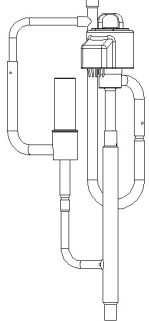
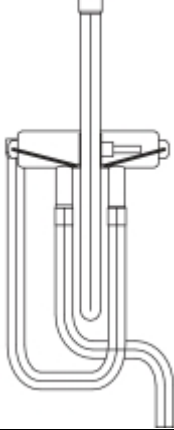
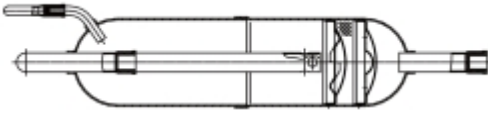
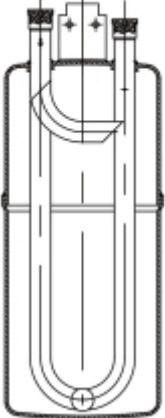

Photo	Name	Function
	<p>compressor</p>	<p>Core part of air conditioning system. It sucks low temperature and low pressure gas, compress it to high temperature and high pressure gas, and then discharge it.</p>
	<p>Electronic expansion valve</p>	<p>Throttling device. It transforms high pressure refrigerant liquid into low pressure steam.</p>
	<p>4-way valve</p>	<p>It changes the flow direction of refrigerant for switching between cooling and heating.</p>
	<p>Oil separator</p>	<p>It stays between discharge outlet of compressor and inlet of condenser. It used for separating the lubricant oil of compressor when the high temperature and high pressure refrigerant gas is discharged from the compressor.</p>
	<p>Vapour liquid separator</p>	<p>It stays between outlet of evaporator and suction outlet of compressor. It used for separating low temperature and low pressure refrigerant.</p>

Photo	Name	Function
	<p>High pressure liquid storage tank</p>	<p>It used for storing the superfluous high pressure refrigerant liquid during cooling process.</p>
	<p>Solenoid valve</p>	<p>—</p>
	<p>Cut-off valve</p>	<p>It used for connecting indoor unit and outdoor unit, and used for maintenance and installation.</p>

4.2 Removal of Key Parts

Removal operation for panel		
Remark: Before removing the panel, please make sure that the unit is disconnected with the power		
Process	Photo	Operation Instruction
1.Remove top cover		<ul style="list-style-type: none"> • Loose the screws fixing the top cover with screwdriver • Hold the top cover upwards and then put it on the floor flatly
2.Remove front side plate sub-assy		<ul style="list-style-type: none"> • Loose the screw fixing the front side plate with screwdriver • Hold the front side plate upwards and then put it on the floor flatly
3.Remove front panel and grille		<ul style="list-style-type: none"> • Loose the screws fixing the front panel and grille with screwdriver • Put the front panel and grille on the floor flatly
4.Remove left side plate and rear side plate		<ul style="list-style-type: none"> • Loose screws fixing left side plate and rear side plate with screwdriver • remove the rear side plate

Removal operation for blade		
Remark: Before removing the motor, please make sure that the unit is disconnected with the power.		
Process	Photo	Operation Instruction
1.Remove grille		<ul style="list-style-type: none"> • Loose screws fixing the panel with screwdriver • Then remove the grille
2.Remove blade		<ul style="list-style-type: none"> • Loosen nuts fixing the blade with wrench • Then remove the blade and put it on the floor flatly
3.Remove motor		<ul style="list-style-type: none"> • Loose screws fixing the motor with screwdriver • then remove the power cord of motor • Take out the damaged motor
4.Install motor		<ul style="list-style-type: none"> • Replace the motor, tighten screws with screwdriver and then connect the power cord of motor

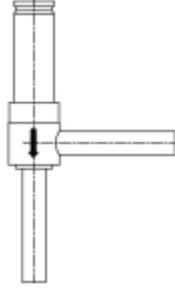
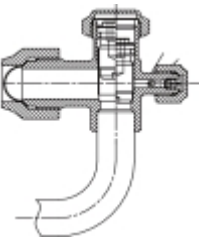
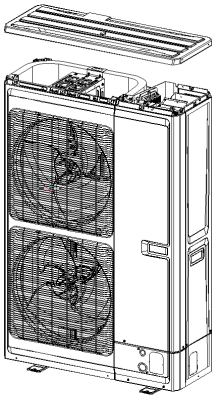
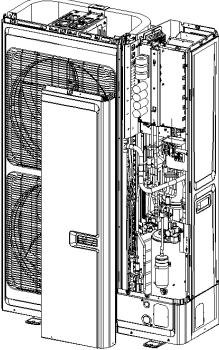
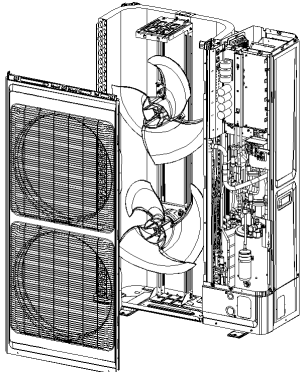
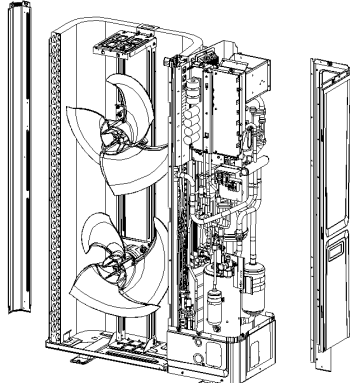
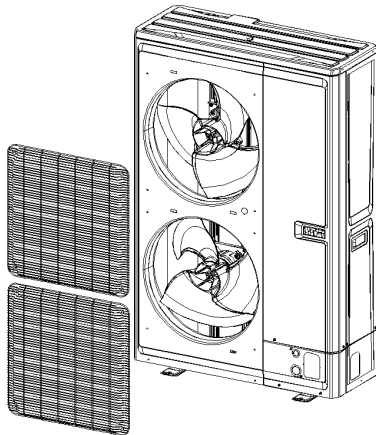
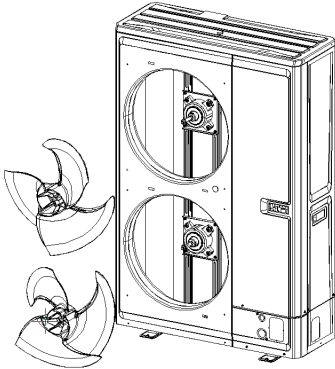
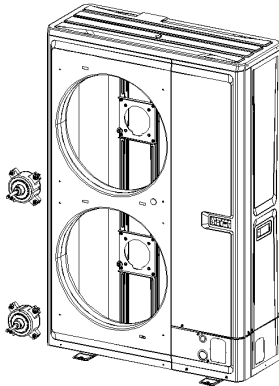
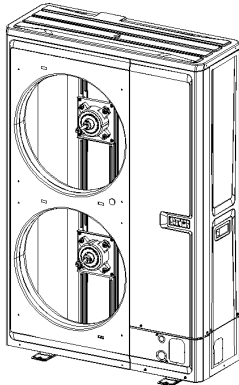
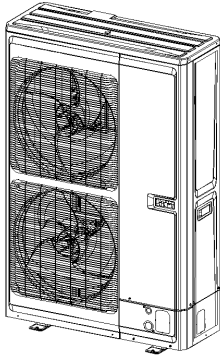
Removal operation for blade		
Remark: Before removing the motor, please make sure that the unit is disconnected with the power.		
Process	Photo	Operation Instruction
5.Assemble unit		<ul style="list-style-type: none"> • Assemble the unit in the the converse sequence

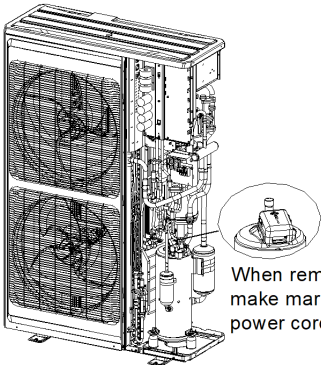
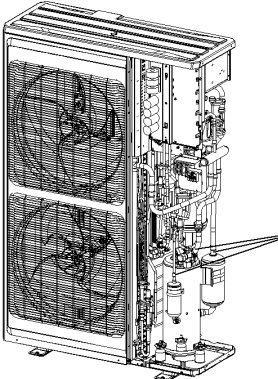
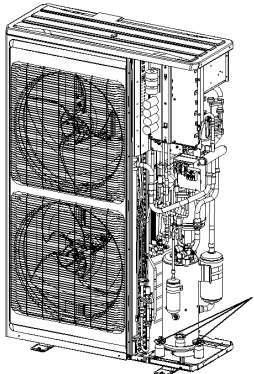
Removal operation of compressor		
Remark: Before removing the compressor, please make sure that there's no refrigerant inside the pipeline and the power is disconnected.		
Process	Photo	Operation Instruction
1.Remove wiring cover of compressor	 <p>When removing the power cord, make marks for different color power cords and corresponding</p>	<ul style="list-style-type: none"> • Loose screws fixing the compressor with screwdriver • Then pull out the power cord <p>NOTE: When removing the power cord, make marks for different color power cords and corresponding wiring terminals for wrong terminal.</p>
2.Disconnect compressor 、 vapor injection tube and connected pipeline	 <p>Weld these three points and then pull out the suction pipe、 the discharge pipe and vapor injection tube</p>	<ul style="list-style-type: none"> • Weld suction pipe、 vapor injection tube and discharge pipe of compressor • then pull out the connection pipe from the compressor <p>NOTE: During welding process, do not let the flame burn out other parts.</p>
3.Loose nuts fixing the foot of compressor	 <p>Twist off the nuts for compressor with wrench</p>	<ul style="list-style-type: none"> • Twist off the nuts for compressor with wrench

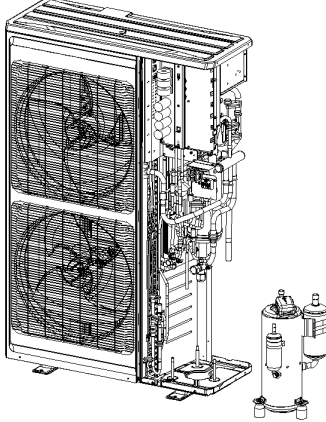
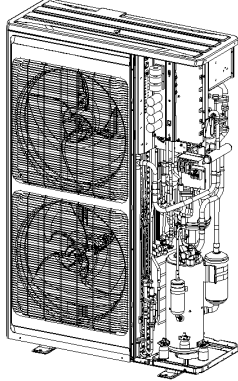
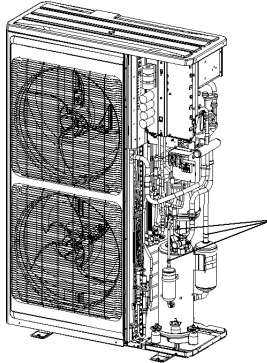
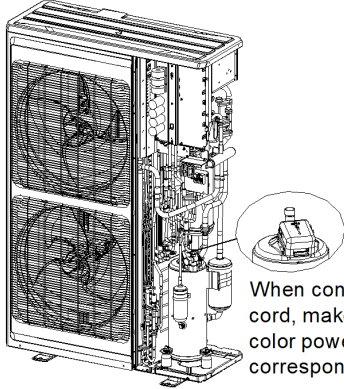
Removal operation of compressor		
Remark: Before removing the compressor, please make sure that there's no refrigerant inside the pipeline and the power is disconnected.		
Process	Photo	Operation Instruction
4.Remove the chassis from compressor		<ul style="list-style-type: none"> • Take out the compressor and replace it NOTE: When replacing the compressor, do not damage nearby pipelines and other parts
5.Fix the new compressor at the chassis		<ul style="list-style-type: none"> • After replacing the compressor, fix the nuts at the bottom of compressor
6.Connect suction pipe, vapor injection tube and discharge pipe of compressor and pipeline of system again	 <p>Connect suction pipe, vapor injection tube and discharge pipe of copressor and pipeline of system again</p>	<ul style="list-style-type: none"> • Weld the connection pipe of compressor, connect the pipeline and compressor NOTE: During welding process, do not let flame burn out other parts
7.Connect the power cord of compressor well	 <p>When connecting the power cord, make marks for different color power cords and corresponding wiring terminals</p>	<ul style="list-style-type: none"> • Loose screws fixing the power cord with screwdriver • connect the power cord well again NOTE: When connecting the power cord, make marks for different color power cords and corresponding wiring terminals

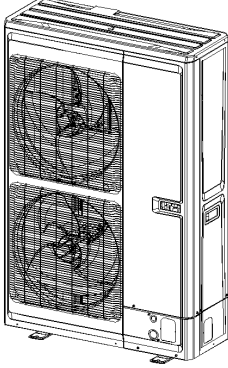
Removal operation of compressor		
Remark: Before removing the compressor, please make sure that there's no refrigerant inside the pipeline and the power is disconnected.		
Process	Photo	Operation Instruction
8. Check and open the upper cover plate		<ul style="list-style-type: none"> ● Check whether the pipeline is connected well ● Check whether all parts and connection wires are connected well ● If there's no problem after checking, install front and rear cover plates

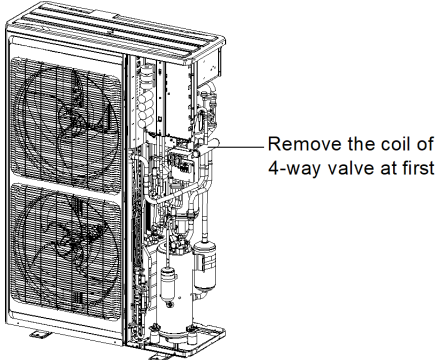
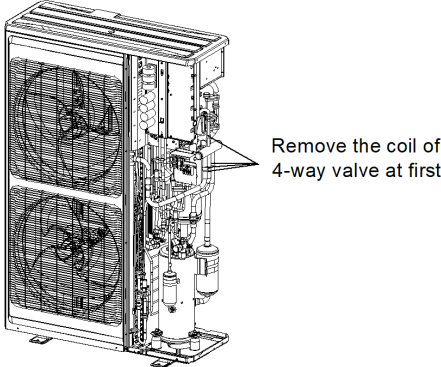
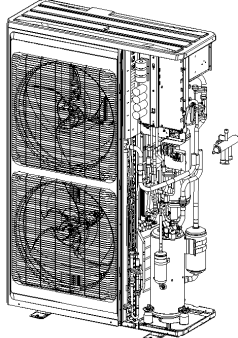
Removal operation for 4-way valve		
Remark: Before removing the 4-way valve, please make sure that there's no refrigerant inside the pipeline of system and then power is disconnected.		
Process	Photo	Operation Instruction
1. Disconnect the coil of 4-way valve from the 4-way valve		<ul style="list-style-type: none"> ● Remove the coil of 4-way valve at first
2. Disconnect the 4-way valve and connection pipeline		<ul style="list-style-type: none"> ● Weld those 4 connection spots on 4-way valve, and then pull out the connection pipe <p>NOTE: During welding process, do not let the flame burn out other parts</p>
3. Replace 4-way valve		<ul style="list-style-type: none"> ● Replace 4-way valve <p>NOTE: During welding process, do not let the flame burn out other parts</p>

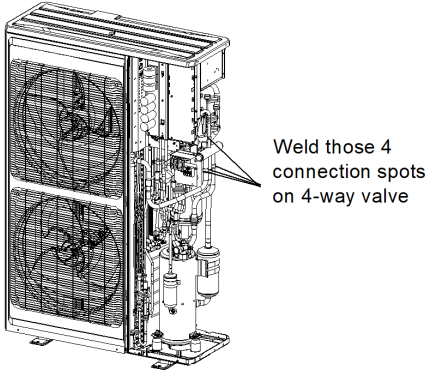
Removal operation for 4-way valve		
Remark: Before removing the 4-way valve, please make sure that there's no refrigerant inside the pipeline of system and then power is disconnected.		
Process	Photo	Operation Instruction
4. Replace 4-way valve		<ul style="list-style-type: none"> Weld the connection position between 4-way valve and pipeline <p>NOTE: During welding process, do not let flame burn out other parts</p>

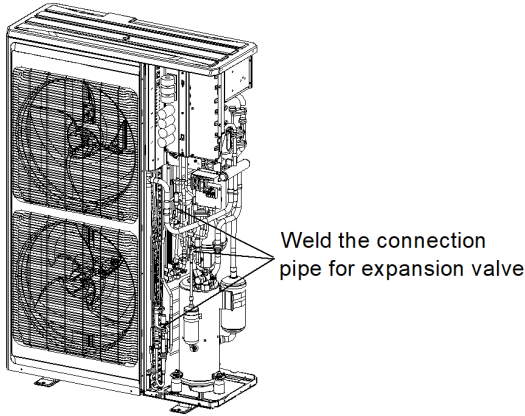
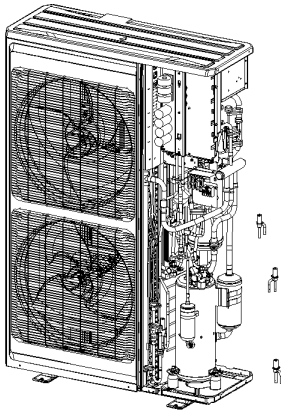
Removal operation for electronic expansion valve		
Remark: Before removing the electronic expansion valve, please make sure that there's no refrigerant in the pipeline of system and the power is disconnected		
Process	Photo	Operation Instruction
1. Disconnect the electronic expansion valve from the pipeline		<ul style="list-style-type: none"> Remove the coil of electronic expansion valve at first Weld the connection pipe for expansion valve, and then pull out the connection pipe <p>NOTE: During welding process, do not let flame burn out other parts</p>
2. Take out the electronic expansion valve and replace it		<ul style="list-style-type: none"> Take out the electronic expansion valve and replace it

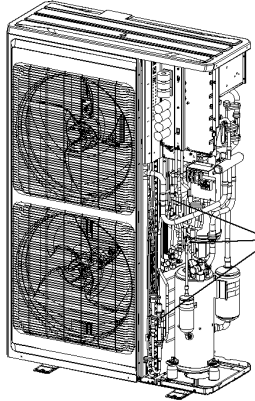
Removal operation for electronic expansion valve		
Remark: Before removing the electronic expansion valve, please make sure that there's no refrigerant in the pipeline of system and the power is disconnected		
Process	Photo	Operation Instruction
3. Replace electronic expansion valve	 <p>Weld the connection pipe for expansion valve</p>	<ul style="list-style-type: none"> • Weld the connection pipe of electronic expansion valve • Install the coil of electronic expansion valve <p>NOTE: During welding process, do not let the flame burn out other parts</p>

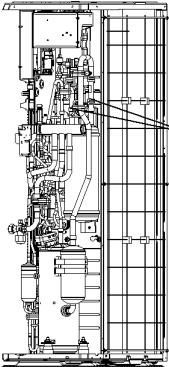
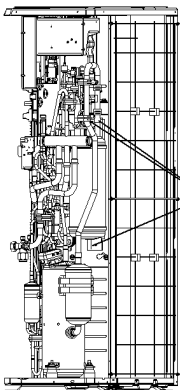
Removal operation of gas liquid separator		
Remark: Before removing the gas liquid separator, please make sure that there's no refrigerant inside the pipeline of system and disconnect the power		
Process	Photo	Operation Instruction
1. Disconnect inlet pipe and exit pipe of gas liquid separator	 <p>Weld those two connection spots on the gas liquid separator</p>	<ul style="list-style-type: none"> • Weld those two connection spots on the gas liquid separator and then pull out the connection pipe <p>NOTE: During welding process, do not let flame burn out other parts</p>
2. Replace gas liquid separator	 <p>Loose three screws</p>	<ul style="list-style-type: none"> • Loose three screws with screwdriver • Replace gas liquid separator

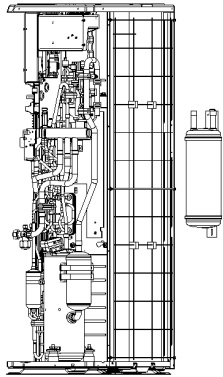
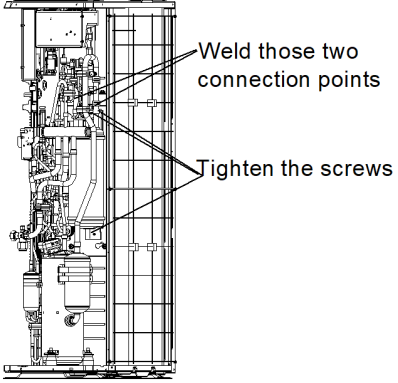
Removal operation of gas liquid separator		
Remark: Before removing the gas liquid separator, please make sure that there's no refrigerant inside the pipeline of system and disconnect the power		
Process	Photo	Operation Instruction
3. Replace gas liquid separator		<ul style="list-style-type: none"> Weld the pipe connected with gas liquid separator NOTE: During welding process, do not let flame burn out other parts
4. Replace gas liquid separator		<ul style="list-style-type: none"> Fix the screws at the base of gas liquid separator well again NOTE: During welding process, do not let flame burn out other parts

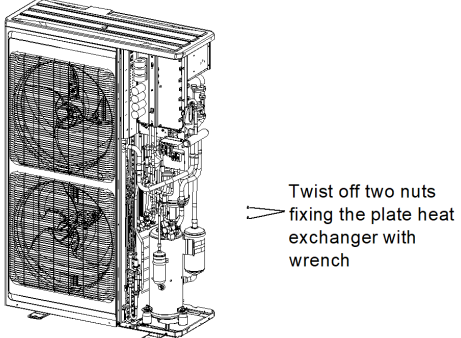
Removal operation for plate heat exchanger		
Remark: Before removing the plate heat exchanger, please make sure that there's no refrigerant inside the pipeline of system and disconnect the power		
Process	Photo	Operation Instruction
1. Twist off two nuts fixing the plate heat exchanger with wrench		<ul style="list-style-type: none"> Twist off two nuts fixing the plate heat exchanger with wrench

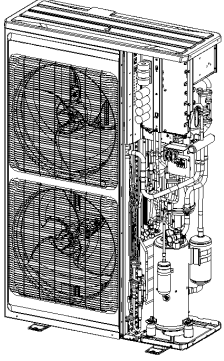
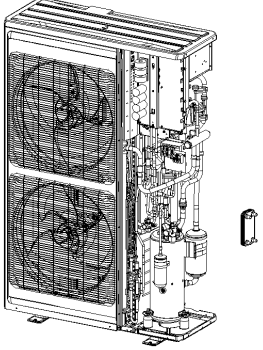
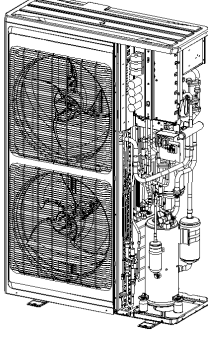
Removal operation for plate heat exchanger		
Remark: Before removing the plate heat exchanger, please make sure that there's no refrigerant inside the pipeline of system and disconnect the power		
Process	Photo	Operation Instruction
2.Disconnect inlet pipe and outlet pipe of plate heat exchanger	 <p>Weld those 4 connection spots on the plate heat exchanger</p>	<ul style="list-style-type: none"> Weld those 4 connection spots on the plate heat exchanger, and then pull out the connection pipe. <p>NOTE: During welding process, do not let flame burn out other parts</p>
3.Replace plate heat exchanger	 <p>Replace plate heat exchanger</p>	<ul style="list-style-type: none"> Replace plate heat exchanger
4..Replace plate heat exchanger	 <p>Weld the pipe connected with plate heat exchanger</p>	<ul style="list-style-type: none"> Weld the pipe connected with plate heat exchanger <p>NOTE: During welding process, do not let flame burn out other parts</p>

5 Explosive View and Parts List

GMV-V36WL/C-T(U), GMV-V48WL/C-T(U) and GMV-V60WL/C-T(U)

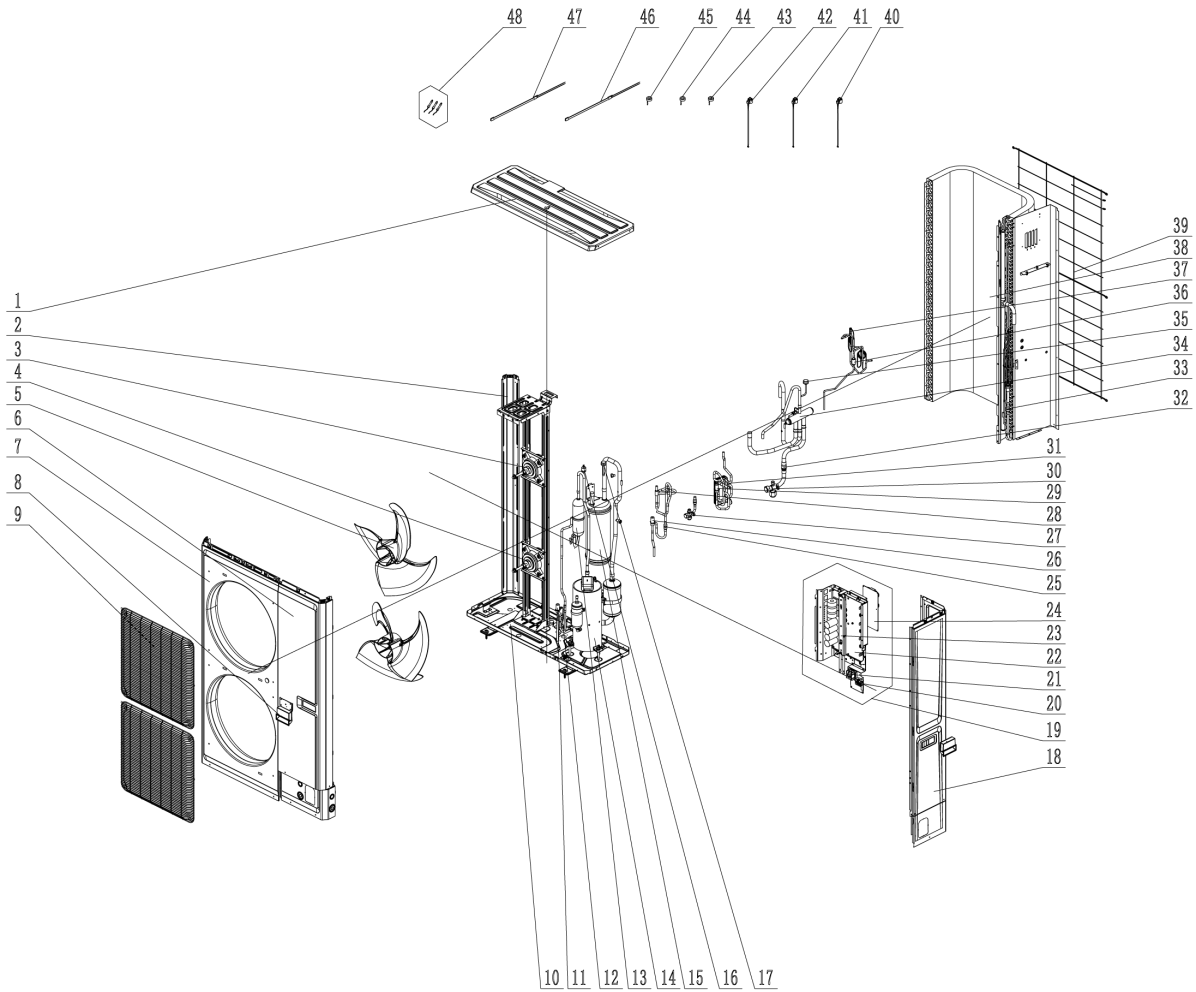

Parts list of GMV-V36WL/C-T(U), GMV-V48WL/C-T(U) and GMV-V60WL/C-T(U)

No.	Name	Material code	Qty
1	Coping	012049060098P	1
2	Left Side Plate	012055060285P	1
3	Brushless DC Motor	150104060074	1
4	Brushless DC Motor	15010406007401	1
5	Axial Flow Fan	1043410000301	2
6	Front Side Plate	012050060023P	1
7	Cabinet	012022060009P	1
8	Handle	200149060003	2
9	Front Grill	016004060002	2
10	Chassis Sub-assy	017000060951P	1
11	Electronic Expansion Valve	072009060008	1
12	Discharge Charge Valve	071015000002	1
13	Oil Separator	035028000003	1
14	Compressor and Fittings	009001060980	1
15	Gas-liquid Separator	03502706002001	1
16	Pressure Protect Switch	46020006	1

No.	Name	Material code	Qty
17	Pressure Sensor	430044060023	1
18	Connection Board	012077060725P	1
19	Electric Box Assy	100002078277	1
20	Terminal Board	42200006005403	1
21	Terminal Board	42200006001201	1
22	Main Board	300027063015	1
23	Radiator	43003406008701	1
24	Filter Board	300020060111	1
25	Strainer	035021060019	2
26	Electronic Expansion Valve	072009060041	1
27	Cut off Valve	07330000002	1
28	Electromagnetic Valve	072008060021	1
29	Electronic Expansion Valve	072009060011	1
30	Cut off Valve	07330000001	1
31	Plate-type Heat Exchanger	010007060010	1
32	Strainer	07212402	1
33	Strainer	0721212101	1
34	4-Way Valve	43000338	1
35	Pressure Sensor	430044060022	1
36	Strainer	07213046	1
37	Electromagnetic Valve	43044100144	1
38	Condenser Assy	01100206224501	1
39	Rear Grill	01574100004	1
40	Electric Expand Valve Fitting	07200206002002	1
41	Electric Expand Valve Fitting	4304413251	1
42	Electric Expand Valve Fitting	4304413261	1
43	4 Way Valve Coil	07201006000604	1
44	Magnet Coil (electromagnetic valve)	07200106001532	1
45	Magnet Coil (electromagnetic valve)	07200106001522	1
46	Electrical Heater(Compressor)	7651521216	1
47	Electrical Heater	7651000428	1
48	Sensor Sub-assy	390002060389	1

Appendixes

Appendix 1 Temperature Sensor Resistance and Temperature Relationship Table

Environmental temperature sensor 15kΩ resistance ~ voltage correspondence table (including outdoor and indoor environment temperature sensors)

Temperature (°C)	Resistance (kΩ)	Voltage (V)	Temperature (°C)	Resistance (kΩ)	Voltage (V)
-20	144	0.311	71	2.523	2.825
-19	138.1	0.323	72	2.439	2.838
-18	128.6	0.345	73	2.358	2.852
-17	121.6	0.362	74	2.28	2.865
-16	115	0.381	75	2.205	2.877
-15	108.7	0.4	76	2.133	2.889
-14	102.9	0.42	77	2.064	2.901
-13	97.4	0.44	78	1.997	2.912
-12	92.22	0.462	79	1.933	2.923
-11	87.35	0.484	80	1.871	2.934
-10	82.75	0.506	81	1.811	2.945
-9	78.43	0.53	82	1.754	2.955
-8	74.35	0.554	83	1.699	2.964
-7	70.5	0.579	84	1.645	2.974
-6	66.88	0.605	85	1.594	2.983
-5	63.46	0.631	86	1.544	2.992
-4	60.23	0.658	87	1.497	3.001
-3	57.18	0.686	88	1.451	3.009
-2	54.31	0.714	89	1.408	3.017
-1	51.59	0.743	90	1.363	3.025
0	49.02	0.773	91	1.322	3.033
1	46.8	0.801	92	1.282	3.04
2	44.31	0.835	93	1.244	3.047
3	42.14	0.866	94	1.207	3.054
4	40.09	0.899	95	1.171	3.061
5	38.15	0.931	96	1.136	3.068
6	36.32	0.965	97	1.103	3.074
7	34.58	0.998	98	1.071	3.08
8	32.94	1.033	99	1.039	3.086
9	31.38	1.067	100	1.009	3.092
10	29.9	1.102	101	0.98	3.098
11	28.51	1.138	102	0.952	3.103
12	27.18	1.174	103	0.925	3.108
13	25.92	1.21	104	0.898	3.114
14	24.73	1.246	105	0.873	3.119
15	23.6	1.282	106	0.848	3.123
16	22.53	1.319	107	0.825	3.128

Temperature (°C)	Resistance (kΩ)	Voltage (V)	Temperature (°C)	Resistance (kΩ)	Voltage (V)
17	21.51	1.356	108	0.802	3.133
18	20.54	1.393	109	0.779	3.137
19	19.63	1.429	110	0.758	3.141
20	18.75	1.467	111	0.737	3.145
21	17.93	1.503	112	0.717	3.15
22	17.14	1.54	113	0.697	3.153
23	16.39	1.577	114	0.678	3.157
24	15.68	1.613	115	0.66	3.161
25	15	1.65	116	0.642	3.165
26	14.36	1.686	117	0.625	3.168
27	13.74	1.722	118	0.608	3.171
28	13.16	1.758	119	0.592	3.175
29	12.6	1.793	120	0.577	3.178
30	12.07	1.829	121	0.561	3.181
31	11.57	1.863	122	0.547	3.184
32	11.09	1.897	123	0.532	3.187
33	10.63	1.931	124	0.519	3.19
34	10.2	1.964	125	0.505	3.192
35	9.779	1.998	126	0.492	3.195
36	9.382	2.03	127	0.48	3.198
37	9.003	2.062	128	0.467	3.2
38	8.642	2.094	129	0.456	3.203
39	5.997	2.125	130	0.444	3.205
41	7.653	2.185	131	0.433	3.207
42	7.352	2.215	132	0.422	3.21
43	7.065	2.243	133	0.412	3.212
44	6.791	2.272	134	0.401	3.214
45	6.529	2.299	135	0.391	3.216
46	6.278	2.326	136	0.382	3.218
47	6.038	2.353	137	0.372	3.22
48	5.809	2.379	138	0.363	3.222
49	5.589	2.404	139	0.355	3.224
50	5.379	2.429	140	0.346	3.226
51	5.179	2.453	141	0.338	3.227
52	4.986	2.477	142	0.33	3.229
53	4.802	2.5	143	0.322	3.231
54	4.625	2.522	144	0.314	3.232
55	4.456	2.544	145	0.307	3.234
56	4.294	2.566	146	0.299	3.235
57	4.139	2.586	147	0.292	3.237
58	3.99	2.607	148	0.286	3.238
59	3.848	2.626	149	0.279	3.24
60	3.711	2.646	150	0.273	3.241
61	3.579	2.664	151	0.266	3.242
62	3.454	2.682	152	0.261	3.244

Temperature (°C)	Resistance (kΩ)	Voltage (V)	Temperature (°C)	Resistance (kΩ)	Voltage (V)
63	3.333	2.7	153	0.254	3.245
64	3.217	2.717	154	0.248	3.246
65	3.105	2.734	155	0.243	3.247
66	2.998	2.75	156	0.237	3.249
67	2.898	2.766	157	0.232	3.25
68	2.797	2.781	158	0.227	3.251
69	2.702	2.796	159	0.222	3.252
70	2.611	2.811	160	0.217	3.253

Pipeline temperature sensor 20kΩ resistance ~ voltage correspondence table (including defrosting temperature sensor, subcooler temperature sensor, gas-liquid separator temperature sensor, IDU inlet and outlet tube temperature sensor)

Temperature (°C)	Resistance (kΩ)	Voltage (V)	Temperature (°C)	Resistance (kΩ)	Voltage (V)
-30	361.8	0.173	66	3.998	2.75
-29	339.8	0.183	67	3.861	2.766
-28	319.2	0.195	68	3.729	2.781
-27	300	0.206	69	3.603	2.796
-26	282.2	0.218	70	3.481	2.811
-25	265.5	0.231	71	3.364	2.825
-24	249.9	0.245	72	3.252	2.838
-23	235.3	0.259	73	3.144	2.852
-22	221.6	0.273	74	3.04	2.865
-21	208.9	0.288	75	2.94	2.877
-20	196.9	0.304	76	2.844	2.889
-19	181.4	0.328	77	2.752	2.901
-18	171.4	0.345	78	2.663	2.912
-17	162.1	0.362	79	2.577	2.923
-16	153.3	0.381	80	2.495	2.934
-15	145	0.4	81	2.415	2.944
-14	137.2	0.42	82	2.339	2.954
-13	129.9	0.44	83	2.265	2.964
-12	123	0.462	84	2.194	2.974
-11	116.5	0.484	85	2.125	2.983
-10	110.3	0.507	86	2.059	2.992
-9	104.6	0.53	87	1.996	3.001
-8	99.13	0.554	88	1.934	3.009
-7	94	0.579	89	1.875	3.017
-6	89.17	0.605	90	1.818	3.025
-5	84.61	0.631	91	1.763	3.033
-4	80.31	0.658	92	1.71	3.04
-3	76.24	0.686	93	1.658	3.047
-2	72.41	0.714	94	1.609	3.054
-1	68.79	0.743	95	1.561	3.061
0	65.37	0.773	96	1.515	3.068

Temperature (°C)	Resistance (kΩ)	Voltage (V)	Temperature (°C)	Resistance (kΩ)	Voltage (V)
1	62.13	0.804	97	1.47	3.074
2	59.08	0.835	98	1.427	3.08
3	56.19	0.866	99	1.386	3.086
4	53.46	0.898	100	1.346	3.092
5	50.87	0.931	101	1.307	3.098
6	48.42	0.965	102	1.269	3.103
7	46.11	0.998	103	1.233	3.108
8	43.92	1.033	104	1.198	3.114
9	41.84	1.067	105	1.164	3.119
10	39.87	1.102	106	1.131	3.123
11	38.01	1.138	107	1.099	3.128
12	36.24	1.174	108	1.069	3.133
13	34.57	1.209	109	1.039	3.137
14	32.98	1.246	110	1.01	3.141
15	31.47	1.282	111	0.9825	3.145
16	30.04	1.319	112	0.9556	3.15
17	28.68	1.356	113	0.9295	3.153
18	27.39	1.393	114	0.9043	3.157
19	26.17	1.429	115	0.8799	3.161
20	25.01	1.466	116	0.8562	3.165
21	23.9	1.503	117	0.8333	3.168
22	22.85	1.54	118	0.8111	3.171
23	21.85	1.577	119	0.7895	3.175
24	20.9	1.614	120	0.7687	3.178
25	20	1.65	121	0.7485	3.181
26	19.14	1.686	122	0.7289	3.184
27	18.32	1.722	123	0.7099	3.187
28	17.55	1.758	124	0.6915	3.19
29	16.8	1.793	125	0.6736	3.192
30	16.1	1.828	126	0.6563	3.195
31	15.43	1.863	127	0.6395	3.198
32	14.79	1.897	128	0.6232	3.2
33	14.18	1.931	129	0.6074	3.203
34	13.59	1.965	130	0.5921	3.205
35	13.04	1.998	131	0.5772	3.207
36	12.51	2.03	132	0.5627	3.21
37	12	2.063	133	0.5487	3.212
38	11.52	2.094	134	0.5351	3.214
39	11.06	2.125	135	0.5219	3.216
40	10.62	2.155	136	0.509	3.218
41	10.2	2.185	137	0.4966	3.22
42	9.803	2.215	138	0.4845	3.222
43	9.42	2.243	139	0.4727	3.224
44	9.054	2.272	140	0.4613	3.226
45	8.705	2.299	141	0.4502	3.227

Temperature (°C)	Resistance (kΩ)	Voltage (V)	Temperature (°C)	Resistance (kΩ)	Voltage (V)
46	8.37	2.326	142	0.4394	3.229
47	8.051	2.353	143	0.4289	3.231
48	7.745	2.379	144	0.4187	3.232
49	7.453	2.404	145	0.4088	3.234
50	7.173	2.429	146	0.3992	3.235
51	6.905	2.453	147	0.3899	3.237
52	6.648	2.477	148	0.3808	3.238
53	6.403	2.5	149	0.3719	3.24
54	6.167	2.522	150	0.3633	3.241
55	5.942	2.544	151	0.3549	3.242
56	5.726	2.565	152	0.3468	3.244
57	5.519	2.586	153	0.3389	3.245
58	5.32	2.607	154	0.3312	3.246
59	5.13	2.626	155	0.3237	3.247
60	4.948	2.646	156	0.3164	3.249
61	4.773	2.664	157	0.3093	3.25
62	4.605	2.682	158	0.3024	3.251
63	4.443	2.7	159	0.2956	3.252
64	4.289	2.717	160	0.2891	3.253
65	4.14	2.734	—	—	—

Exhaust temperature sensor 50kΩ resistance ~ voltage correspondence table (including compressor top shell temperature sensor and air exhaust pipe temperature sensor)

Temperature (°C)	Resistance (kΩ)	Voltage (V)	Temperature (°C)	Resistance (kΩ)	Voltage (V)
-30	911.56	0.036	61	11.736	1.518
-29	853.66	0.038	62	11.322	1.548
-28	799.98	0.041	63	10.925	1.577
-27	750.18	0.043	64	10.544	1.606
-26	703.92	0.046	65	10.178	1.635
-25	660.93	0.049	66	9.8269	1.664
-24	620.94	0.052	67	9.4896	1.693
-23	583.72	0.056	68	9.1655	1.722
-22	549.04	0.059	69	8.9542	1.741
-21	516.71	0.063	70	8.5551	1.778
-20	486.55	0.066	71	5.9676	1.806
-19	458.4	0.07	72	7.9913	1.834
-18	432.1	0.075	73	7.7257	1.862
-17	407.51	0.079	74	7.4702	1.889
-16	384.51	0.084	75	7.2245	1.916
-15	362.99	0.088	76	6.9882	1.943
-14	342.83	0.094	77	6.7608	1.969
-13	323.94	0.099	78	6.542	1.995
-12	306.23	0.104	79	6.3315	2.021
-11	289.61	0.11	80	6.1288	2.046

Temperature (°C)	Resistance (kΩ)	Voltage (V)	Temperature (°C)	Resistance (kΩ)	Voltage (V)
-10	274.02	0.116	81	5.9336	2.071
-9	259.37	0.123	82	5.7457	2.096
-8	245.61	0.129	83	5.5647	2.12
-7	232.67	0.136	84	5.3903	2.144
-6	220.5	0.143	85	5.2223	2.168
-5	209.05	0.151	86	5.0605	2.191
-4	195.97	0.158	87	4.9044	2.214
-3	188.12	0.167	88	4.7541	2.237
-2	178.65	0.175	89	4.6091	2.259
-1	169.68	0.184	90	4.4693	2.281
0	161.02	0.193	91	4.3345	2.302
1	153	0.202	92	4.2044	2.323
2	145.42	0.212	93	4.0789	2.344
3	135.96	0.223	94	3.9579	2.364
4	131.5	0.233	95	3.841	2.384
5	126.17	0.242	96	3.7283	2.404
6	119.08	0.256	97	3.6194	2.423
7	113.37	0.267	98	3.5143	2.442
8	107.96	0.28	99	3.4128	2.46
9	102.85	0.292	100	3.3147	2.478
10	98.006	0.306	101	3.22	2.496
11	93.42	0.319	102	3.1285	2.514
12	89.075	0.333	103	3.0401	2.531
13	84.956	0.348	104	2.9547	2.547
14	81.052	0.362	105	2.8721	2.564
15	77.349	0.378	106	2.7922	2.58
16	73.896	0.393	107	2.715	2.595
17	70.503	0.41	108	2.6404	2.611
18	67.338	0.427	109	2.5682	2.626
19	64.333	0.444	110	2.4983	2.64
20	61.478	0.462	111	2.4308	2.655
21	58.766	0.48	112	2.3654	2.669
22	56.189	0.499	113	2.3021	2.682
23	53.738	0.518	114	2.2409	2.696
24	51.408	0.537	115	2.1816	2.709
25	49.191	0.558	116	2.1242	2.722
26	47.082	0.578	117	2.0686	2.734
27	45.074	0.599	118	2.0148	2.747
28	43.163	0.621	119	1.9626	2.759
29	41.313	0.643	120	1.9123	2.77
30	39.61	0.665	121	1.8652	2.781
31	37.958	0.688	122	1.8158	2.793
32	36.384	0.711	123	1.7698	2.804
33	34.883	0.735	124	1.7253	2.814
34	33.453	0.759	125	1.6821	2.825

Temperature (°C)	Resistance (kΩ)	Voltage (V)	Temperature (°C)	Resistance (kΩ)	Voltage (V)
35	32.088	0.784	126	1.6402	2.835
36	30.787	0.809	127	1.5996	2.845
37	29.544	0.835	128	1.5602	2.855
38	28.359	0.86	129	1.522	2.864
39	27.227	0.886	130	1.485	2.873
40	26.147	0.913	131	1.449	2.882
41	25.114	0.94	132	1.4141	2.891
42	24.128	0.967	133	1.3803	2.9
43	23.186	0.994	134	1.3474	2.908
44	22.286	1.022	135	1.3155	2.916
45	21.425	1.05	136	1.2846	2.924
46	20.601	1.078	137	1.2545	2.932
47	19.814	1.107	138	1.2233	2.94
48	19.061	1.136	139	1.1969	2.947
49	18.34	1.164	140	1.1694	2.955
50	17.651	1.193	141	1.1476	2.96
51	16.99	1.223	142	1.1166	2.969
52	16.358	1.252	143	1.0913	2.975
53	15.753	1.281	144	1.0667	2.982
54	15.173	1.311	145	1.0429	2.988
55	14.618	1.34	146	1.0197	2.995
56	14.085	1.37	147	0.9971	3.001
57	13.575	1.4	148	0.9752	3.007
58	13.086	1.429	149	0.9538	3.013
59	12.617	1.459	150	0.9331	3.018
60	12.368	1.475	—	—	—

Appendix 2 Refrigerant Temperature and Pressure Table

Refrigerant: R410A

Temperature (°C)	Corresponding saturation pressure (BAR)	Temperature (°C)	Corresponding saturation pressure (BAR)	Temperature (°C)	Corresponding saturation pressure (BAR)
-43	1.54	-9	5.96	25	16.4
-42	1.61	-8	6.16	26	16.9
-41	1.68	-7	6.37	27	17.3
-40	1.76	-6	6.58	28	17.8
-39	1.84	-5	6.80	29	18.5
-38	1.93	-4	7.03	30	18.7
-37	2.02	-3	7.26	31	19.2
-36	2.11	-2	7.50	32	19.7
-35	2.24	-1	7.74	33	20.2
-34	2.33	0	7.99	34	20.7
-33	2.43	1	8.24	35	21.2
-32	2.53	2	8.50	36	21.7
-31	2.64	3	8.77	37	22.3
-30	2.75	4	9.04	38	22.8
-29	2.86	5	9.32	39	23.4
-28	2.98	6	9.61	40	24.0
-27	3.10	7	9.90	41	24.6
-26	3.22	8	10.2	42	25.2
-25	3.35	9	10.5	43	25.8
-24	3.48	10	10.8	44	26.4
-23	3.61	11	11.1	45	27.0
-22	3.75	12	11.5	46	27.7
-21	3.89	13	11.8	47	28.3
-20	4.04	14	12.1	48	29.0
-19	4.19	15	12.5	49	29.6
-18	4.35	16	12.8	50	30.3
-17	4.51	17	13.2	52	31.7
-16	4.67	18	13.6	54	33.2
-15	4.84	19	14.0	56	34.7
-14	5.02	20	14.4	58	36.3
-13	5.19	21	14.7	60	37.9
-12	5.38	22	15.2	62	40.17
-11	5.57	23	15.6	65	42.78
-10	5.76	24	16.0	67	44.57

Appendix 3 Pressure Sensor Voltage and Pressure Table

High-pressure sensor features (R410A)

Temperature (°C)	Absolute pressure (kPA)	Voltage (V)	Temperature (°C)	Absolute pressure (kPA)	Voltage (V)
-40	176	0.102	16	1300	1.3
-39	184	0.111	17	1337	1.34
-38	193	0.12	18	1375	1.38
-37	202	0.13	19	1413	1.421
-36	211	0.139	20	1453	1.463
-35	220	0.149	21	1493	1.506
-34	230	0.16	22	1535	1.551
-33	240	0.17	23	1577	1.596
-32	250	0.181	24	1620	1.641
-31	261	0.193	25	1664	1.688
-30	273	0.206	26	1708	1.735
-29	283	0.216	27	1754	1.784
-28	295	0.229	28	1801	1.834
-27	307	0.242	29	1848	1.884
-26	319	0.255	30	1897	1.937
-25	332	0.268	31	1946	1.989
-24	345	0.282	32	1996	2.042
-23	359	0.297	33	2048	2.098
-22	373	0.312	34	2100	2.153
-21	388	0.328	35	2153	2.21
-20	403	0.344	36	2208	2.268
-19	418	0.36	37	2263	2.327
-18	434	0.377	38	2320	2.388
-17	450	0.394	39	2377	2.448
-16	467	0.412	40	2436	2.511
-15	484	0.43	41	2495	2.574
-14	502	0.45	42	2556	2.639
-13	520	0.469	43	2618	2.705
-12	538	0.488	44	2681	2.772
-11	558	0.509	45	2745	2.841
-10	577	0.53	46	2810	2.91
-9	597	0.551	47	2876	2.98
-8	618	0.573	48	2944	3.053
-7	639	0.596	49	3013	3.126
-6	661	0.619	50	3083	3.201
-5	684	0.644	51	3154	3.277
-4	707	0.668	52	3226	3.353
-3	730	0.693	53	3300	3.432
-2	754	0.718	54	3374	3.511

Temperature (°C)	Absolute pressure (kPA)	Voltage (V)	Temperature (°C)	Absolute pressure (kPA)	Voltage (V)
-1	779	0.745	55	3450	3.592
0	804	0.772	56	3528	3.675
1	830	0.799	57	3606	3.759
2	857	0.828	58	3686	3.844
3	884	0.857	59	3767	3.93
4	912	0.887	60	3849	4.018
5	940	0.917	61	3932	4.106
6	969	0.947	62	4017	4.197
7	999	0.979	63	4103	4.288
8	1030	1.012	64	4190	4.381
9	1061	1.046	65	4278	4.475
10	1093	1.08	66	4367	4.57
11	1125	1.114	67	4457	4.666
12	1159	1.15	68	4548	4.763
13	1193	1.186	69	4639	4.86
14	1228	1.224	70	4731	4.958
15	1263	1.261	71	4893	5.13

Low-pressure sensor features (R410A)

Temperature (°C)	Absolute pressure (kPA)	Voltage (V)	Temperature (°C)	Absolute pressure (kPA)	Voltage (V)
-70	36	0.369	-14	502	1.301
-69	38	0.373	-13	520	1.337
-68	40	0.377	-12	538	1.373
-67	43	0.383	-11	558	1.413
-66	46	0.389	-10	577	1.451
-65	48	0.393	-9	597	1.491
-64	51	0.399	-8	618	1.533
-63	54	0.405	-7	639	1.575
-62	57	0.411	-6	661	1.619
-61	61	0.419	-5	684	1.665
-60	64	0.425	-4	707	1.711
-59	68	0.433	-3	730	1.757
-58	72	0.441	-2	754	1.805
-57	76	0.449	-1	799	1.895
-56	80	0.457	0	804	1.905
-55	84	0.465	1	830	1.957
-54	89	0.475	2	857	2.011
-53	94	0.485	3	884	2.065
-52	99	0.495	4	912	2.121
-51	104	0.505	5	940	2.177
-50	109	0.515	6	969	2.235
-49	115	0.527	7	999	2.295
-48	121	0.539	8	1030	2.357
-47	127	0.551	9	1061	2.419
-46	133	0.563	10	1096	2.489

Temperature (°C)	Absolute pressure (kPA)	Voltage (V)	Temperature (°C)	Absolute pressure (kPA)	Voltage (V)
-45	140	0.577	11	1125	2.547
-44	146	0.589	12	1159	2.615
-43	154	0.605	13	1193	2.683
-42	161	0.619	14	1228	2.753
-41	168	0.633	15	1263	2.823
-40	176	0.649	16	1300	2.897
-39	184	0.665	17	1337	2.971
-38	193	0.683	18	1375	3.047
-37	202	0.701	19	1413	3.123
-36	211	0.719	20	1453	3.203
-35	220	0.737	21	1493	3.283
-34	230	0.757	22	1535	3.367
-33	240	0.777	23	1577	3.451
-32	250	0.797	24	1620	3.537
-31	261	0.819	25	1664	3.625
-30	272	0.841	26	1708	3.713
-29	283	0.863	27	1754	3.805
-28	295	0.887	28	1801	3.899
-27	307	0.911	29	1848	3.993
-26	319	0.935	30	1897	4.091
-25	332	0.961	31	1946	4.189
-24	345	0.987	32	1996	4.289
-23	359	1.015	33	2048	4.393
-22	373	1.043	34	2100	4.497
-21	388	1.073	35	2153	4.603
-20	403	1.103	36	2208	4.713
-19	418	1.133	37	2263	4.823
-18	434	1.165	38	2320	4.937
-17	450	1.197	39	2377	5.051
-16	467	1.231	40	2439	5.175
-15	484	1.265	—	—	—

Appendix 4 Electric Specifications

⚠ WARNING

- (1) All electrical installation must be performed by qualified technicians in accordance with local laws, regulations and this user manual.
- (2) Use air conditioner specialized power supply and make sure that it is consistent with system's rated voltage.
- (3) Do not pull the power cord with force.
- (4) Caliber of the power cord must be large enough. A damaged power cord or connection wire must be replaced by specialized electrical cords.
- (5) Connect the unit to specialized grounding device and make sure it is securely grounded. It's a must to install air switch and current circuit breaker that can cut off the power of the entire system. The air switch should include magnetic trip function and thermal trip function so that system can be protected from short circuit and overload.
- (6) Air conditioner belongs to class I electrical appliance, so it must be securely grounded.
- (7) The yellow-green wire inside the unit is a ground wire. Do not cut it off or secure it with tapping screws, otherwise it will lead to electric shock.
- (8) Power supply must include secure grounding terminal. Do not connect the ground wire to the following: ①Water pipe; ②Gas pipe; ③Drain pipe; ④Other places that are deemed as not secure by professional technicians.
- (9) Be sure the power supply has been cut off and the capacitor on the main board has been discharged prior to electric wiring and service.
- (10) Do not change any part; and do not shield, shortcut or remove any part.

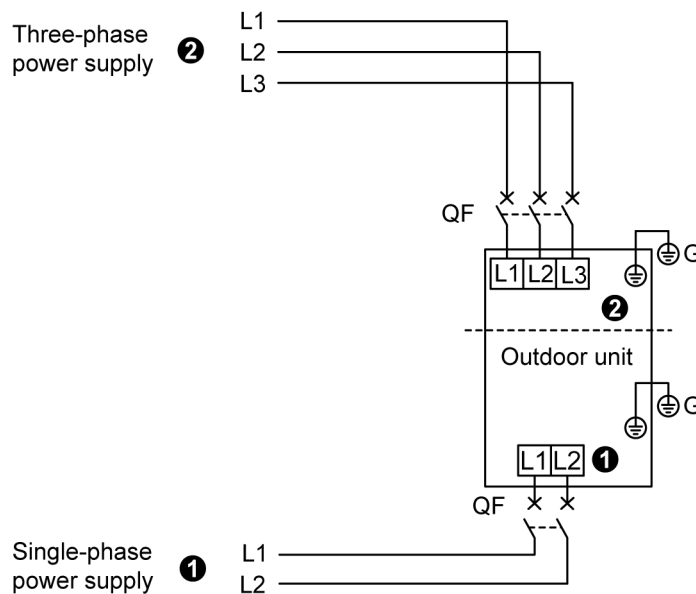

NOTE: For single-phase units, connect wires according to drawing ①; for three-phase units, connect wires according to drawing ②.

NOTE: Connect the power cord to the corresponding terminal and grounding screws. Please refer to the circuit diagram for wiring.

⚠ WARNING

- (1) Before starting work, check that power is not being supplied to the indoor unit and outdoor unit.
- (2) Wrong wire connection may burn the electrical components.
- (3) Connect the connection cords firmly to the terminal block. Imperfect installation may cause a fire.
- (4) Always connect the ground wire.

Electrical Parameters:

Model	Power Supply	Fuse Capacity (A)	Maximum Over-Current Protection (A)	Minimum Circuit Ampacity (A)
GMV-V36WL/C-T(U)	208/230V-1Ph-60Hz	35	35	33.8
GMV-V48WL/C-T(U)	208/230V-1Ph-60Hz	40	40	38.8
GMV-V60WL/C-T(U)	208/230V-1Ph-60Hz	40	40	38.8

Engineering Wiring of Power Supply and Communication Cable:

- (1) Please refer to the following part for wiring. Connect the power cord and communication cord to the corresponding wiring board and grounding screws according to the circuit diagram.
- (2) The wiring shall not touch the pipeline, edge and device.
- (3) For the wiring of power and communication cord, the picture is for reference only. If there're discrepancies between it and the structure in the picture, the actual unit shall prevail.
- (4) Wiring is subject to the self-equipped diagram of the unit used at present.

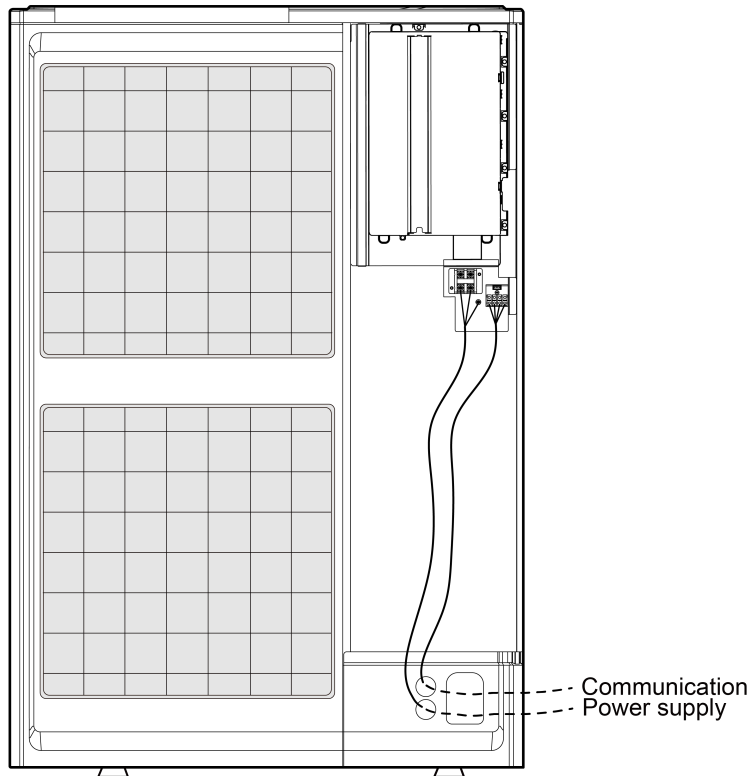

Appendix 5 Circuit Diagram

GMV-V36WL/C-T(U), GMV-V48/C-T(U), GMV-V60WL/C-T(U)

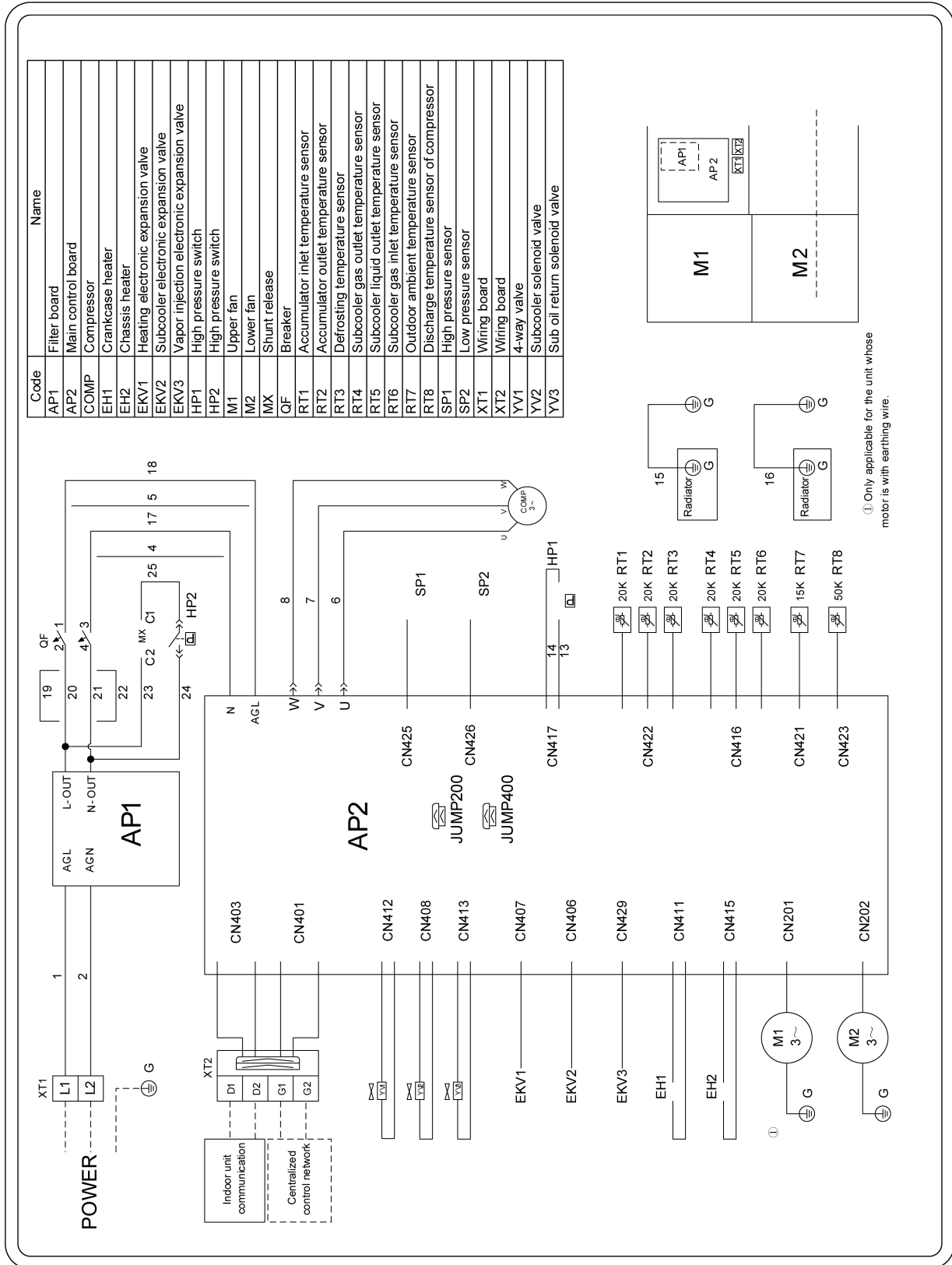

Note: Refer to the mark on the unit for the actual circuit diagram.

Appendix 6 Schematic Diagram

The working principle of Ultra Heat GMV6 Mini is as follows: when the indoor unit is running in the cooling mode, the outdoor unit starts the outdoor module according to the running load demand of the indoor unit. The outdoor heat exchanger is used as the condenser of the system, and the heat exchangers of indoor units are connected in parallel as the evaporator of system. It realizes the adjustment of the air temperature and humidity for indoor space through the return air circulation of the indoor unit; when the indoor unit is in the heating mode, all the four-way valves of the outdoor unit are switched to the energizing state, the outdoor heat exchanger is used as the evaporator of the system and the heat exchanger of indoor unit is used as the condenser of the system. The air temperature and humidity in the indoor space is realized by the return air circulation of the indoor unit.

Working principle diagrams:

System principle diagram of GMV-V36WL/C-T(U)、GMV-V48/C-T(U)、GMV-V60WL/C-T(U)

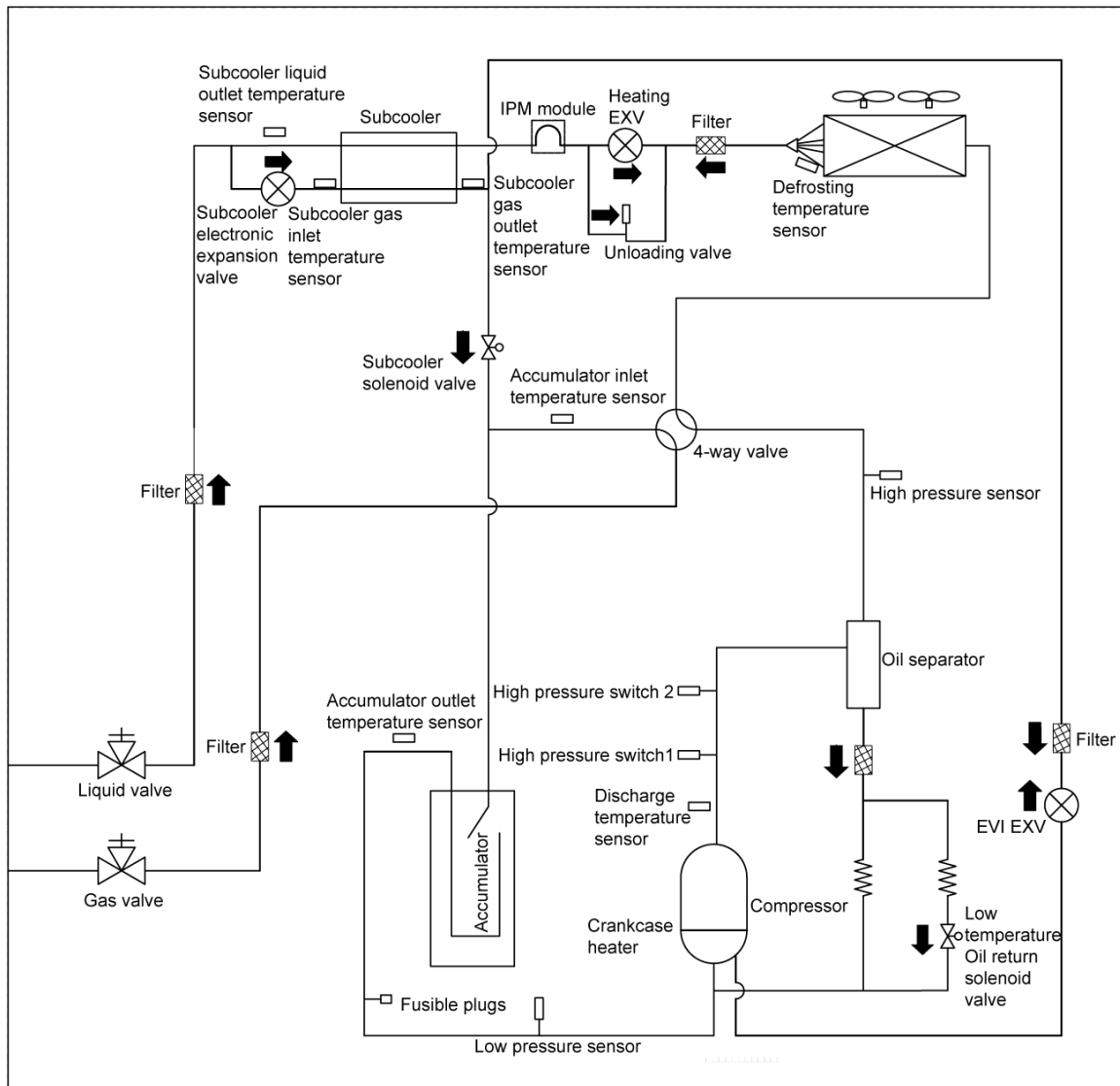

The arrows in the illustration indicate the mounting direction of the components.

Appendix 7 Names and Functions of Components

No.	Name	Main Functions
1	Compressor	The compressor changes its speed according to the actual system need for capacity adjustment.
2	Crankcase heater	In the standby state, the oil temperature of the compressor is guaranteed to prevent backflow.
3	Discharge temperature sensor of the inverter compressor	The exhaust temperature of the compressor is detected to achieve the purpose of controlling and protecting the compressor.
4	High pressure switch	When the exhaust pressure of the compressor exceeds the action value of the high-pressure switch, the feedback signal immediately stops the operation of the whole unit to achieve the purpose of protecting the compressor.
5	Oil separator	It separates the system's gas and oil to ensure the reliability of the compressor.
6	Enthalpy-adding electronic expansion valve	It is used to control the EVI capacity of the compressor.
7	High pressure sensor	It detects real-time high voltage values of the system, protects the compressor and realizes other control purposes.
8	4-way valve	It is used for cooling and heating switching of the IDU.
9	Heat exchanger	It is used for outdoor heat exchange.
10	Fan	It improves the heat exchange efficiency.
11	Defrosting temperature sensor	It is used to detect defrosting.
12	Heating electronic expansion valve	It adjusts the refrigerant in heating mode
13	Electronic expansion valve of the sub-cooler	It is used to control the liquid pipe refrigerant subcooling degree during the cooling operation of the system and reduce the loss of the pipeline capacity.
14	Sub-cooler	It is used to control the liquid pipe subcooling degree.
15	Liquid outlet temperature sensor of the sub-cooler	It is used to detect the liquid pipe temperature.
16	Inlet temperature sensor of the gas-liquid separator	It is used to check the inlet temperature of the gas-liquid separator to prevent liquid refrigerant from entering the system.
17	Gas inlet temperature sensor of the sub-cooler	It is used to detect the gas pipe temperature.
18	Low pressure sensor	It is used to detect the low pressure of the system and prevent the operation pressure from being too low.
19	Gas-liquid separator	It separates the gas and liquid and prevents liquid refrigerant from entering the compressor.
20	Outlet temperature sensor of the gas-liquid separator	It is used to detect the internal state of the gas-liquid separator and further control the suction state of the compressor.
21	Liquid valve	It is closed after the unit is delivered from the factory.
22	Gas valve	It is closed after the unit is delivered from the factory.
23	Unloading valve	It prevents a dead zone in the pipeline, which may cause over high pressure.
24	Low-temperature oil-return solenoid valve	It is used to control the connection of the compressor return oil pipeline.



GREE ELECTRIC APPLIANCES, INC. OF ZHUHAI 519070

Add: West Jinji Rd, Qianshan Zhuhai, Guangdong, China

Tel: (+86-756)8522218

Fax: (+86-756)8669426

E-mail: global@cn.gree.com www.gree.com

JF00305377