



Utral Heat Condensing Unit

Outdoor Model: KU60UXO



Indoor Model: KU60UXI



Model	Indoor Unit		KU60UXI
	Outdoor Unit		KU60UXO
Capacity	Cooling Capacity	Btu/h	53000
	Heating Capacity	Btu/h	54000
Power Input	Cooling	kW	4.53
	Heating	kW	4.65
SEER 2/ HSPF2	—		18.50~19.00/ 10.00~10.50
Indoor Unit			KU60UXI
Fan	Drive	—	Direct
	Motor Output	kW	0.75×1
	Air Flow	m ³ /h (CFM)	2550 (1500)
	Rated Ext. Static Pressure	Pa (InWg)	125 (0.50)
	Ext. Static Pressure Range	Pa (InWg)	0~250 (0-1.0)
Sound Pressure Level(H/M/L)	dB(A)		53
Air Filter	—		Metal
Drain Piping	mm (inch)		Φ25.4×1.2 (Φ1×0.05)
Outline Dimensions (W×D×H)	mm (inch)		630×540×1320 (24-13/16×21-1/4×51.968)
Net Weight	kg (lb)		90.5 (199.5)
Outdoor Unit			KU60UXO
Power Supply	—		208/230V-1Ph-60Hz
Heat Exchange	—		Inner Groove Copper Tube-Aluminum Fin
Compressor	Type	—	Inverter Rotary
Refrigerant	Control	—	Electronic Expansion Valve
	Charge	kg (oz)	4.6 (162.3)
Outline Dimensions (W×H×D)	mm (inch)		900×340×1260 (35-7/16×13-3/8×49-5/8)
Net Weight	kg (lb)		109.5 (241.4)
Piping Connections	Liquid	Inch	3/8"
	Gas	Inch	3/4"
	Max. Length	m (ft)	30 (98.4)
	Max. Height	m (ft)	15 (49.2)



Job Name:

Schedule Reference:

Date:

Specification are subject to change without notice.



Outline and Physical Dimensions of KU60UXO.

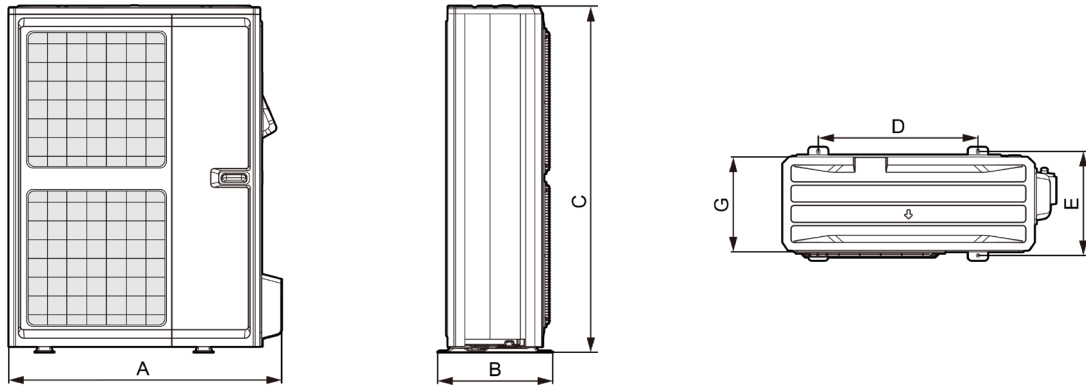

Unit: inch(mm)

Model \ Item	A	B	C	D	E	F
KU60UXO	35-7/16 (900)	16-1/4 (412)	49-5/8 (1260)	22-7/16 (570)	14-7/8 (378)	13-3/8 (340)

Outline and Physical Dimensions of KU60UXI.

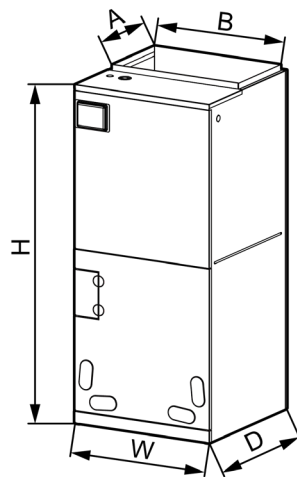

Unit: inch(mm)

Model	Dimension				
	W	D	H	A	B
KU60UXI	24-13/16 (630)	21-1/4 (540)	52 (1320)	11-5/8 (295)	20 (508)



GREE ELECTRIC APPLIANCES, INC. OF ZHUHAI

Add: Room 608, No.108 Huitong Third Road, Hengqin New Area, Zhuhai, Guangdong, China 519031
 Tel: (+86-756) 8522218 Fax: (+86-756)8669426 E-mail: gree@gree.com.cn <https://global.gree.com>