

SPLIT TYPE **19SEER Charmo R32**

KW24XQ19SDO



Outdoor Unit Model		KW24XQ19SDO	
Outdoor Unit	Compressor Manufacturer	--	ZHUHAI LANDA COMPRESSOR CO. LTD.
	Compressor Model	--	FTz-SM151AXB
	Compressor Oil	--	FW68DA or equivalent
	Compressor Type	--	Rotary
	Compressor LRA.	A	35
	Compressor RLA	A	10
	Compressor Power Input	W	1330
	Compressor Overload Protector	--	HPC 115/95U1 KSD115°C
	Throttling Method	--	Capillary
	Set Temperature Range	°F	61~86
	Cooling Operation Ambient Temperature Range	°F	0~118
	Heating Operation Ambient Temperature Range	°F	-13~75
	Condenser Form	--	Aluminum Fin-copper Tube
	Condenser Pipe Diameter	mm	Φ7
	Condenser Rows-fin Gap	mm	2-1.4
	Condenser Coil Length (LXD _{XW})	mm	839X38.1X616
	Fan Motor Speed	rpm	800
	Fan Motor Power Output	W	50
	Fan Motor RLA	A	1
	Fan Motor Capacitor	μF	3.5
	Outdoor Unit Air Flow Volume	m ³ /h	3200
	Fan Type	--	Axial-flow
	Fan Diameter	mm	Φ520
	Defrosting Method	--	Automatic Defrosting
	Climate Type	--	T1
	Isolation	--	1
	Moisture Protection	--	IPX4
	Permissible Excessive Operating Pressure for the Discharge Side	MPa	4.3
	Permissible Excessive Operating Pressure for the Suction Side	MPa	2.5
	Sound Pressure Level	dB (A)	58
	Sound Power Level	dB (A)	68
	Dimension(WXHXD)	inch	37 23/32X25 63/64X15 53/64
	Dimension of Carton Box (LXWXH)	inch	40 33/64X17 53/64X28 5/32
Dimension of Package(LXWXH)	inch	40 5/8X17 61/64X29 1/64	
Net Weight	lb	93.7	
Gross Weight	lb	103.6	
Refrigerant	--	R32	
Refrigerant Charge	oz	42.3	
Connection Pipe	Connection Pipe Length	ft	24.6
	Connection Pipe Gas Additional Charge	oz/ft.	0.1
	Outer Diameter Liquid Pipe		1/4"
	Outer Diameter Gas Pipe		1/2"
	Max Distance Height	ft	82
	Max Distance Length	ft	131.2
Note: The connection pipe applies metric diameter.			

Job Name:

Schedule Reference:

Date:

Specification are subject to change without notice.

Capacity Variation Ratio According to Temperature

Cooling:

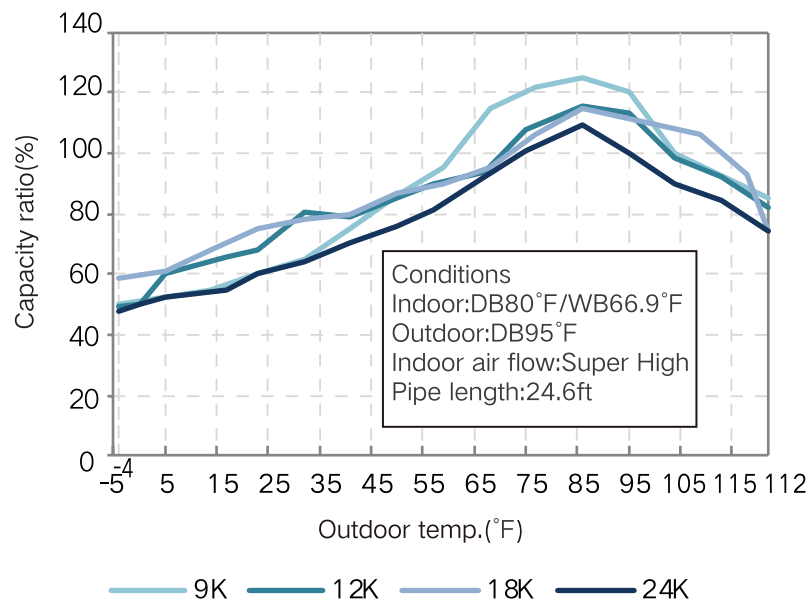

Heating:

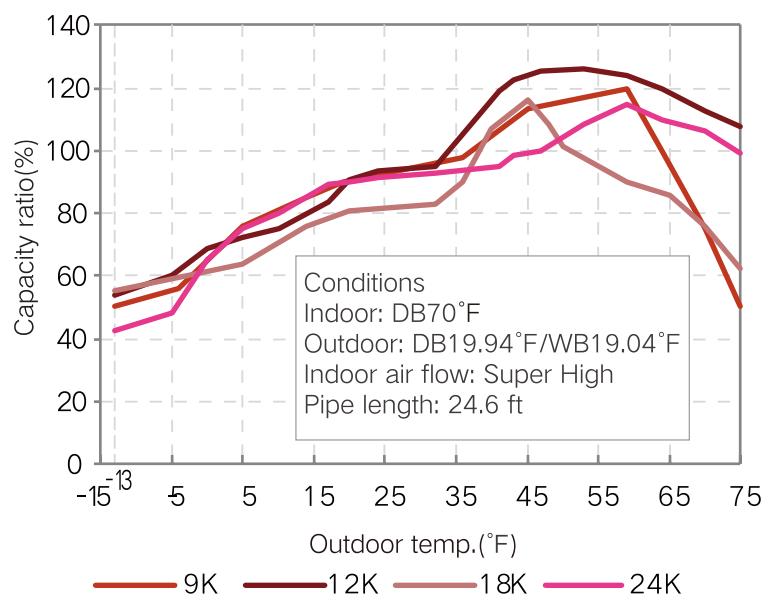

Job Name:

Schedule Reference:

Date:

Indoor Unit

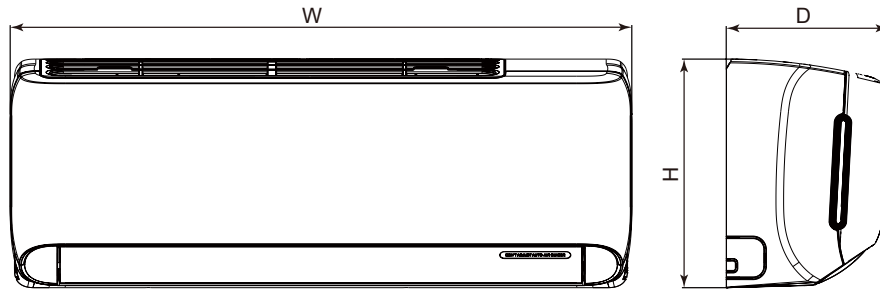

ATE

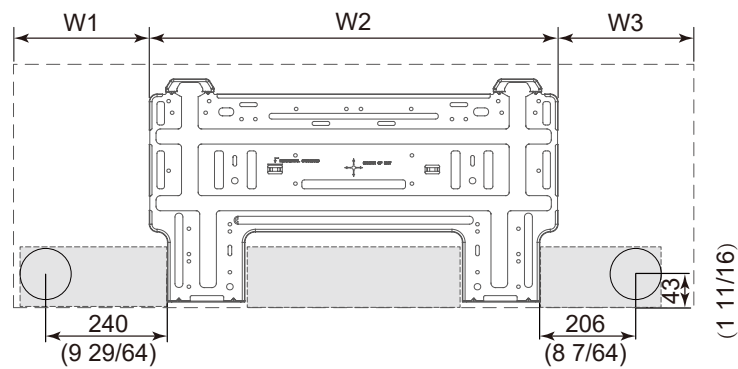

Unit:inch

Model	W	H	D	W1	W2	W3
ATC	42 7/16	13 7/64	9 11/16	6 15/64	22 7/64	10 5/32

Outdoor Unit

XF

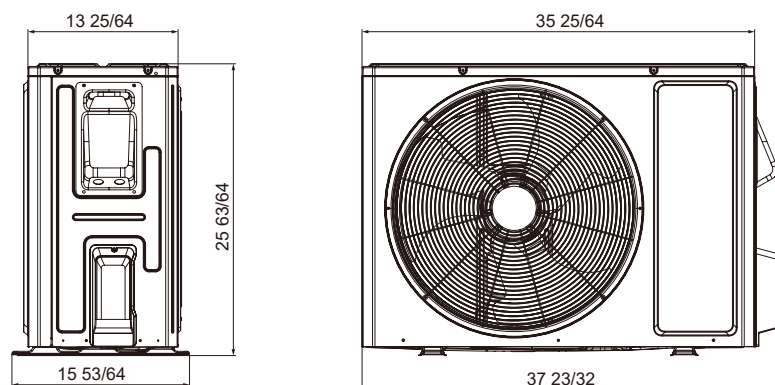

Unit:inch

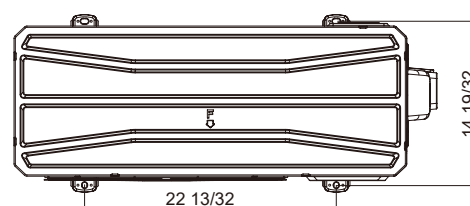

Job Name:

Schedule Reference:

Date:

Installation Dimension Diagram

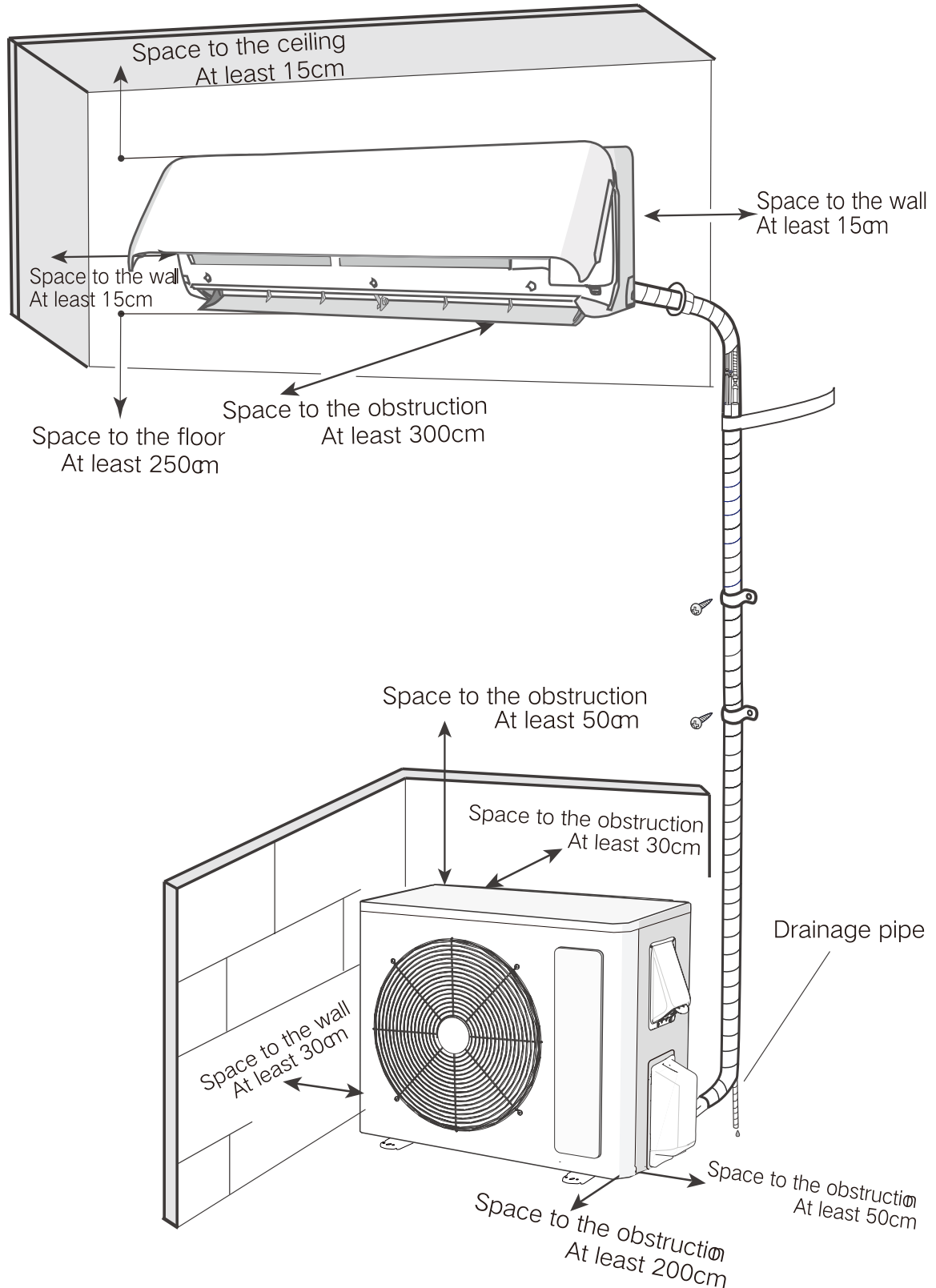

Job Name:

Schedule Reference:

Date:

SPLIT TYPE **19SEER Charmo R32**

KW30XQ21SDI



Model			KW30XQ21SDI
Power Supply	Rated Voltage	V~	208/230
	Rated Frequency	Hz	60
	Phases		1
Power Supply Mode		--	Outdoor
Cooling Capacity		Btu/h	30000
Heating Capacity		Btu/h	30000
Cooling Power Input		W	2750
Heating Power Input		W	2750
Cooling Current Input		A	11.8
Heating Current Input		A	11.7
Rated Input		W	4000
Rated Cooling Current		A	20
Rated Heating Current		A	20
Air Flow Volume		CFM	794/647/618/559/500/471/441
Dehumidifying Volume		Pint/h	7.40
EER		(Btu/h)/W	10.90
COP		(Btu/h)/W	10.90
SEER		--	22(SEER2)
HSPF		--	9(HSPF2)
Application Area		m ²	46-70
Indoor Unit	Model		TWH30AT19D6DI
	Fan Type		Cross-flow
	Fan Diameter Length(DXL)		mm Φ111.5X830
	Cooling Speed		r/min 1450/1150/1100/1000/950/900/850
	Heating Speed		r/min 1450/1200/1100/1050/1000/950/850
	Fan Motor Power Output		W 110
	Fan Motor RLA		A 0.8
	Fan Motor Capacitor		μF /
	Evaporator Form		-- Aluminum Fin-copper Tube
	Evaporator Pipe Diameter		mm Φ7
	Evaporator Row-fin Gap		mm 2-1.2
	Evaporator Coil Length (LXDXW)		mm 840X25.4X381
	Swing Motor Model		-- MP35CP / MP24HF
	Swing Motor Power Output		W 2.5 / 1.5
	Fuse Current		A 3.15
	Sound Pressure Level		dB (A) Cooling:52/45/44/41/39/38/36 Heating:53/45/43/41/39/38/35
	Sound Power Level		dB (A) Cooling:62/55/54/51/49/48/46 Heating:63/55/53/51/49/48/45
	Dimension (WXHxD)		inch 42 7/16X13 7/64X9 11/16
	Dimension of Carton Box (LXWXH)		inch 44 13/32X15 63/64X12 23/32
	Dimension of Package (LXWXH)		inch 44 39/64X16 19/64X13 7/64
Net Weight		lb 34.2	
Gross Weight		lb 40.8	

Job Name:

Schedule Reference:

Date: