



Owner's Manual

Original Instructions

Multi Variable Air Conditioners Cassette Type Indoor Unit

Models:

GMV-ND18T/NhE-T(U)

GMV-ND15T/NhE-T(U)

GMV-ND12T/NhE-T(U)

GMV-ND09T/NhE-T(U)

GMV-ND07T/NhE-T(U)

GMV-ND05T/NhE-T(U)

Thank you for choosing this product. Please read this Owner's Manual carefully before operation and retain it for future reference.

If you have lost the Owner's Manual, please contact the local agent or visit www.gree.com or send an email to global@cn.gree.com for the electronic version.

GREE ELECTRIC APPLIANCES, INC. OF ZHUHAI



To Users

Thank you for selecting Gree product. Please read this instruction manual carefully before installing and using the product, so as to master and correctly use the product. In order to guide you to correctly install and use our product and achieve expected operating effect, we hereby instruct as below:

- (1) This appliance is not intended for use by persons (including children) with reduced physical, sensory or mental capabilities, or lack of experience and knowledge, unless they have been given supervision or instruction concerning use of the appliance by a person responsible for their safety. Children should be supervised to ensure that they do not play with the appliance.
- (2) In order to ensure reliability of product, the product may consume some power under stand-by status for maintaining normal communication of system and preheating refrigerant and lubricant. If the product is not to be used for long, cut off the power supply; please energize and preheat the unit in advance before reusing it.
- (3) Please properly select the model according to actual using environment, otherwise it may impact the using convenience.
- (4) This product can't be installed at corrosive, inflammable or explosive environment or the place with special requirements, such as kitchen. Otherwise, it will affect the normal operation or shorten the service life of the unit, or even cause fire hazard or serious injury. As for above special places, please adopt special air conditioner with anti-corrosive or anti-explosion function.
- (5) If the product needs to be installed, moved or maintained, please contact our designated dealer or local service center for professional support. Users should not disassemble or maintain the unit by themselves, otherwise it may cause relative damage, and our company will bear no responsibilities.
- (6) All the illustrations and information in the instruction manual are only for reference. In order to make the product better, we will continuously conduct improvement and innovation. If there is adjustment in the product, please subject to actual product.







Exception Clauses

Manufacturer will bear no responsibilities when personal injury or property loss is caused by the following reasons:

- (1) Damage the product due to improper use or misuse of the product.
- (2) Alter, change, maintain or use the product with other equipment without abiding by the instruction manual of manufacturer.
- (3) After verification, the defect of product is directly caused by corrosive gas.
- (4) After verification, defects are due to improper operation during transportation of product.
- (5) Operate, repair, maintain the unit without abiding by instruction manual or related regulations.
- (6) After verification, the problem or dispute is caused by the quality specification or performance of parts and components that produced by other manufacturers.
- (7) The damage is caused by natural calamities, bad using environment or force majeure.

Preface

For correct installation and operation, please read all instructions carefully. Understand these signal words: **DANGER**, **WARNING**, **CAUTION** and **NOTICE**. These words are used with the safety--alert symbol.

 DANGER	This is the safety alert symbol. It is used to alert you to potential personal injury hazards. Obey all safety messages that follow this symbol to avoid possible injury or death.
 WARNING	This mark indicates procedures which, if improperly performed, might lead to the death or serious injury of the user.
 CAUTION	This mark indicates procedures which, if improperly performed, might possibly result in personal harm to the user, or damage to property.
NOTICE	NOTICE is used to address practices not related to personal injury.
 Refrigerant Safety Group A2L R32	Appliance filled with flammable gas R32.
	Before install the appliance, read the installation manual first.
	Before use the appliance, read the owner's manual first.
	Before repair the appliance, read the service manual first.

 WARNING	
(1)	Do not use means to accelerate the defrosting process or to clean, other than those recommended by the manufacturer.
(2)	The appliance shall be stored in a room without continuously operating ignition sources (for example: open flames, an operating gas appliance or an operating electric heater).
(3)	Do not pierce or burn.
(4)	Be aware that refrigerants might not contain an odour.

This appliance is not intended for use by persons (including children) with reduced physical, sensory or mental capabilities, or lack of experience and knowledge, unless they have been given supervision or instruction concerning use of the appliance by a person responsible for their safety.

Children should be supervised to ensure that they do not play with the appliance.



DISPOSAL: Do not dispose this product as unsorted municipal waste. Collection of such

■ waste separately for special treatment is necessary.

Contents

1 Safety Notices (Please be sure to abide them)	1
2 Product Introduction	2
2.1 Names of Key Components	2
2.2 Rated Working Condition	3
2.3 The Range of Production Working Temperature	3
2.4 Minimum Room Area	3
2.5 Calculation Method of Releasable Charge (m_{REL})	4
3 Preparations for Installation	6
3.1 Standard Fittings	7
3.2 Installation Position Selection	7
3.3 Requirements for Communication Line	8
3.4 Wiring Requirements and Fuse Capacity	9
4 Installation Instructions	10
4.1 Installation of Indoor Unit	10
4.2 Refrigerant Pipe Connection	13
4.3 Drainage Pipe Installation and Drainage System Testing	14
4.4 Locking Joint Installation	17
4.5 Panel Installation	18
4.6 Installation of Wired Controller	21
5 Wiring Work	21
5.1 Connection of Wire and Patch Board Terminal	22
5.2 Power Cord Connection	22
5.3 Connection of Communication Wire between Indoor Unit and Outdoor Unit (or Indoor Unit)	23
5.4 Connect Communication Wire of Wired Controller	23
5.5 Illuminate for Connection of Wired Controller and Indoor Units Network	24
6 Routine Maintenance	25
6.1 About the Refrigerant Leakage Sensor	25
6.2 Cleaning of Filter	27
6.3 Maintenance before the Seasonal Use	27
6.4 Maintenance after the Seasonal Use	27
7 Table of Error Codes for Indoor Unit	27
8 Troubleshooting	28
9 Unventilated Areas	28
10 Qualification of Worker	29
11 Transportation, Marking and Storage for Units that Employ Flammable Refrigerants	29

11.1 General	29
11.2 Transport of Equipment Containing Flammable Refrigerants	29
11.3 Marking of Equipment Using Signs	29
11.4 Disposal of Equipment Using Flammable Refrigerants	29
11.5 Storage of Equipment/Appliances	30
11.6 Storage of Packed (Unsold) Equipment	30
12 Information on Servicing	30
12.1 General	30
12.2 Checks to the Area	30
12.3 Work Procedure	30
12.4 General Work Area	30
12.5 Checking for Presence of Refrigerant	30
12.6 Presence of Fire Extinguisher	30
12.7 No Ignition Sources	30
12.8 Ventilated Area	31
12.9 Checks to the Refrigerating Equipment	31
12.10 Checks to Electrical Devices	31
12.11 Pipe Installation	32
13 Sealed Electrical Components shall be Replaced	32
14 Intrinsically Safe Components must be Replaced	32
15 Cabling	32
16 Detection of Flammable Refrigerants	32
17 Removal and Evacuation	33
18 Charging Procedures	33
19 Decommissioning	34
20 Labeling	34
21 Recovery	35

1 Safety Notices (Please be sure to abide them)

⚠ WARNING	
(1)	This product can't be installed at corrosive, inflammable or explosive environment or the place with special requirements, such as kitchen. Otherwise, it will affect the normal operation or shorten the service life of the unit, or even cause fire hazard or serious injury. As for the above special places, please adopt special air conditioner with anti-corrosive or anti-explosion function.
(2)	Follow this manual to complete the installation work. Please read this manual carefully before turning on or repairing the unit.
(3)	Installation should be conducted by the dealer or qualified personnel. Please do not attempt to install the air conditioner by yourself. Improper installation may lead to water leakage, electric shock or fire hazard, etc.
(4)	Before installation, please check whether the power supply is complied with that specified on the nameplate and check the safety of the power supply.
(5)	The air conditioner must be grounded reliably for avoiding electric shock. Please do not connect the earthing wire to gas pipe, water pipe, lightning rod or telephone line.
(6)	Be sure to use special accessories and parts for installation to prevent water leakage, electric shock and fire hazard, etc.
(7)	If refrigerant leakage happens, please ventilate the room immediately.
(8)	Diameter of power cord should be large enough. The damaged power cord and connection wire must be replaced with special cables.
(9)	When the power cord is connected, please fix the electric box cover properly to avoid safety accidents.
(10)	Never fail to comply with the nitrogen-charging welding process. Do charge nitrogen when welding the pipes.
(11)	Never short circuit or cancel the pressure switch to prevent unit damage.
(12)	As for the unit controlled by the wired controller, connect the wired controller well firstly and then energize the unit; otherwise, the unit can't operate normally.
(13)	When installation is finished, please check whether the drainage pipes, pipelines and electric wires are connected correctly to avoid water leakage, refrigerant leakage, electric shock or fire, etc.
(14)	Do not insert fingers or objects into air outlet or air return grille.
(15)	Open the door and window frequently to keep good ventilation for avoiding oxygen deficit when gas heater or oil heater is used in the room.
(16)	Never plug in or unplug the power plug directly to turn on or turn off the air conditioner.
(17)	Once the air conditioner is turned on, it can be turned off only after it has operated for 5min at least; otherwise, it will affect the oil return of compressor.
(18)	Do not allow children to operate this air conditioner.
(19)	Do not operate this air conditioner with wet hands.
(20)	The air conditioner can be cleaned only when it has been turned off and the power has been cut off; otherwise, it may cause electric shock or injury.
(21)	Never spray or flush water towards the air conditioner; otherwise, malfunction or electric shock may happen.
(22)	Do not expose the air conditioner to the moist or corrosive environment.
(23)	Put through the power 8 hours in advance before operation. Do not cut off the power when the air conditioner stops operation for only about one night (protect the compressor).
(24)	Volatile liquid, such as diluent or gasoline, will damage the appearance of air conditioner. Only soft dry cloth and wet cloth dipped with neutral detergent can be used to clean the outer case of air conditioner.
(25)	Under cooling mode, please don't set the room temperature too low; keep the temperature difference between indoor and outdoor within 5°C (41°F).
(26)	If there are any abnormal circumstances (such as burning smell, etc.), please turn off the unit and cut off the main power supply immediately, and then contact our designated dealer or local service center. If those abnormal circumstances still exist, the unit may be damaged and it may lead to electric shock or fire hazard.
(27)	Do not repair the unit by yourself. Wrong maintenance may cause electric shock or fire hazard. Please contact our designated dealer or local service center for help.

⚠ WARNING

- | |
|---|
| (28) LEAK DETECTION SYSTEM installed. Unit must be powered except for service. |
| (29) This unit is equipped with a refrigerant leak detector for safety. To be effective, the unit must be electrically powered at all times after installation, other than when servicing. |
| (30) Ducts connected to an appliance shall not contain a potential ignition source. |
| (31) Keep any required ventilation openings clear of obstruction. |
| (32) Precautions shall be taken to avoid excessive vibration or pulsation to refrigerating piping. |
| (33) Protection devices, piping and fittings shall be protected as far as possible against adverse environmental effects, for example the danger of water collecting and freezing in relief pipes or the accumulation of dirt and debris. |
| (34) Provision shall be made for expansion and contraction of long runs of piping. |
| (35) Piping in refrigerating systems shall be so designed and installed as to minimize the likelihood of hydraulic shock damaging the system. |
| (36) Steel pipes and components shall be protected against corrosion with a rustproof coating before applying any insulation. |
| (37) Only auxiliary devices approved by the appliance manufacturer or declared suitable with the refrigerant shall be installed in connecting ductwork. |

If the product needs to be installed, moved or maintained, please contact our designated dealer or local service center for professional support, otherwise our company would bear no legal liability for the related damages arising therefrom.

2 Product Introduction

2.1 Names of Key Components

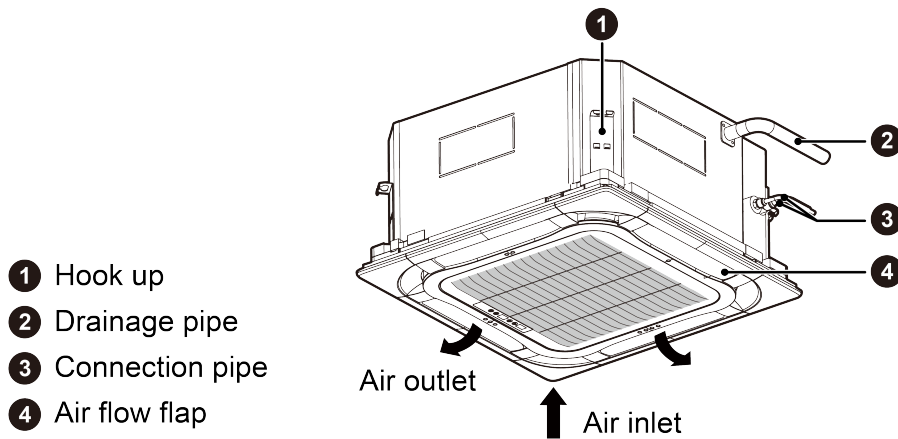

Fig.2.1.1

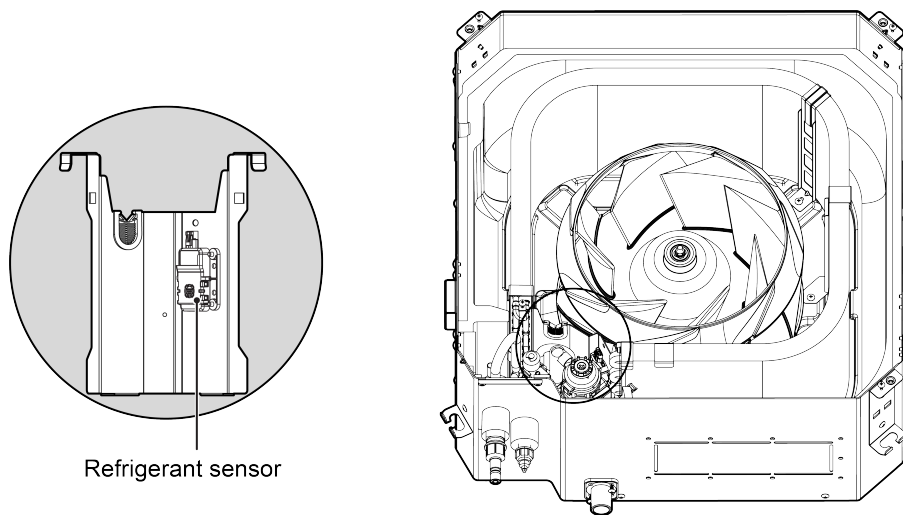

Fig.2.1.2

2.2 Rated Working Condition

—	Indoor Side Condition		Outdoor Side Condition	
	Dry Bulb Temp °C(°F)	Wet Bulb Temp °C(°F)	Dry Bulb Temp °C(°F)	Wet Bulb Temp °C(°F)
Rated Cooling	26.7(80.0)	19.4(67.0)	35(95.0)	23.9(75.0)
Rated Heating	21.1(70.0)	15.6(60.0)	8.3(47.0)	6.1(43.0)

2.3 The Range of Production Working Temperature

—	Cooling	Heating
Indoor temperature	14°C(57.2°F)~25°C(77°F)WB	15°C(59°F)~27°C(80.6°F)DB
Indoor humidity	≤80%	

2.4 Minimum Room Area

Area of the room where the indoor unit is installed must meet the minimum room area in the following table:

Releasable Charge (kg)	Minimum Room Area (m ² / ft ²)					
	H ₀ ≥2.2m					
	H=2.2m	H=2.5m	H=3m	H=3.5m	H=4m	H=5m
2.0	6.0 / 64.0	5.3 / 56.3	4.4 / 47	3.8 / 40.3	3.3 / 35.2	2.7 / 28.2
2.2	6.6 / 70.4	5.8 / 62.0	4.8 / 51.6	4.2 / 44.3	3.6 / 38.7	2.9 / 31
2.4	7.2 / 76.8	6.3 / 67.6	5.3 / 56.3	4.5 / 48.3	4 / 42.3	3.2 / 33.8
2.6	7.8 / 83.2	6.8 / 73.2	5.7 / 61	4.9 / 52.3	4.3 / 45.8	3.4 / 36.6
2.8	8.4 / 89.6	7.4 / 78.8	6.2 / 65.7	5.3 / 56.3	4.6 / 49.3	3.7 / 39.4
3.0	9.0 / 96.0	7.9 / 84.5	6.6 / 70.4	5.7 / 60.4	5 / 52.8	4 / 42.3
3.2	9.6 / 102.4	8.4 / 90.1	7 / 75.1	6 / 64.4	5.3 / 56.3	4.2 / 45.1
3.4	10.2 / 108.8	8.9 / 95.7	7.5 / 79.8	6.4 / 68.4	5.6 / 59.8	4.5 / 47.9
3.6	10.7 / 115.2	9.5 / 101.4	7.9 / 84.5	6.8 / 72.4	5.9 / 63.4	4.8 / 50.7
3.8	11.3 / 121.6	10.0 / 107.0	8.3 / 89.2	7.1 / 76.4	6.3 / 66.9	5 / 53.5
4.0	11.9 / 128.0	10.5 / 112.6	8.8 / 93.9	7.5 / 80.5	6.6 / 70.4	5.3 / 56.3
4.2	12.5 / 134.4	11.0 / 118.2	9.2 / 98.5	7.9 / 84.5	6.9 / 73.9	5.5 / 59.1
4.4	13.1 / 140.8	11.6 / 123.9	9.6 / 103.2	8.3 / 88.5	7.2 / 77.4	5.8 / 62
4.6	13.7 / 147.2	12.1 / 129.5	10.1 / 107.9	8.6 / 92.5	7.6 / 81	6.1 / 64.8
4.8	14.3 / 153.5	12.6 / 135.1	10.5 / 112.6	9 / 96.5	7.9 / 84.5	6.3 / 67.6

Releasable Charge (kg)	Minimum Room Area (m ² / ft ²)					
	H ₀ ≥2.2m					
	H=2.2m	H=2.5m	H=3m	H=3.5m	H=4m	H=5m
5.0	14.9 / 159.9	13.1 / 140.8	10.9 / 117.3	9.4 / 100.6	8.2 / 88	6.6 / 70.4
5.2	15.5 / 166.3	13.6 / 146.4	11.4 / 122	9.8 / 104.6	8.5 / 91.5	6.8 / 73.2
5.4	16.1 / 172.7	14.2 / 152.0	11.8 / 126.7	10.1 / 108.6	8.9 / 95	7.1 / 76
5.6	16.7 / 179.1	14.7 / 157.6	12.3 / 131.4	10.5 / 112.6	9.2 / 98.5	7.4 / 78.8
5.8	17.3 / 185.5	15.2 / 163.3	12.7 / 136.1	10.9 / 116.6	9.5 / 102.1	7.6 / 81.7
6.0	17.9 / 191.9	15.7 / 168.9	13.1 / 140.8	11.3 / 120.7	9.9 / 105.6	7.9 / 84.5
6.2	18.5 / 198.3	16.3 / 174.5	13.6 / 145.4	11.6 / 124.7	10.2 / 109.1	8.2 / 87.3
6.4	19.1 / 204.7	16.8 / 180.2	14 / 150.1	12 / 128.7	10.5 / 112.6	8.4 / 90.1
6.6	19.7 / 211.1	17.3 / 185.8	14.4 / 154.8	12.4 / 132.7	10.8 / 116.1	8.7 / 92.9
6.8	20.3 / 217.5	17.8 / 191.4	14.9 / 159.5	12.7 / 136.7	11.2 / 119.6	8.9 / 95.7
7.0	20.8 / 223.9	18.4 / 197.0	15.3 / 164.2	13.1 / 140.8	11.5 / 123.2	9.2 / 98.5
7.2	21.4 / 230.3	18.9 / 202.7	15.7 / 168.9	13.5 / 144.8	11.8 / 126.7	9.5 / 101.4
7.4	22.0 / 236.7	19.4 / 208.3	16.2 / 173.6	13.9 / 148.8	12.1 / 130.2	9.7 / 104.2
7.6	22.6 / 243.1	19.9 / 213.9	16.6 / 178.3	14.2 / 152.8	12.5 / 133.7	10 / 107

NOTICE

- (1) H₀ is the release height, H_{inst} is the installation height, H₀ is higher than H_{inst}.
- (2) H is the floor-to-ceiling height of the room.
- (3) If the actual releasable charge is not exactly equal to the value in the table, the larger releasable charge in the table need to be taken.
- (4) If the actual H is not exactly equal to the value in the table, the smaller H in the table need to be taken.
- (5) This manual is only applicable to a single room.
- (6) Correct the minimum room area of the space A_{min} by multiplying by an altitude adjustment factor (AF) based on for building site ground level altitude (Halt) in meters.

Halt	0	200	400	600	800	1000	1200	1400	1600
AF	1.00	1.00	1.00	1.00	1.02	1.05	1.07	1.10	1.12
Halt	1600	1800	2000	2200	2400	2600	2800	3000	3200
AF	1.12	1.15	1.18	1.21	1.25	1.28	1.32	1.36	1.40

- (7) The minimum airflow is 240m³ /h.
- (8) LEAK DETECTION SYSTEM installed. Unit must be powered except for service.

2.5 Calculation Method of Releasable Charge (m_{REL})

The matching outdoor unit is equipped with automatic refrigerant cut-off valves. When the indoor unit detects refrigerant leakage, the cut-off valves will cut off the refrigerant of the outdoor unit. The releasable charge (m_{REL}) refers to the total amount of refrigerant remaining in all indoor units and pipeline that may leak into the room.

$$m_{REL} = m_1 \text{ of all indoor units in the system} + m_2 \text{ of all pipeline in the system} + 0.204\text{kg}$$

If the calculated m_{REL} is larger than the system refrigerant amount (including the default refrigerant of outdoor unit and the additional refrigerant charge), the system refrigerant amount should be used as m_{REL}.

m₁ of cassette type indoor unit is shown in the following table. m₁ of other indoor units refer to

corresponding Owner's Manual.

Unit: kg

Indoor Unit	m1 of single indoor unit
GMV-ND18T/NhE-T(U)	0.4
GMV-ND15T/NhE-T(U)	
GMV-ND12T/NhE-T(U)	
GMV-ND09T/NhE-T(U)	
GMV-ND07T/NhE-T(U)	
GMV-ND05T/NhE-T(U)	

All pipelines in the system are divided into three types A/B/C according to pipe dimension. Count the total pipe length of each type and find out m2 of corresponding type in the table below. Add up all m2 of each type to obtain the m2 of the system.

m2 of pipeline:

Unit: kg

Pipe Type	A	B	C	
Gas Pipe mm (inch)	15.9 (5/8)	12.7 (1/2)	9.52 (3/8)	
Liquid Pipe mm (inch)	9.52 (3/8)	6.35 (1/4)	6.35 (1/4)	
Total Pipe Length m (feet)	5 (16-3/8)	0.27	0.11	0.10
	10 (32-13/16)	0.54	0.22	0.20
	15 (49-3/16)	0.80	0.33	0.29
	20 (65-5/8)	1.07	0.43	0.39
	25 (82)	1.33	0.54	0.49
	30 (98-7/16)	1.60	0.65	0.58
	35 (114-13/16)	1.87	0.75	0.68
	40 (131-1/4)	2.13	0.86	0.78
	45 (147-5/8)	2.40	0.97	0.87
	50 (164-1/16)	2.66	1.07	0.97
	55 (180-7/16)	2.93	1.18	1.07
	60 (196-7/8)	3.20	1.29	1.16
	65 (213-1/4)	3.46	1.39	1.26
	70 (229-11/16)	3.73	1.50	1.36
	75 (246-1/16)	3.99	1.61	1.45
	80 (262-7/16)	4.26	1.71	1.55
	85 (278-7/8)	4.53	1.82	1.65
	90 (295-1/4)	4.79	1.93	1.74
95 (311-11/16)	5.06	2.03	1.84	
100 (328-1/16)	5.32	2.14	1.93	

NOTICE

If the actual pipe length is not exactly equal to the value in the table, the longer length in the table need to be taken.

For example:

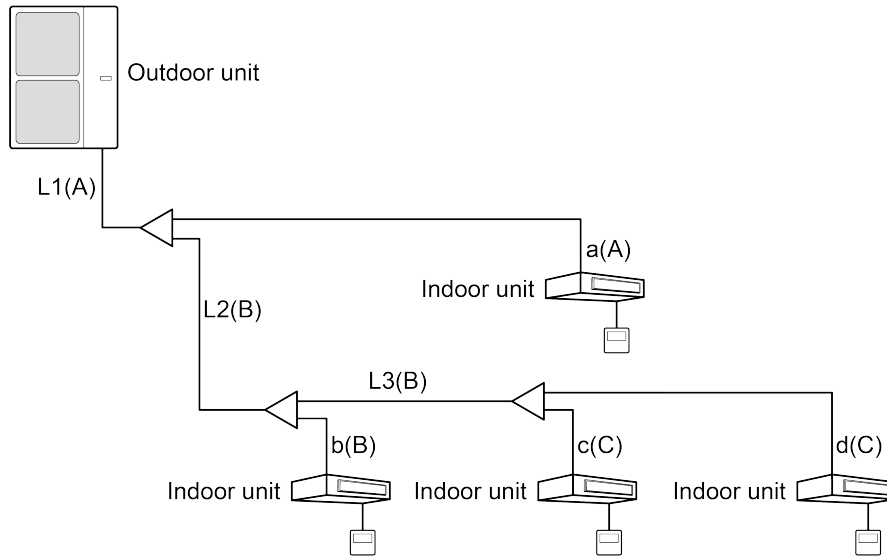

Fig.2.5.1

There are four indoor units in the system: GMV-ND18T/NhE-T(U)*4.

The total length of type A pipeline L1+a is 20m. m² of type A is 1.07kg.

The total length of type B pipeline L2+L3+b+c+d is 40m. m² of type B is 0.86kg.

The total length of type C pipeline is 0m. m² of type C is 0kg.

The system refrigerant amount is 5kg.

The releasable charge (m_{REL}) should be calculated as below:

$$m_1 = 0.4 * 4 = 1.60 \text{ kg}$$

$$m_2 = 1.07 + 0.86 + 0 = 1.93 \text{ kg}$$

$$m_{REL} = 1.60 \text{ kg} + 1.93 \text{ kg} + 0.204 \text{ kg} = 3.734 \text{ kg}$$

For 3 meters high room, the room area must not less than 8.3m²(89.2ft²). If the room area is less than 8.3m²(89.2ft²), measures need to be taken to make the room area meet the requirements, such as changing the piping design of the system to reduce the m_{REL}.











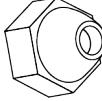

3 Preparations for Installation

NOTICE Product graphics are only for reference. Please refer to actual products.

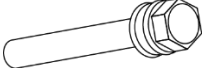
Unspecified measure unit is mm (inch).

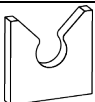
3.1 Standard Fittings

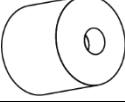
Please use the supplied standard fittings listed below as instructed.

No.	Name	Appearance	Q'ty	Usage
1	Remote controller		1+2	To control the indoor unit.
2	Drainage hose assembly		1	To connect the drainage pipe.
3	Special Nut		2	To be used for connecting the refrigerant pipe.
4	Insulation		1	To insulate the gas pipe.
5	Insulation		1	To insulate the liquid pipe.
6	Flannelette		1	To prevent the communication wire from reaching out the electric raceway.
7	Fastener(300mm)		1	To fasten the sponge.
8	Bolt sub-assy		4	Fix the panel.
9	Sponge		4	To insulate the drain pipe.
10	Gasket Mounting Board		1	Used to prevent gasket from falling off.
11	Fastener(200mm)		4	To fasten the sponge.
12	Bolt with Washer		4	To fix the installation paperboard on the unit.
13	Enswathement		2	Used for winding the pipe connecting the indoor and outdoor units.
14	Washer		10	To be used together with the hanger bolt for installing the unit.

3.2 Installation Position Selection

- (1) The appliance shall not be installed in the laundry.
- (2) The location should be able to withstand the weight of unit.
- (3) The water can be drained conveniently from drainage pipe.
- (4) There should be no obstruction near air inlet and air outlet.
- (5) Follow the installation distance required in the fig below to ensure sufficient space for maintenance.
- (6) The installation location should be far from heat sources, flammable or explosive gas, or smog spread in the air.
- (7) The indoor unit, outdoor unit, power cord and connection electricity wire should be at least 1m (3-1/4ft.) from television and radio in order to prevent interference and noise (Even though 1m (3-1/4ft.) distance is ensure, there may be noise if the electric wave is too strong).

Unit: mm (inch)

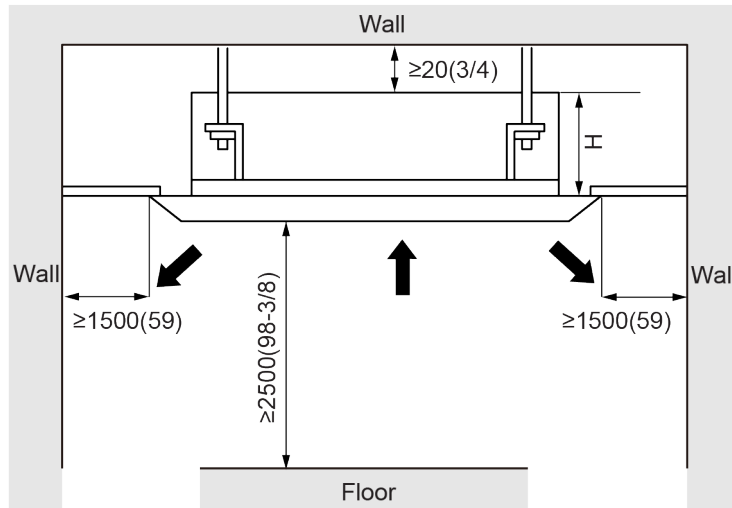

Fig.3.2.1

Unit: mm (inch)

Model	H
GMV-ND18T/NhE-T(U)	305(12)
GMV-ND15T/NhE-T(U)	
GMV-ND12T/NhE-T(U)	
GMV-ND09T/NhE-T(U)	
GMV-ND07T/NhE-T(U)	
GMV-ND05T/NhE-T(U)	

NOTICE

- (1) The unit shall be installed in accordance with national standards or local regulations.
- (2) Only qualified personnel can carry out installation work, please contact with local dealer before installation.
- (3) Make sure all the installation work completed before energizing.
- (4) The appliances are not accessible to general public.

3.3 Requirements for Communication Line

NOTICE If air conditioner used under strong electronic-magnetic interference circumstance, STP (shielded twisted pair) communication cable must be adopted.

3.3.1 Select Communication Line for Indoor Unit and Wired Controller

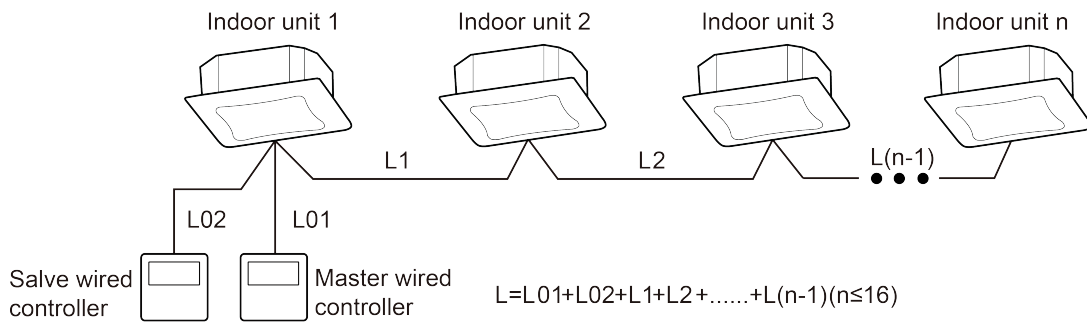

Fig.3.3.1

Multi Variable Air Conditioners Cassette Type Indoor Unit

Material Type	Total Length of Communication Line Between Indoor Unit And Wired Controller L (m/ft.)	Wire Size (AWG)	Remarks
Light/Ordinary polyvinyl chloride sheathed cord.	$L \leq 250$ ($L \leq 820$)	$2 \times \text{AWG}18$ $\sim 2 \times \text{AWG}16$	<ol style="list-style-type: none"> Total length of communication line can't exceed 250m (820ft.). The average length of the communication line between indoor unit and wired controller is 15m(49ft). The cord shall be Circular cord (The cores shall be twisted together.). If unit is installed in places with intense magnetic field or strong interference, it is necessary to use shielded wire.

3.3.2 Selection of Communication Wire between Indoor Unit and Indoor Unit (or Outdoor Unit)

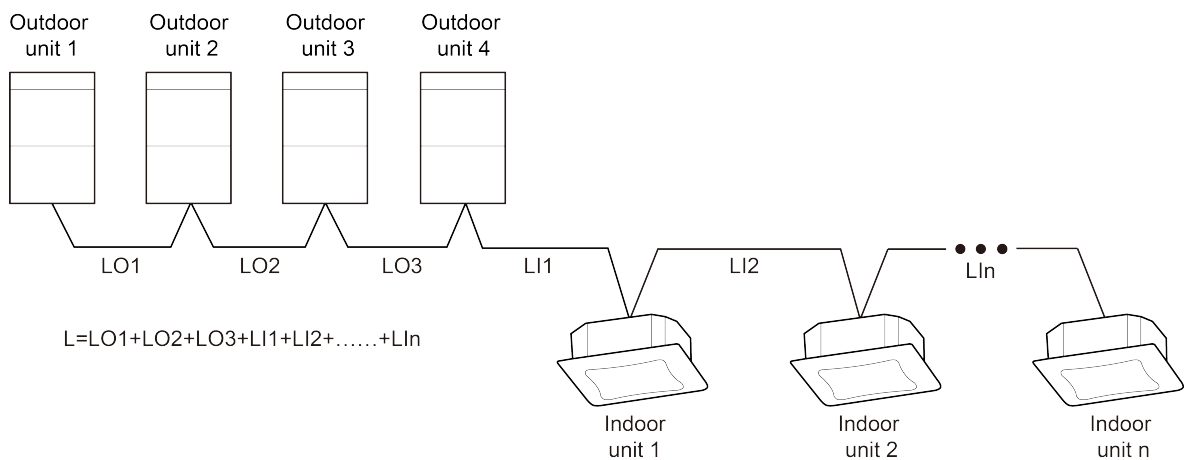

Fig.3.3.2

Material Type	Total Length L (m/ft.) of Communication Line Between Indoor Unit And Indoor (Outdoor)	Wire Size (AWG)	Remarks
Light/Ordinary polyvinyl chloride sheathed cord.	$L \leq 1000$ ($L \leq 3280$)	$\geq 2 \times \text{AWG}18$	<ol style="list-style-type: none"> If the wire diameter is enlarged to $2 \times \text{AWG}16$, the total communication line length can reach 1500m (4920ft.). The average length of communication line between units is 12.5 m(41ft). The cord shall be Circular cord (The cores shall be twisted together). If unit is installed in places with intense magnetic field or strong interference, it is necessary to use shielded wire.

3.4 Wiring Requirements and Fuse Capacity

Power Cord Size and Air Switch Capacity and Fuse Capacity

Model	Power Supply	MCA(A)	MOP(A)
GMV-ND18T/NhE-T(U)	208/230V-1ph-60Hz	0.5	15
GMV-ND15T/NhE-T(U)			
GMV-ND12T/NhE-T(U)			
GMV-ND09T/NhE-T(U)			
GMV-ND07T/NhE-T(U)			
GMV-ND05T/NhE-T(U)			

NOTICE

- | |
|---|
| (1) Fuse is located on the main board. |
| (2) An all-pole disconnection switch having a contact separation of at least 3mm (1/8 inch) in all poles should be connected in fixed wiring. |
| (3) The circuit breaker and power cord specification in above sheet is based on max power (max current) of the unit. |
| (4) The power cord specification in above sheet is based on ambient temperature of 40°C(104°F). |
| (5) The circuit breaker specification in above sheet is based on ambient temperature of 40°C(104°F). If the working condition is different, please adjust it according to the specification sheet of circuit breaker. |
| (6) Continuous air circulation required for proper functioning. Unit must be powered except for service. |

4 Installation Instructions

⚠ WARNING All phases of this installation must conform to NATIONAL, STATE AND LOCAL CODES. If it is required for additional information, please contact your local distributor.

⚠ WARNING A brazed, welded, or mechanical connection shall be made before opening the valves to permit refrigerant to flow between the REFRIGERATING SYSTEM parts. A vacuum valve shall be provided to evacuate the interconnecting pipe or any uncharged REFRIGERATING SYSTEM part.

NOTICE These cassette type indoor units are limited to be installed for one room.

4.1 Installation of Indoor Unit**4.1.1 Ceiling Opening Dimension and Suspension Bolt Position.**

Unit: mm (inch)

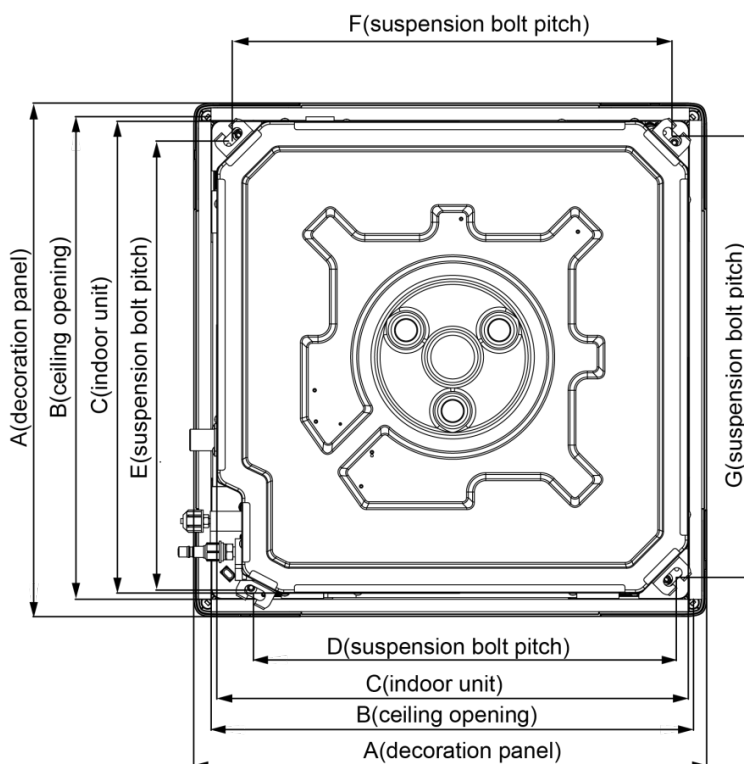

Fig.4.1.1

Unit: mm (inch)

Model	A	B	C	D	E	F	G
GMV-ND18T/NhE-T(U)	620 (24-3/8)	580 (22-13/16)	570 (22-7/16)	505 (19-7/8)	550 (22-5/8)	530 (20-7/8)	530 (20-7/8)
GMV-ND15T/NhE-T(U)							
GMV-ND12T/NhE-T(U)							
GMV-ND09T/NhE-T(U)							
GMV-ND07T/NhE-T(U)							
GMV-ND05T/NhE-T(U)							

⚠ WARNING The drilling work and installation of unit must be carried out by qualified personnel.

4.1.2 Suspend the Indoor Unit

(1) Drill bolt holes and install bolts.

- 1) Stick the reference cardboard on the installation position; drill 4 holes according to the hole site on the cardboard as shown in Fig.4.1.2; Diameter of drilling hole is according to the diameter of expansion bolt and the depth is 60-70mm (2-3/8~2-3/4 inch), as shown in Fig.4.1.3.

Unit: mm (inch)

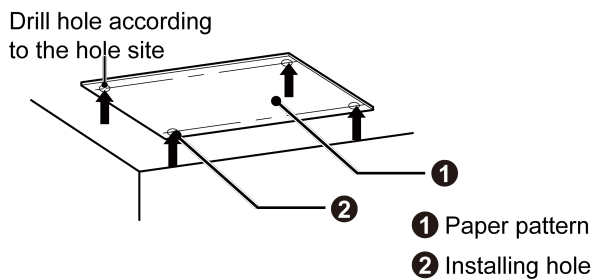

Fig.4.1.2

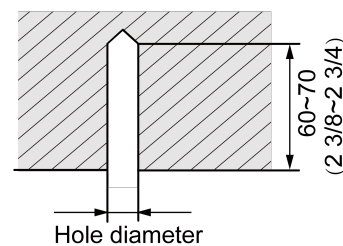

Fig.4.1.3

- 2) Insert the M10 expansion bolt into the hole and then knock the nail into the bolt, as shown in Fig.4.1.4.

NOTICE The length of bolt depends on the installation height of the unit, bolts are field supplied.

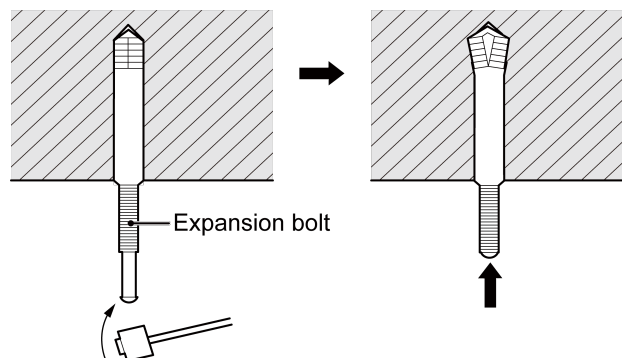

Fig.4.1.4

(2) Install the indoor unit temporarily.

Assemble suspension bolt on the expansion bolt, attach the hanger bracket to the suspension bolt. Be sure to fix it securely by using a nut and washer from upper and lower sides of the hanger

bracket. The washer fixing plate will prevent the washer from falling.

(3) The usage of paper pattern.

Refer to paper pattern of installation for ceiling opening dimension. The center of ceiling opening is indicated on the paper pattern. Fix the paper pattern to the unit with 4 screws and fix the corners of the waterspout at the drainage pipe by screws.

(4) Adjust the unit to the right position.

(5) Check the level of the unit.

The indoor unit is equipped with build-in water pump and float switch, verify the levelness of 4 directions by level gauge or vinyl tube (filled with water) respectively.

(6) Remove the washer locating plate and then tighten the nut on it.

(7) Remove the paper pattern.

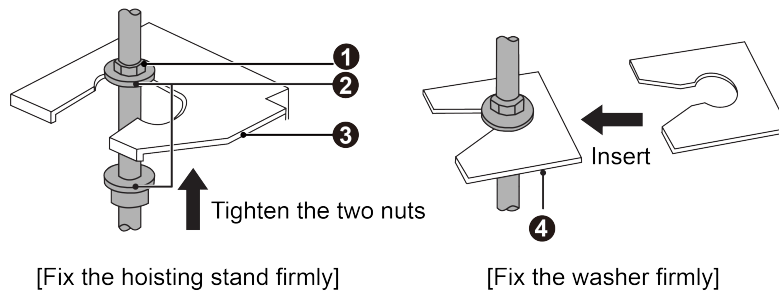

- ① Nut(field supplied)
- ② Washer(provided)
- ③ Hoisting stand
- ④ Washer fixing plate(provided)

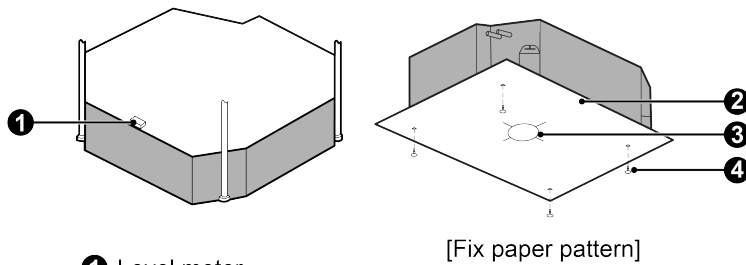

- ① Level meter
- ② Paper pattern
- ③ Center of ceiling opening
- ④ Screw(provided)

Fig.4.1.5

4.2 Refrigerant Pipe Connection

- (1) Aim the flaring port of copper pipe at the center of screwed joint and then tighten the flaring nut with hand as shown in Fig.4.2.1.
- (2) Tighten the flaring nut with torque wrench.

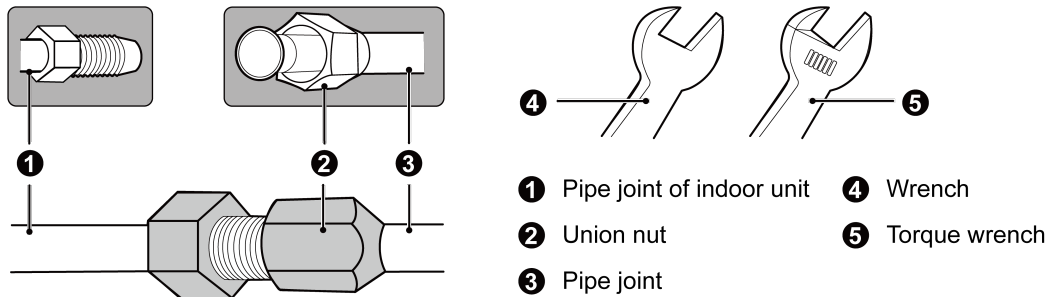

Fig.4.2.1

Pipe Diameter mm(inch)	Torque(N·m)
Φ6.35(1/4)	15~30
Φ9.52(3/8)	35~40
Φ12.7(1/2)	45~50
Φ15.9(5/8)	60~65

- (3) Use pipe bend when bending the pipe and the bending angle should not be too small.
- (4) Wrap the connection pipe and joint with sponge and then tie them firmly with tape.

⚠ WARNING

- (1) Mechanical connectors used indoors shall comply with ISO 14903. When mechanical connectors are reused indoors, sealing parts shall be renewed.
- (2) Pipework shall be protected from physical damage.
- (3) Installation of pipework shall be kept to a minimum space required.
- (4) Do not re-use joints and copper gaskets which have been used already.
- (5) Joints made in installation between parts of refrigerant system shall be accessible for maintenance purposes.
- (6) Install the refrigerant piping or components in a position where they are unlikely to be exposed to any substance which may corrode components containing refrigerant, unless the components are constructed of materials that are inherently resistant to corrosion or are suitably protected against corrosion.
- (7) That after completion of field piping for split systems, the field pipework shall be pressure tested with an inert gas and then vacuum tested prior to refrigerant charging, according to the following requirements field-made refrigerant joints indoors shall be tightness tested. The test method shall have a sensitivity of 5 grams per year of refrigerant or better under a pressure of at least 0.25 times the maximum allowable pressure. No leak shall be detected.

4.3 Drainage Pipe Installation and Drainage System Testing

4.3.1 Notice for Installation of Drain Pipe

- (1) It is not allowed to connect the condensate drain pipe into waste pipe or other pipelines which are likely to produce corrosive or peculiar smell to prevent the smell from entering indoors or corrupt the unit.
- (2) It is not allowed to connect the condensate drain pipe into rain pipe to prevent rain water from pouring in and cause property loss or personal injury.
- (3) Condensate drain pipe should be connected into special drain system for air conditioner.
- (4) The drainage pipe should be short and the gradient downwards should be at least 1%~2% in order to drain condensation water smoothly.
- (5) The diameter of drainage hose should be bigger or equal to the diameter of drainage pipe joint.
- (6) Install drainage pipe according to the following Fig.4.3.1 and arrange insulation to the drainage pipe. Improper installation may lead to water leakage and damp the furniture and other things in the room.
- (7) You can buy normal hard PVC pipe used as the drainage pipe. During connection, insert the end of PVC pipe into the drainage hole and then tighten it with drainage hole and wire binder. Can't connect the drainage hole and drainage hole with glue.
- (8) When the drainage pipelines are used for several units, the position of pipeline should be about 100mm (4 inch) lower than the drainage port of each unit. In this case, thicker pipes should be applied.

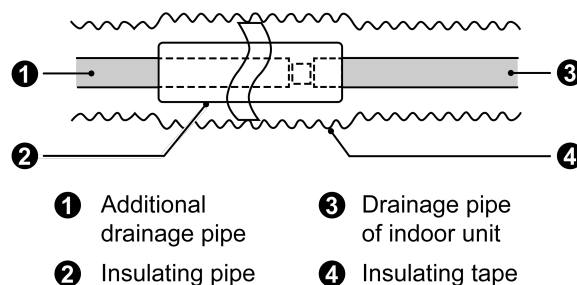

Fig.4.3.1

4.3.2 Drainage Pipe Installation

- (1) Drainage pipe should have the same diameter or larger diameter than the connecting pipes (PVC pipe, outside diameter 25mm (1 inch), thickness \geq 1.5mm (1/16 inch)).
- (2) Keep drainage pipe short and sloping downwards at a gradient of at least 1% for preventing forming air bubbles.
- (3) If the gradient of drainage pipe could not meet the installation requirements, raising pipe should be applied.
- (4) Insert the drainage hose into drain socket, tighten the metal clamp securely.
- (5) Warp the sealing pad over drain hose and metal clamp for heat insulation.
- (6) Make sure to perform insulation work for all drainage piping in order to prevent any possible water drop due to dew condensation.

- (7) Apply the suitable diameter for converging drainage pipe according to the operating capacity of the unit.

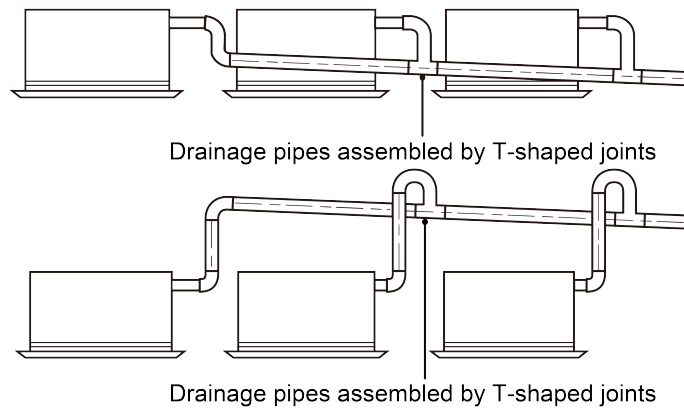

Fig.4.3.2

- (8) The horizontal pipe can't be connected to vertical pipe in the same level; please select the connection way as shown in following figure.

- 1) Three-way connection of drainage pipe joints (Fig.4.3.3).
- 2) Connection of downspout elbow (Fig.4.3.4).
- 3) Inserting horizontal pipe connection (Fig.4.3.5).

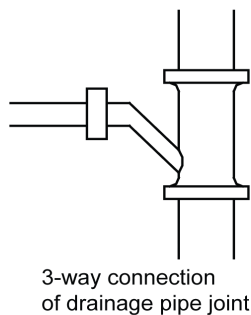

Fig.4.3.3

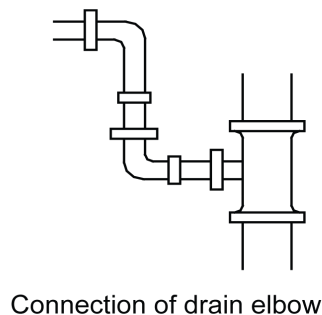

Fig.4.3.4

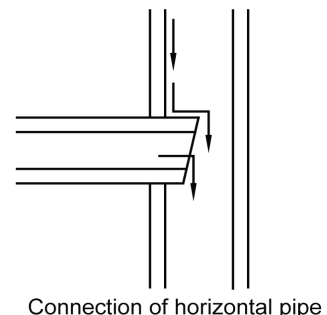

Fig.4.3.5

- (9) Drain pipes should have a downward slope of at least 1%~2%, in order to prevent pipes from sagging, install hanger bracket at intervals of 1000~1500mm (39-3/8~59 inch).

Unit: mm (inch)

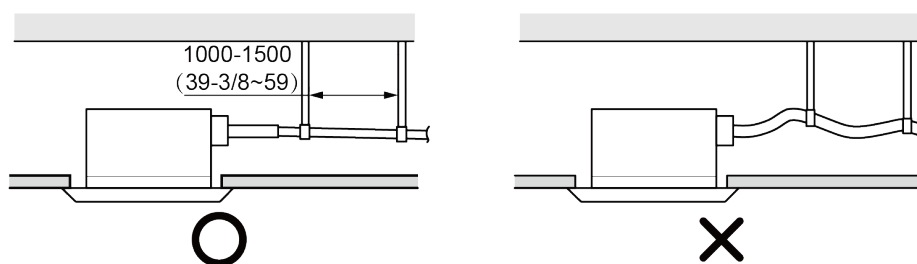

Fig.4.3.6

- (10) The installation height of raising pipe for drainage should be lower than B. The gradient from raising pipe towards drainage direction should be at least 1%~2%. If the raising pipe is vertical with the unit, the raising height should be less than C, as shown in Fig.4.3.7.

Unit: mm (inch)

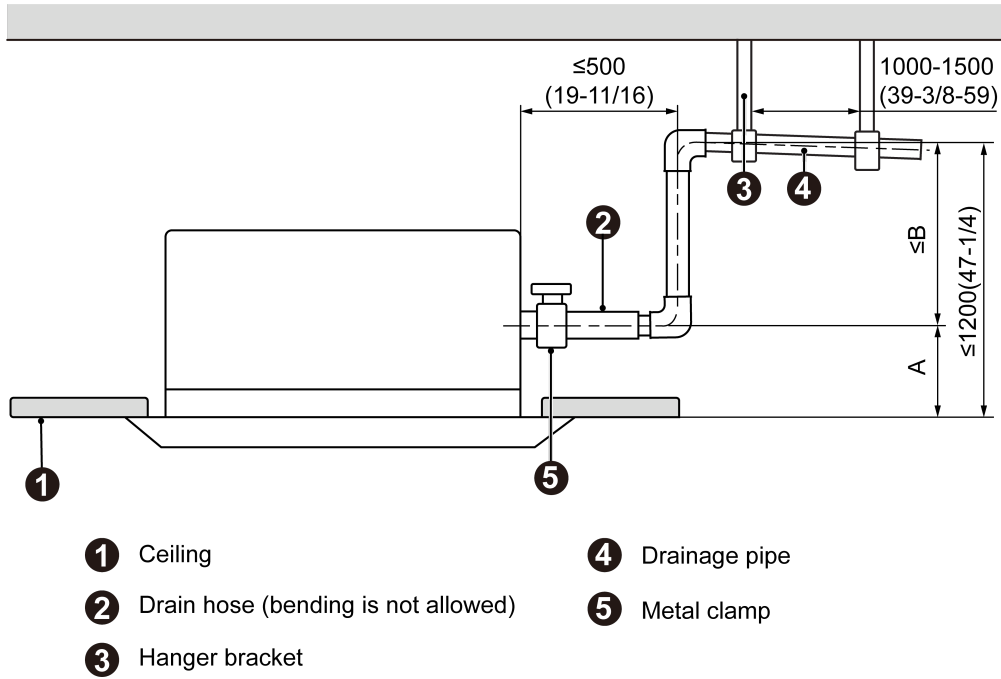

Fig.4.3.7

Unit: mm (inch)

Model	A	B	C
GMV-ND18T/NhE-T(U)	265 (10-7/16)	935 (36-13/16)	885 (34-7/8)
GMV-ND15T/NhE-T(U)			
GMV-ND12T/NhE-T(U)			
GMV-ND09T/NhE-T(U)			
GMV-ND07T/NhE-T(U)			
GMV-ND05T/NhE-T(U)			

(11) During the installation, distance from soft drain pipe to the gasket is C when the bolt is tightened. It is not allowed to apply PVC or other related glue in the joints of two ends of drain pipe.

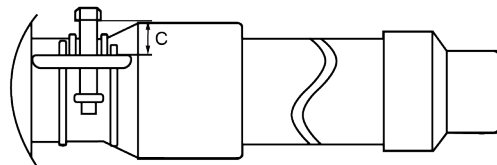

Fig.4.3.8

Unit: mm (inch)

Model	C
GMV-ND18T/NhE-T(U)	10±3(3/8±1/8)
GMV-ND15T/NhE-T(U)	
GMV-ND12T/NhE-T(U)	
GMV-ND09T/NhE-T(U)	
GMV-ND07T/NhE-T(U)	
GMV-ND05T/NhE-T(U)	

4.3.3 Test of Drainage System

(1) Please test drainage system after electric work is finished.

Inject approximately 1L purified water to drain pan from air vent, ensure that not to splash the water over the electrical components (e.g. water pump. etc.).

1) In case of commissioning finished, please energize the IDUs and switch to cooling or dry mode, meanwhile, the water pump operates, you can check the draining through the drain socket.

2) If communication wire is not connected, communication malfunction "C0" will occur after 60s of energizing. In this case, the water pump operates automatically. Check if the water pump drains normally through drainage port. The water pump will stop automatically after running for 10mins.

(2) During the test, please carefully check the drainage joint, make sure no any leakage occur.

(3) It's strongly recommend to do the drain test before ceiling decoration.

Unit: mm (inch)

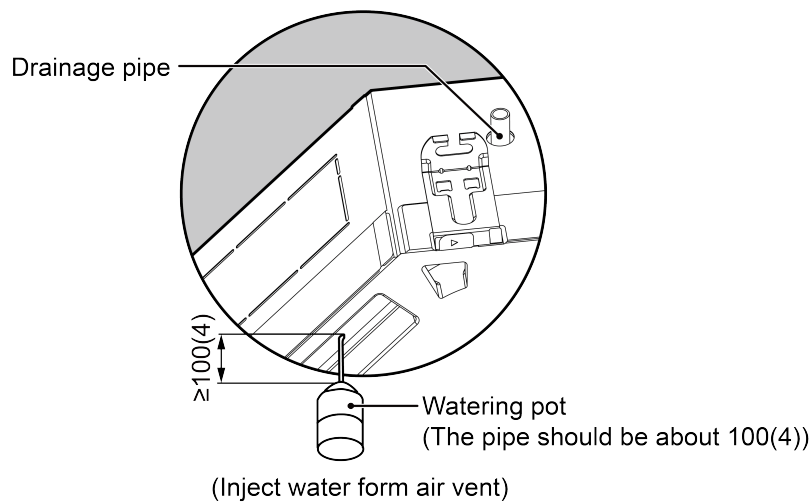

Fig.4.3.9

4.4 Locking Joint Installation

When the power cord and communication cable of the unit are connected, the power cable and communication cable need to be fixed through the side panel locking connector. The fixing process is as follows.

(1) Remove the locking joint bracket from the side panel.

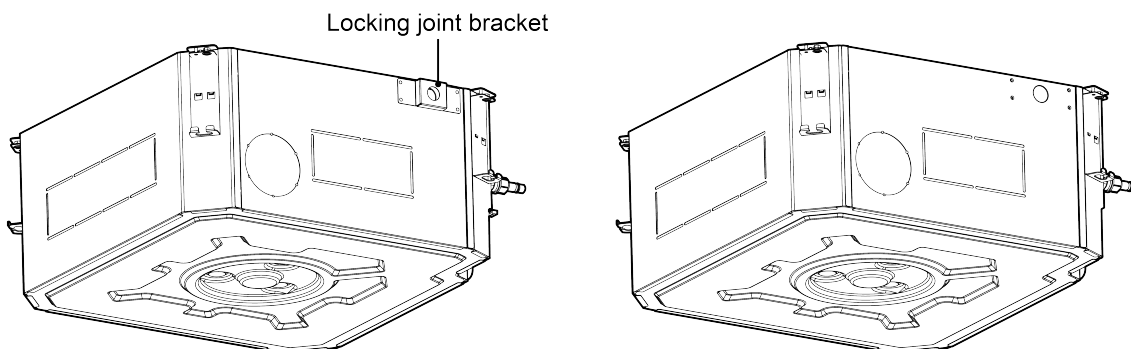

Fig.4.4.1

- (2) Attach the locking joint to the locking joint bracket.

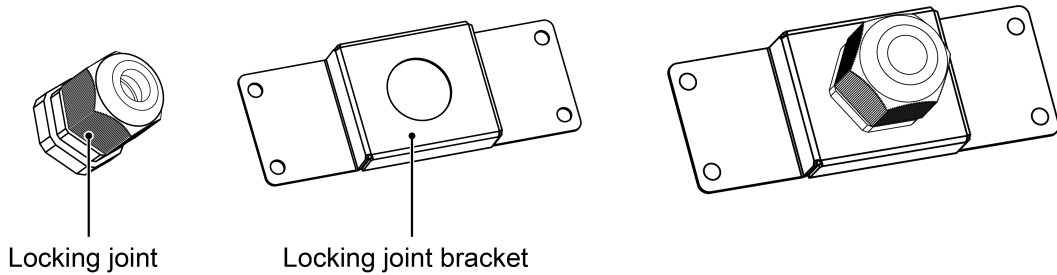

Fig.4.4.2

- (3) Power cable (communication line) passes through the locking joint and the side plate engineering line over the wire crossing hole.
- (4) Finally, reattach the locking joint bracket to the side panel.

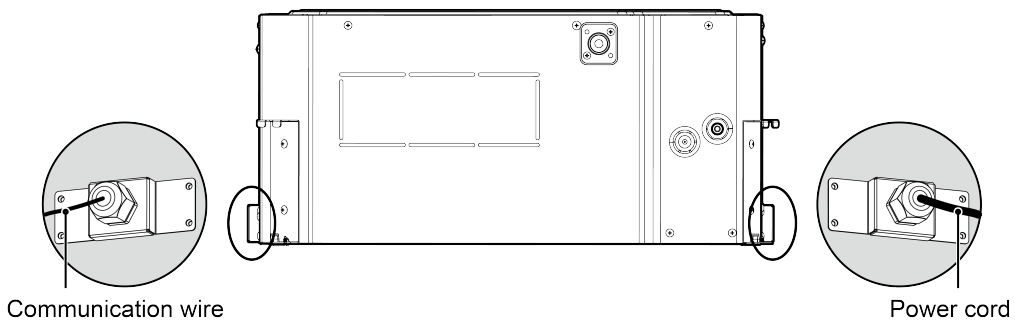

Fig.4.4.3

4.5 Panel Installation

4.5.1 Notices for Installation

- (1) Improper decorative panel installation could cause the following problems.

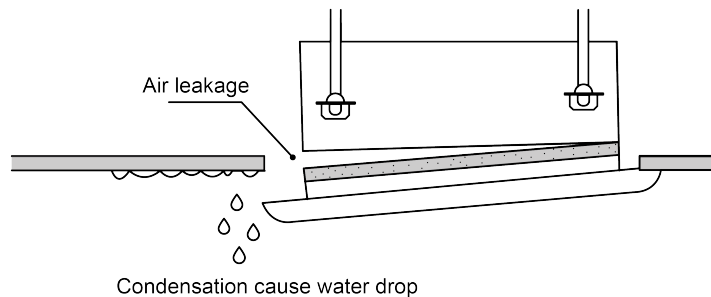

Fig.4.5.1

- (2) Ensure that it's clearance-free between decoration panel and ceiling board after installation, if not, please adjust the body position.

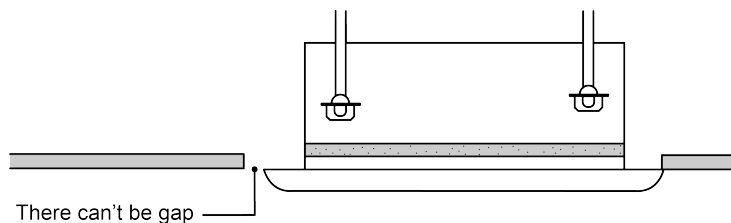

Fig.4.5.2

- (3) Connect the decoration panel terminals (Female) to body terminals (Male) as shown in Fig.4.5.3.

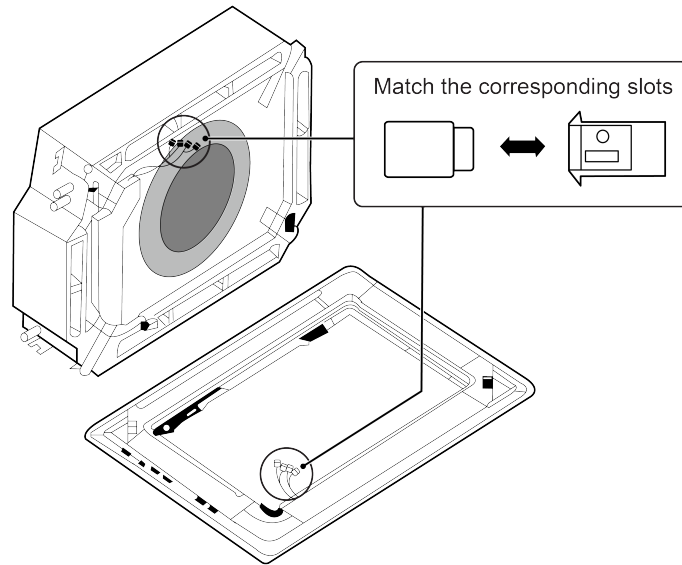

Fig.4.5.3

4.5.2 Panel Installation

- (1) Detach the panel's corner cap, there is a mark "piping side" on one of the 4 corners, adjust the panel direction so as to keep the mark and fittings on the same corner, as shown in Fig.4.5.4.

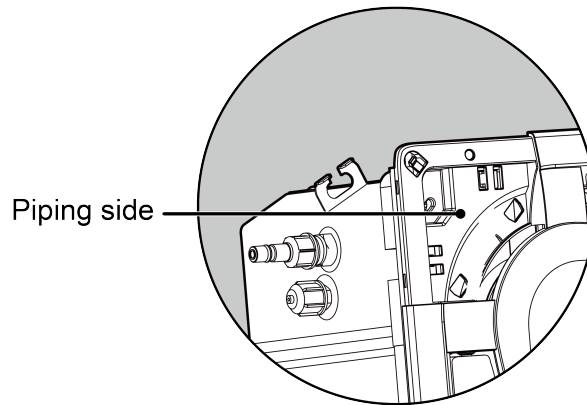

Fig.4.5.4

- (2) Adjust the position of panel to make the panel holes fix at the holes on the units.
- (3) Fix the 4 screws at the two side of panel, as shown in Fig.4.5.5.

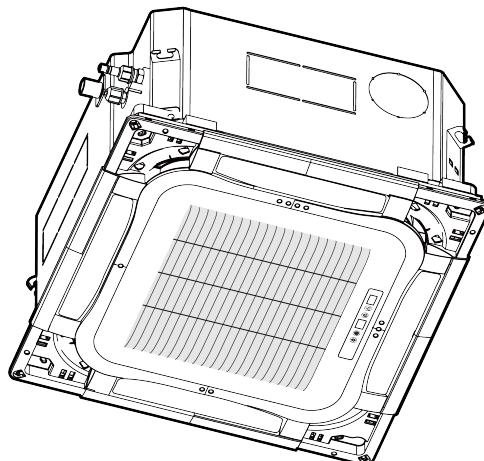

Fig.4.5.5

- (4) Detach the air inlet grille from panel, make a wiring connection of signal receiver. Notices that the connection wire not stuck in the middle of body and panel, or may cause air leakage and lead to condensation water drop.
- (5) Tighten 4 screws at each corner of panel respectively, fix the panel on the body firmly.
- (6) Tighten the screw until the thickness of sealing material between panel and indoor unit is about 5-8mm(3/16~5/16inch).

Unit: mm (inch)

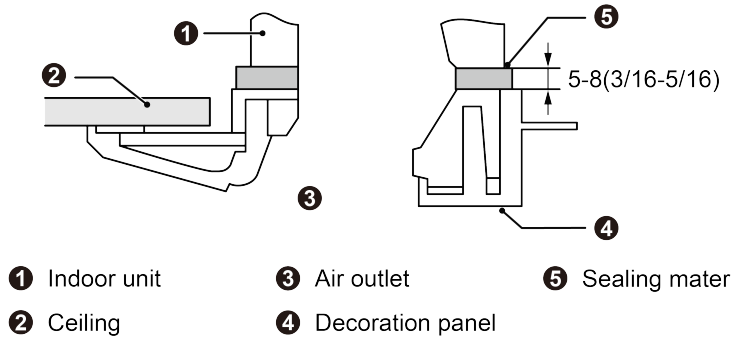

Fig.4.5.6

- (7) Tighten the “J”-shape hook in the accessories on the panel with screws, please refer to Fig.4.5.7.

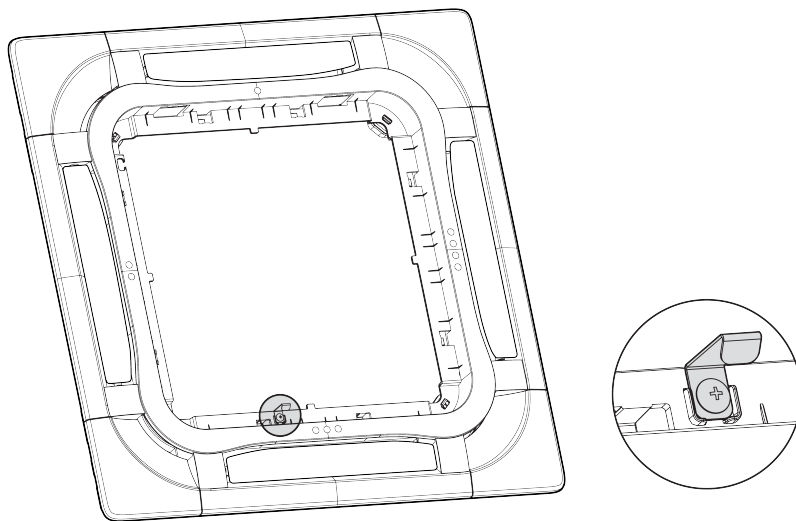

Fig.4.5.7

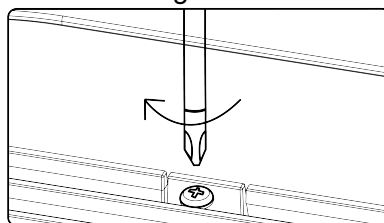

Fig.4.5.8

- (8) Tighten the “J” -shape metal sheet in the accessories on the grille with screws, please refer to Fig.4.5.9.

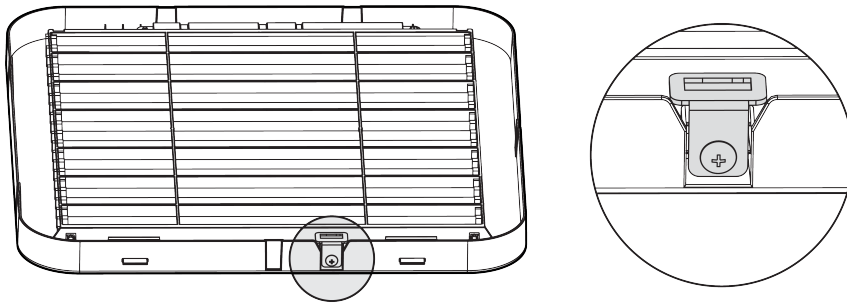

Fig.4.5.9

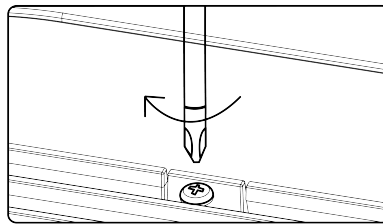

Fig.4.5.10

4.5.3 Grille Removal

Press out all the grille tabs, then the grille opens partially and exposes side screw. Remove the side screw to complete the grille removal.

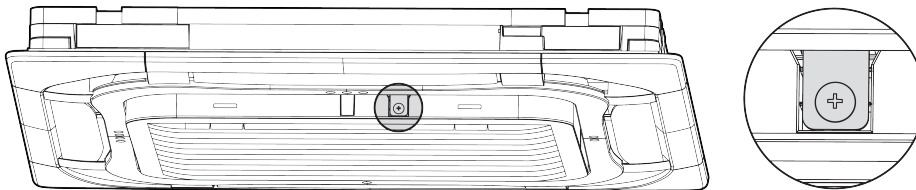

Fig.4.5.11

4.6 Installation of Wired Controller

Please refer to User Manual of Wired Controller for the installation details.

NOTICE When installation is finished, the unit must be tested and debugged before operation. Please refer to Instruction Manual of ODU for auto addressing and debugging details.

5 Wiring Work

⚠ WARNING

Before obtaining access to terminals, all supply circuits must be disconnected.

NOTICE

- (1) Units must be earthed securely, or it may cause electric shock.
- (2) Please carefully read the wiring diagram before carry out the wiring work, incorrect wiring could cause malfunction or even damage the unit.
- (3) The unit should be powered by independent circuit and specific socket.
- (4) The wiring should be in accordance with related regulations in order to ensure the units reliable running.
- (5) Install circuit breaker for branch circuit according to related regulations and electrical standards.
- (6) Keep cable away from refrigerant pipings, compressor and fan motor.
- (7) The communication wires should be separated from power cord and connection wire between indoor unit

NOTICE

(8) Adjust the static pressure via wired controller according to site circumstance.

(9) Field operation and installation specifications to meet NFPA 70.

5.1 Connection of Wire and Patch Board Terminal

(1) The connection of wire (as shown in Fig.5.1.1)

- 1) Strip about 25mm (1 inch) insulation of the wire end by stripping and cutting tool.
- 2) Remove the wiring screws on the terminal board.
- 3) Shape the tail of wire into ring by needle nose plier, and keep the gauge of ring in accordance with screw.
- 4) Use the screwdriver for tightening the terminal.

(2) The connection of stranded wire (as shown in Fig.5.1.2)

- 1) Strip about 10mm (3/8 inch) insulation of the end of stranded wire by stripping and cutting tool.
- 2) Loosen the wiring screws on terminal board.
- 3) Insert the wire into the ring tongue terminal and tighten by crimping tool.
- 4) Use the screwdriver for tightening the terminal.

Unit: mm (inch)

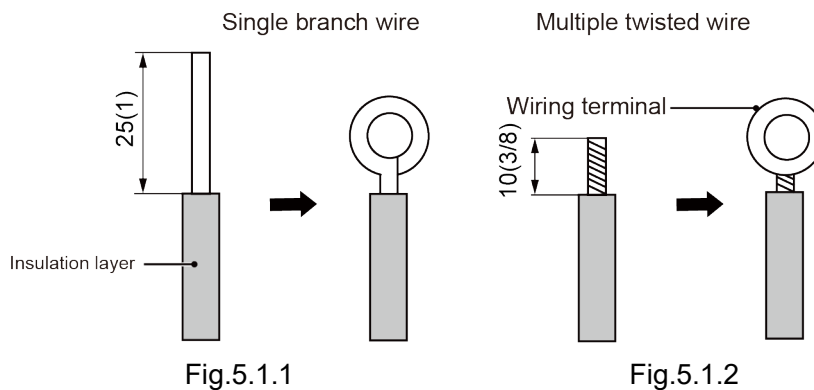
**5.2 Power Cord Connection**

NOTICE Every unit should be equipped with a circuit breaker for short-circuit and overload protection. In general, circuit breaker is at OFF status.

During operation, all indoor units and outdoor units belonging to the same system must be kept energized status. Otherwise, the unit can't operate normally.

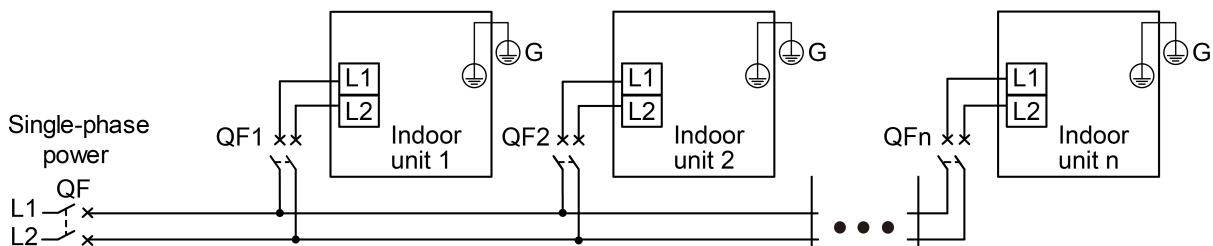

NOTICE The maximum connection quantity "n" for indoor unit is decided by the capacity of outdoor unit. Please refer to the unit capacity of unit for details.

Fig.5.2.1

- (1) Detach the electric box lid.
- (2) Let the power cord pass through the wiring through-holes.
- (3) Connect wires according to Fig. 5.2.1.
- (4) Fix the power cord with wiring clamp.
- (5) The wire diameter of power cord can't be less than 18AWG.

5.3 Connection of Communication Wire between Indoor Unit and Outdoor Unit (or Indoor Unit)

- (1) Detach the electric box lid.
- (2) Let the Communication cable pass through the wiring through-holes.
- (3) The weak current wires for the wired controller and other devices must also be run through conduits.
- (4) Connect the communication wire to terminal D1 and D2 of indoor 4-bit wiring board, as shown in Fig.5.3.1.

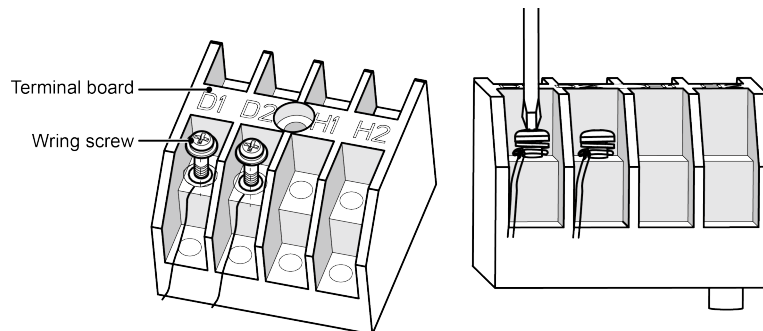
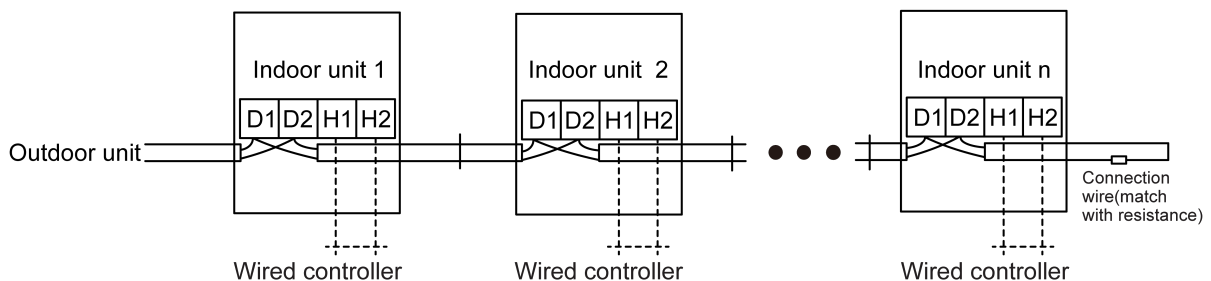

Fig.5.3.1



NOTICE Indoor unit quantity n is according to the outdoor unit capacity.

Fig.5.3.2

- (5) Fix the communication cable with clamp of electric box.
- (6) For more reliable communication, make sure connect the terminal resistor to the most downstream IDU of the communication bus (terminal D1 and D2), as shown in Fig. 5.3.2, terminal resistor is provided with each ODU.

5.4 Connect Communication Wire of Wired Controller

- (1) Open electric box cover of indoor unit.
- (2) Let the communication wire go through the rubber ring.
- (3) Connect the communication wire to terminal H1 and H2 of indoor 4-bit wiring board.
- (4) Fix the communication wire with wire clip on the electric box.
- (5) Wiring instructions of remote receiving light board and wired controller:

- 1) Wired controller is shown as Fig.5.4.1, wireless controller is shown as Fig.5.4.2, signal receiver is provided with panel as standard accessory.

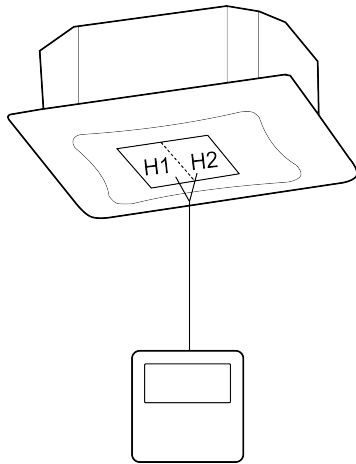

Fig.5.4.1

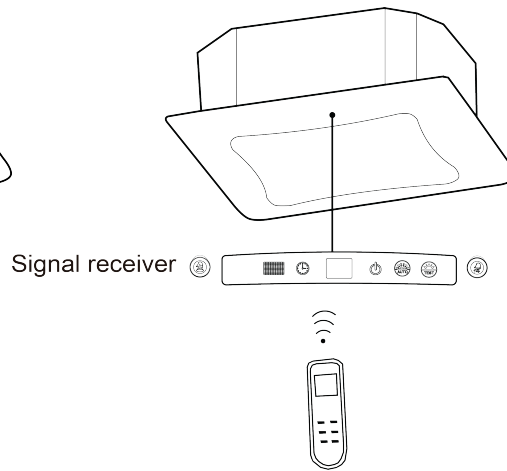

Fig.5.4.2

- 2) Both IDU and wired controller are equipped with signal receiver, and available for wireless control respectively.

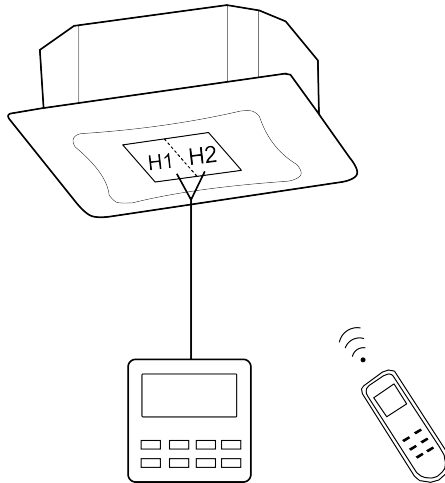

Fig.5.4.3

5.5 Illuminate for Connection of Wired Controller and Indoor Units Network

- (1) Communication wire of indoor unit and outdoor unit (or indoor unit) is connected to D1, D2.
- (2) Wired controller is connected to H1, H2.
- (3) One indoor unit can connect two wired controllers that must be set as master one and slave one.
- (4) One wired controller can control 16 indoor units in maximum at the same time (as shown in Fig.5.5.1).

NOTICE

- (1) The type of indoor units must be the same if they are controlled by the same wired controller.
- (2) When the indoor unit is controlled by two wired controllers, the addresses of the two wired controllers should be different through address setting. Address 1 is for main controller; Address 2 is for slave controller. Detailed setting please refer to the instruction manual of wired controller.

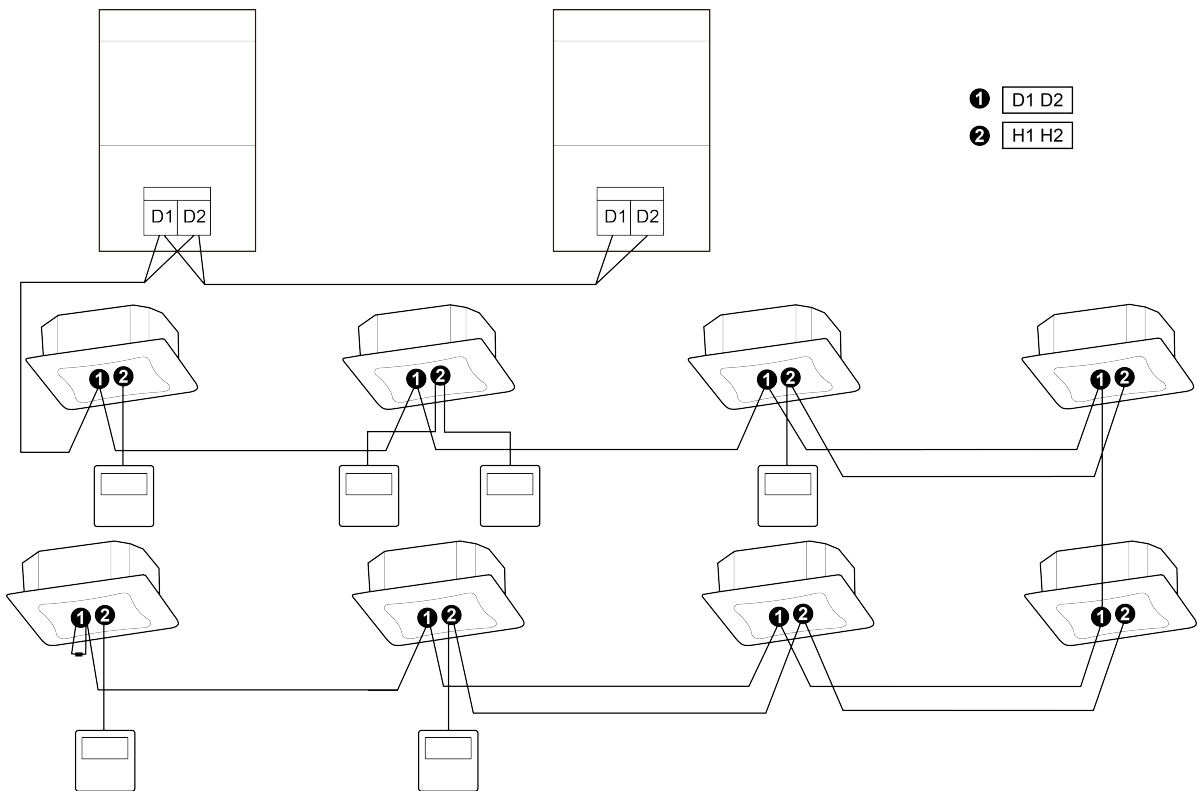

Fig.5.5.1

6 Routine Maintenance

NOTICE

- | |
|---|
| (1) Do not turn off the unit and cut off the main power supply when cleaning the air conditioner to avoid electric shock or injury. |
| (2) Stand at solid table when cleaning the unit. |
| (3) Do not clean the unit with hot water whose temperature is higher than 45°C(113°F) to prevent fade or deformation. |
| (4) Do not dry the filters by fire, or it may catch fire or become deformed. |
| (5) Clean the filter with a wet cloth dipped in neutral detergent. |
| (6) Please contact after-sales service staff if there is abnormal situation. |
| (7) Non-professional person is not allowed to open the air-in grille of indoor unit. |

6.1 About the Refrigerant Leakage Sensor

⚠ WARNING

- (1) The sensor has a lifetime of 15 years. At the end of lifetime or when the sensor fault, the indoor unit or wired controller displays error code “yd”, and emits an alarm sound. Measures will be taken automatically to prevent refrigerant leakage while the sensor fault.

The indoor fan will keep running to form ventilation airflow. The outdoor unit compressor will keep running for several minutes to recycle the refrigerant to the outdoor unit. Then the compressor will stop and the shut-off valves of outdoor unit will close so the refrigerant can not keep leaking.

The alarm can be canceled by operating the “On/Off” button of the wired controller or remote control. The indoor unit fan will keep running and the system can not operate until the sensor is replaced. Please contact our designated dealer or local service center to replace the sensor.

- (2) When the sensor detects refrigerant leak, the indoor unit or wired controller displays error code “yb”, and emits an alarm sound. Measures will be taken automatically to reduce the refrigerant concentration in the room.

The indoor fan will keep running to form ventilation airflow. The outdoor unit compressor will keep running for several minutes to recycle the refrigerant to the outdoor unit. Then the compressor will stop and the shut-off valves of outdoor unit will close so the refrigerant can not keep leaking.

The alarm can be canceled by operating the “On/Off” button of the wired controller or remote control. The indoor unit fan will keep running and the system can not operate until the leakage is repaired. Please contact our designated dealer or local service center.

- (3) Disassembly and installation steps of Refrigerant Sensor.

Disassembly:

Remove the 2 Refrigerant Sensor fixing screws, and then you can remove the Refrigerant Sensor.

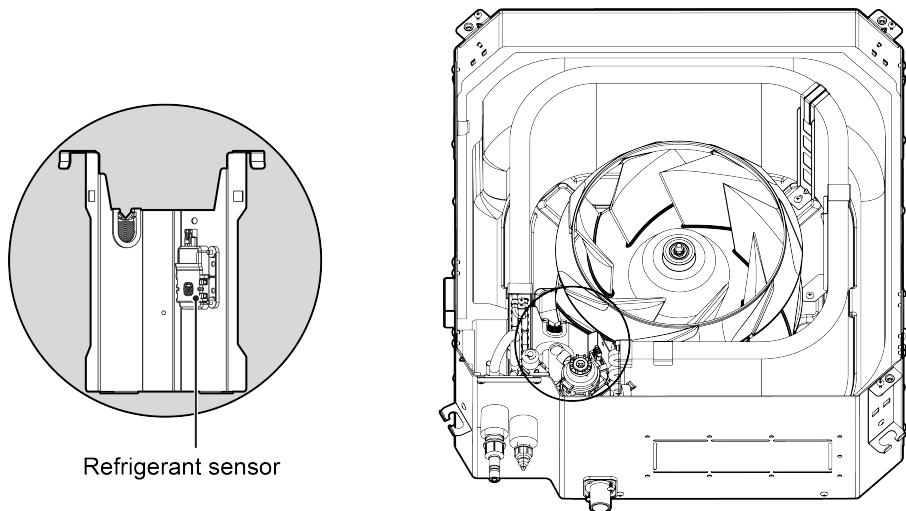

Fig.6.1.1

Installation:

Take a new Refrigerant Sensor, fix it on the Mounting Plate with 2 screws, and then insert the connector of the Refrigerant Sensor.

⚠ WARNING

- (1) The R32 refrigerant leakage sensor must be replaced after malfunction or at the end of its lifetime. ONLY authorized persons may replace the sensor. Only refrigerant leakage sensor of the specified manufacturer can be used.
- (2) The R32 refrigerant leakage sensor is a semiconductor detector which may incorrectly detect substances other than R32 refrigerant. Avoid using chemical substances (e.g. organic solvents, hair spray, paint) in high concentrations, in the close proximity of the indoor unit because this may cause misdetection of the R32 refrigerant leakage sensor.
- (3) High humidity environment will cause the R32 refrigerant leakage sensor fault, avoid installing indoor unit in high humidity environment or generating high temperature steam

near indoor unit.

6.2 Cleaning of Filter

- (1) Remove the filters from inlet of IDU. Use a vacuum cleaner to remove dust. If the filters are dirty, wash them with warm water and mild detergent, and dry the filters in the shade.
- (2) If the unit used in the environment with much dust, please clean it regularly (Usually once every two weeks).

6.3 Maintenance before the Seasonal Use

- (1) Check if the air inlet and air outlet of indoor and outdoor unit are blocked.
- (2) Check if securely grounded.
- (3) Check if all the power cord and communication cable are securely connected.
- (4) Check if any error code displayed after energized.

6.4 Maintenance after the Seasonal Use

- (1) Set the unit in fan mode for half a day in a sunny day to dry the inner part of unit.
- (2) When the unit won't be used for a long time, please cut off power supply for energy saving; the characters on the wired controller screen will disappear after cutting off the power supply.

7 Table of Error Codes for Indoor Unit

Error Code	Content	Error Code	Content	Error Code	Content
L0	Indoor Unit Error	LA	Indoor Units Incompatibility Error	d9	Jumper Cap Error
L1	Indoor Fan Protection	LH	Low Air Quality Warning	dA	Indoor Unit Network Address Error
L2	E-heater Protection	LC	ODU-IDU Incompatibility Error	dH	Wired Controller PCB Error
L3	Water Full Protection	d1	Indoor Unit PCB Error	dC	Capacity DIP Switch Setting Error.
L4	Wired Controller Power Supply Error	d3	Ambient Temperature Sensor Error	dL	Outlet Air Temperature Sensor Error
L5	Freeze protection	d4	Inlet Pipe Temperature Sensor Error	dE	Indoor Unit CO ₂ Sensor Error
L7	No Master Indoor Unit Error	d6	Outlet Pipe Temperature Sensor Error	C0	Communication Error
L8	Power Insufficiency Protection	d7	Humidity Sensor Error	AJ	Filter Cleaning Reminder
L9	Quantity Of Group Control Indoor Units Setting Error	d8	Water Temperature Error	o1	Low bus bar voltage of indoor unit
o2	High bus bar voltage of indoor unit	o3	IPM Module Protection of Indoor Unit	o4	Failure Startup of Indoor Unit
o5	Overcurrent Protection of Indoor Unit	o6	Current Detection Circuit Malfunction of Indoor Unit	o7	Desynchronizing Protection of Indoor Unit
o8	Communication Malfunction of Indoor Unit's Drive	o9	Communication Malfunction of Main Mater of Indoor Unit	oA	High temperature of Indoor Unit's Module
ob	Malfunction of Temperature Sensor of Indoor Unit's Module	oC	Charging Circuit Malfunction of Indoor Unit	o0	Other Drive Malfunction

Error Code	Content	Error Code	Content	Error Code	Content
db	Special Code: Field Debugging Code	yb	Refrigerant Leakage Protection	yd	Malfunction of Refrigerant Detection Sensor
En	Malfunction of System Refrigerant Detection	—	—	—	—

8 Troubleshooting

The air conditioner is not expected to be serviced by users. Incorrect repair may cause electric shock or fire, so please contact an authorized service center for professional service. The following checks prior to contact may save your time and money.

Phenomenon	Troubleshooting
The unit can't start.	<ul style="list-style-type: none"> ① Power supply is not connected. ② Circuit breaker tripping caused by leakage of electricity. ③ Input voltage is too low. ④ Defect of main PC-board.
The unit stops after running for a while.	<ul style="list-style-type: none"> ① The inlet or outlets of ODU or IDU are blocked by obstacle.
Poor cooling effect.	<ul style="list-style-type: none"> ① The filter is dirty. ② Too heavy heat load of room (e.g. too many people). ③ Door or windows is open. ④ Inlet and outlet of IDU are blocked. ⑤ Setting temperature is too high. ⑥ Refrigerant is insufficient (e.g. refrigerant leakage).
Poor heating effect.	<ul style="list-style-type: none"> ① The filter is dirty. ② Door or window is open. ③ Setting temperature is too low. ④ Refrigerant is insufficient (e.g. refrigerant leakage).
Indoor fan doesn't start up during heating.	<ul style="list-style-type: none"> ① At starting, the IDU fan could not operate till the heat exchange become hot, for preventing delivering the cool air. ② At defrosting, the IDU fan stopped due to system switch to cooling mode. For preventing delivering the cool air, and resume operating after defrosting.

NOTICE If air conditioner still fails to work normally after checking and handling as described above, please stop using it immediately and contact local service center for assistance.

9 Unventilated Areas

⚠ WARNING The non-FIXED APPLIANCE shall be stored in an area where the room size corresponds to the room area as specified for operation;

⚠ WARNING The non-FIXED APPLIANCE shall be stored in a room without continuously operating open flames (for example an operating gas appliance) or other POTENTIAL IGNITION SOURCES (for example an operating electric heater, hot surfaces);

⚠ WARNING If appliances with A2L REFRIGERANTS connected via an air duct system to one or more rooms are installed in a room with an area less than Amin, that room shall be without continuously operating open flames (for example an operating gas appliance) or other POTENTIAL IGNITION SOURCES (for example an operating electric heater, hot surfaces). A flame-producing device may be installed in the same space if the device is provided with an effective flame arrest;

⚠ WARNING "Auxiliary devices which may be a POTENTIAL IGNITION SOURCE shall

not be installed in the duct work. Examples of such POTENTIAL IGNITION SOURCES are hot surfaces with a temperature exceeding 648 °C and electric switching devices”;

⚠ WARNING That only auxiliary devices approved by the appliance manufacturer or declared suitable with the refrigerant shall be installed in connecting ductwork. The manufacturer can list in the instructions all approved auxiliary devices by the manufacturer and model number for use with the specific appliance, if those devices have a potential to become an ignition source.

10 Qualification of Worker

The manual shall contain specific information about the required qualification of the working personnel for maintenance, service and repair operations. Every working procedure that affects safety means shall only be carried out by competent persons. The training of these procedures is carried out by national training organizations or manufacturers that are accredited to teach the relevant national competency standards that may be set in legislation. The achieved competence should be documented by a certificate.

Examples for such working procedures are:

- (1) breaking into the refrigerating circuit;
- (2) opening of sealed components;
- (3) opening of ventilated enclosures.

11 Transportation, Marking and Storage for Units that Employ Flammable Refrigerants

11.1 General

The following information is provided for units that employ FLAMMABLE REFRIGERANTS.

11.2 Transport of Equipment Containing Flammable Refrigerants

Attention is drawn to the fact that additional transportation regulations may exist with respect to equipment containing flammable gas. The maximum number of pieces of equipment or the configuration of the equipment permitted to be transported together will be determined by the applicable transport regulations.

11.3 Marking of Equipment Using Signs

Signs for similar appliances used in a work area are generally addressed by local regulations and give the minimum requirements for the provision of safety and/ or health signs for a work location.

All required signs are to be maintained and employers should ensure that employees receive suitable and sufficient instruction and training on the meaning of appropriate safety signs and the actions that need to be taken in connection with these signs.

The effectiveness of signs should not be diminished by too many signs being placed together.

Any pictograms used should be as simple as possible and contain only essential details.

11.4 Disposal of Equipment Using Flammable Refrigerants

See national regulations.

11.5 Storage of Equipment/Appliances

The storage of the appliance should be in accordance with the applicable regulations or instructions, whichever is more stringent.

11.6 Storage of Packed (Unsold) Equipment

Storage package protection should be constructed in such a way that mechanical damage to the equipment inside the package will not cause a leak of the REFRIGERANT CHARGE.

The maximum number of pieces of equipment permitted to be stored together will be determined by local regulations.

12 Information on Servicing

12.1 General

The manual shall contain specific information for service personnel according to 12.2 to 12.10.

12.2 Checks to the Area

Prior to beginning work on systems containing FLAMMABLE REFRIGERANTS, safety checks are necessary to ensure that the risk of ignition is minimized. For repair to the REFRIGERATING SYSTEM, 12.3 to 12.7 shall be completed prior to conducting work on the system.

12.3 Work Procedure

Work shall be undertaken under a controlled procedure so as to minimize the risk of a flammable gas or vapor being present while the work is being performed.

12.4 General Work Area

All maintenance staff and others working in the local area shall be instructed on the nature of work being carried out. Work in confined spaces shall be avoided.

12.5 Checking for Presence of Refrigerant

The area shall be checked with an appropriate refrigerant detector prior to and during work, to ensure the technician is aware of potentially toxic or flammable atmospheres. Ensure that the leak detection equipment being used is suitable for use with all applicable refrigerants, i.e. non-sparking, adequately sealed or intrinsically safe.

12.6 Presence of Fire Extinguisher

If any hot work is to be conducted on the refrigerating equipment or any associated parts, appropriate fire extinguishing equipment shall be available to hand. Have a dry powder or CO₂ fire extinguisher adjacent to the charging area.

12.7 No Ignition Sources

No person carrying out work in relation to a REFRIGERATING SYSTEM which involves exposing any pipe work shall use any sources of ignition in such a manner that it may lead to the risk of fire or explosion. All possible ignition sources, including cigarette smoking, should be kept sufficiently far away from the site of installation, repairing, removing and disposal, during which refrigerant can

possibly be released to the surrounding space. Prior to work taking place, the area around the equipment is to be surveyed to make sure that there are no flammable hazards or ignition risks. “No Smoking” signs shall be displayed.

12.8 Ventilated Area

Ensure that the area is in the open or that it is adequately ventilated before breaking into the system or conducting any hot work. A degree of ventilation shall continue during the period that the work is carried out. The ventilation should safely disperse any released refrigerant and preferably expel it externally into the atmosphere.

12.9 Checks to the Refrigerating Equipment

Where electrical components are being changed, they shall be fit for the purpose and to the correct specification. At all times the manufacturer’s maintenance and service guidelines shall be followed. If in doubt, consult the manufacturer’s technical department for assistance. The following checks shall be applied to installations using FLAMMABLE REFRIGERANTS:

- (1) The actual REFRIGERANT CHARGE is in accordance with the room size within which the refrigerant containing parts are installed;
- (2) The ventilation machinery and outlets are operating adequately and are not obstructed;
- (3) If an indirect refrigerating circuit is being used, the secondary circuit shall be checked for the presence of refrigerant;
- (4) Marking to the equipment continues to be visible and legible. Markings and signs that are illegible shall be corrected;
- (5) Refrigerating pipe or components are installed in a position where they are unlikely to be exposed to any substance which may corrode refrigerant containing components, unless the components are constructed of materials which are inherently resistant to being corroded or are suitably protected against being so corroded.

12.10 Checks to Electrical Devices

Repair and maintenance to electrical components shall include initial safety checks and component inspection procedures. If a fault exists that could compromise safety, then no electrical supply shall be connected to the circuit until it is satisfactorily dealt with. If the fault cannot be corrected immediately but it is necessary to continue operation, an adequate temporary solution shall be used. This shall be reported to the owner of the equipment so all parties are advised. Initial safety checks shall include:

- (1) That capacitors are discharged: this shall be done in a safe manner to avoid possibility of sparking;
- (2) That no live electrical components and wiring are exposed while charging, recovering or purging the system;
- (3) That there is continuity of earth bonding.

WARNING

Only auxiliary devices approved by the appliance manufacturer or declared suitable with the

refrigerant shall be installed in connecting ductwork for duct connected appliances, false ceilings or drop ceilings may be used as a return air plenum if a REFRIGERANT DETECTION SYSTEM is provided in the appliance and any external connections are also provided with a sensor immediately below the return air plenum duct joint.

12.11 Pipe Installation

That pipe-work including piping material, pipe routing, and installation shall include protection from physical damage in operation and service, and be in compliance with national and local codes and standards, such as ASHRAE 15, ASHRAE 15.2, IAPMO Uniform Mechanical Code, ICC International Mechanical Code, or CSA B52. All field joints shall be accessible for inspection prior to being covered or enclosed.

That after completion of field piping for split systems, the field pipework shall be pressure tested with an inert gas and then vacuum tested prior to refrigerant charging, according to the following requirements field-made refrigerant joints indoors shall be tightness tested. The test method shall have a sensitivity of 5 grams per year of refrigerant or better under a pressure of at least 0,25 times the maximum allowable pressure. No leak shall be detected.

The minimum test pressure for the low side of the system shall be the low side design pressure and the minimum test pressure for the high side of the system shall be the high side design pressure, unless the high side of the system, cannot be isolated from the low side of the system in which case the entire system shall be pressure tested to the low side design pressure.

13 Sealed Electrical Components shall be Replaced

14 Intrinsically Safe Components must be Replaced

15 Cabling

Check that cabling will not be subject to wear, corrosion, excessive pressure, vibration, sharp edges or any other adverse environmental effects. The check shall also take into account the effects of aging or continual vibration from sources such as compressors or fans.

16 Detection of Flammable Refrigerants

Under no circumstances shall potential sources of ignition be used in the searching for or detection of refrigerant leaks. A halide torch (or any other detector using a naked flame) shall not be used.

The following leak detection methods are deemed acceptable for all refrigerant systems.

Electronic leak detectors may be used to detect refrigerant leaks but, in the case of FLAMMABLE REFRIGERANTS, the sensitivity may not be adequate, or may need re-calibration. (Detection equipment shall be calibrated in a refrigerant-free area.) Ensure that the detector is not a potential source of ignition and is suitable for the refrigerant used. Leak detection equipment shall be set at a percentage of the LFL of the refrigerant and shall be calibrated to the refrigerant employed, and the appropriate percentage of gas (25 % maximum) is confirmed.

Leak detection fluids are also suitable for use with most refrigerants but the use of detergents containing chlorine shall be avoided as the chlorine may react with the refrigerant and corrode the

copper pipe-work.

NOTICE Examples of leak detection fluids are:

- (1) Bubble method.
- (2) Fluorescent method agents.

If a leak is suspected, all naked flames shall be removed/extinguished.

If a leakage of refrigerant is found which requires brazing, all of the refrigerant shall be recovered from the system, or isolated (by means of shut off valves) in a part of the system remote from the leak. Removal of refrigerant shall be according to Clause 17.

17 Removal and Evacuation

When breaking into the refrigerant circuit to make repairs-or for any other purpose -conventional procedures shall be used. However, for flammable refrigerants it is important that best practice be followed, since flammability is a consideration. The following procedure shall be adhered to: The refrigerant charge shall be recovered into the correct recovery cylinders if venting is not allowed by local and national codes. For appliances containing flammable refrigerants, the system shall be purged with oxygen-free nitrogen to render the appliance safe for flammable refrigerants. This process might need to be repeated several times.

- safely remove refrigerant following local and national regulations;
 - evacuate;
 - purge the circuit with inert gas (optional for A2L);
 - evacuate (optional for A2L);
 - continuously flush or purge with inert gas when using flame to open circuit;
- and
- open the circuit.

Compressed air or oxygen shall not be used for purging refrigerant systems.

For appliances containing flammable refrigerants, refrigerants purging shall be achieved by breaking the vacuum in the system with oxygen-free nitrogen and continuing to fill until the working pressure is achieved, then venting to atmosphere, and finally pulling down to a vacuum (optional for A2L). This process shall be repeated until no refrigerant is within the system (optional for A2L). When the final oxygen-free nitrogen charge is used, the system shall be vented down to atmospheric pressure to enable work to take place.

The outlet for the vacuum pump shall not be close to any potential ignition sources, and ventilation shall be available.

18 Charging Procedures

In addition to conventional charging procedures, the following requirements shall be followed.

- (1) Ensure that contamination of different refrigerants does not occur when using charging equipment.
- (2) Hoses or lines shall be as short as possible to minimize the amount of refrigerant contained in them.
- (3) Cylinders shall be kept in an appropriate position according to the instructions.

- (4) Ensure that the REFRIGERATING SYSTEM is earthed prior to charging the system with refrigerant.
- (5) Label the system when charging is complete (if not already).
- (6) Extreme care shall be taken not to overfill the REFRIGERATING SYSTEM.

Prior to recharging the system, it shall be pressure-tested with the appropriate purging gas. The system shall be leak-tested on completion of charging but prior to commissioning. A follow up leak test shall be carried out prior to leaving the site.

19 Decommissioning

Before carrying out this procedure, it is essential that the technician is completely familiar with the equipment and all its detail. It is recommended good practice that all refrigerants are recovered safely.

Prior to the task being carried out, an oil and refrigerant sample shall be taken in case analysis is required prior to re-use of recovered refrigerant. It is essential that electrical power is available before the task is commenced.

- (1) Become familiar with the equipment and its operation) Isolate system electrically.
- (2) Before attempting the procedure, ensure that:
 - 1) Mechanical handling equipment is available, if required, for handling refrigerant cylinders;
 - 2) All personal protective equipment is available and being used correctly;
 - 3) The recovery process is supervised at all times by a competent person;
 - 4) Recovery equipment and cylinders conform to the appropriate standards.
- (3) Pump down refrigerant system, if possible.
- (4) If a vacuum is not possible, make a manifold so that refrigerant can be removed from various parts of the system.
- (5) Make sure that cylinder is situated on the scales before recovery takes place.
- (6) Start the recovery machine and operate in accordance with instructions.
- (7) Do not overfill cylinders (no more than 80 % volume liquid charge).
- (8) Do not exceed the maximum working pressure of the cylinder, even temporarily.
- (9) When the cylinders have been filled correctly and the process completed, make sure that the cylinders and the equipment are removed from site promptly and all isolation valves on the equipment are closed off.
- (10) Recovered refrigerant shall not be charged into another REFRIGERATING SYSTEM unless it has been cleaned and checked.

20 Labeling

Equipment shall be labeled stating that it has been decommissioned and emptied of refrigerant. The label shall be dated and signed. For appliances containing FLAMMABLE REFRIGERANTS, ensure that there are labels on the equipment stating the equipment contains FLAMMABLE REFRIGERANT.

21 Recovery

When removing refrigerant from a system, either for servicing or decommissioning, it is recommended good practice that all refrigerants are removed safely.

When transferring refrigerant into cylinders, ensure that only appropriate refrigerant recovery cylinders are employed. Ensure that the correct number of cylinders for holding the total system charge is available. All cylinders to be used are designated for the recovered refrigerant and labeled for that refrigerant (i.e. special cylinders for the recovery of refrigerant). Cylinders shall be complete with pressure-relief valve and associated shut-off valves in good working order. Empty recovery cylinders are evacuated and, if possible, cooled before recovery occurs.

The recovery equipment shall be in good working order with a set of instructions concerning the equipment that is at hand and shall be suitable for the recovery of the flammable refrigerant. If in doubt, the manufacturer should be consulted. In addition, a set of calibrated weighing scales shall be available and in good working order. Hoses shall be complete with leak-free disconnect couplings and in good condition.

The recovered refrigerant shall be processed according to local legislation in the correct recovery cylinder, and the relevant waste transfer note arranged. Do not mix refrigerants in recovery units and especially not in cylinders. If compressors or compressor oils are to be removed, ensure that they have been evacuated to an acceptable level to make certain that flammable refrigerant does not remain within the lubricant. The compressor body shall not be heated by an open flame or other ignition sources to accelerate this process. When oil is drained from a system, it shall be carried out safely.

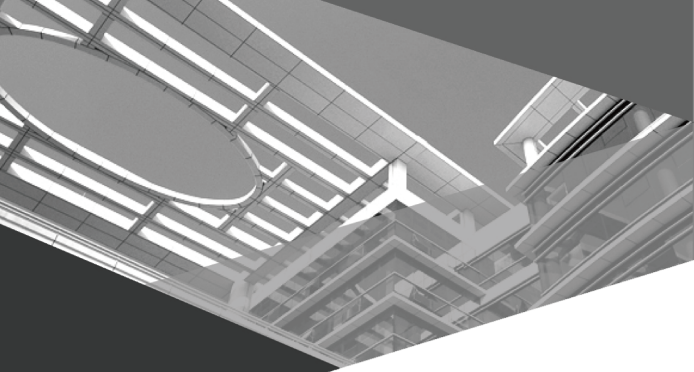

GREE ELECTRIC APPLIANCES, INC. OF ZHUHAI

Add: West Jinji Rd, Qianshan, Zhuhai,Guangdong, China, 519070

Tel: (+86-756) 8522218

Fax: (+86-756) 8669426

E-mail: global@cn.gree.com www.gree.com



600005069018