



Owner's Manual

Original Instructions

Multi Variable Air Conditioners
Wall Mounted Type Indoor Unit

Models:

GMV-ND06G/NhA1C-T(U)
GMV-ND07G/NhA1C-T(U)
GMV-ND09G/NhA1C-T(U)
GMV-ND12G/NhA1C-T(U)
GMV-ND14G/NhA1C-T(U)
GMV-ND18G/NhA1C-T(U)
GMV-ND24G/NhA1C-T(U)

GMV-ND06G/NhA3C-T(U)
GMV-ND07G/NhA3C-T(U)
GMV-ND09G/NhA3C-T(U)
GMV-ND12G/NhA3C-T(U)
GMV-ND14G/NhA3C-T(U)
GMV-ND18G/NhA3C-T(U)
GMV-ND24G/NhA3C-T(U)

Thank you for choosing this product. Please read this Owner's Manual carefully before operation and retain it for future reference.

If you have lost the Owner's Manual, please contact the local agent or visit www.gree.com or send an email to global@cn.gree.com for the electronic version.

GREE ELECTRIC APPLIANCES, INC. OF ZHUHAI

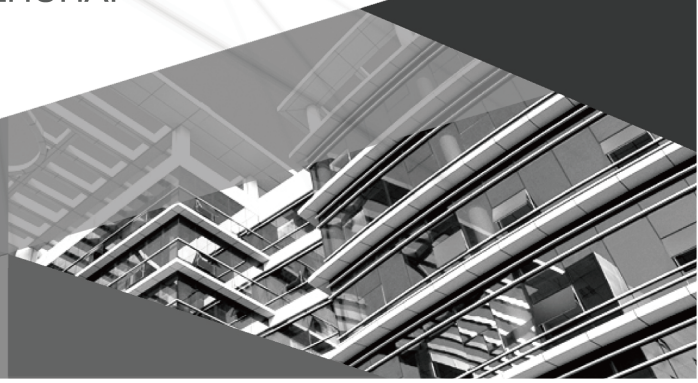

To Users

Thank you for selecting Gree product. Please read this instruction manual carefully before installing and using the product, so as to master and correctly use the product. In order to guide you to correctly install and use our product and achieve expected operating effect, we hereby instruct as below:

- (1) This appliance is not intended for use by persons (including children) with reduced physical, sensory or mental capabilities, or lack of experience and knowledge, unless they have been given supervision or instruction concerning use of the appliance by a person responsible for their safety. Children should be supervised to ensure that they do not play with the appliance.
- (2) In order to ensure reliability of product, the product may consume some power under stand-by status for maintaining normal communication of system and preheating refrigerant and lubricant. If the product is not to be used for long, cut off the power supply; please energize and preheat the unit in advance before reusing it.
- (3) Please properly select the model according to actual using environment, otherwise it may impact the using convenience.
- (4) This product can't be installed at corrosive, inflammable or explosive environment or the place with special requirements, such as kitchen. Otherwise, it will affect the normal operation or shorten the service life of the unit, or even cause fire hazard or serious injury. As for above special places, please adopt special air conditioner with anti-corrosive or anti-explosion function.
- (5) If the product needs to be installed, moved or maintained, please contact our designated dealer or local service center for professional support. Users should not disassemble or maintain the unit by themselves, otherwise it may cause relative damage, and our company will bear no responsibilities.
- (6) All the illustrations and information in the instruction manual are only for reference. In order to make the product better, we will continuously conduct improvement and innovation. If there is adjustment in the product, please subject to actual product.







Exception Clauses

Manufacturer will bear no responsibilities when personal injury or property loss is caused by the following reasons:

- (1) Damage the product due to improper use or misuse of the product.
- (2) Alter, change, maintain or use the product with other equipment without abiding by the instruction manual of manufacturer.
- (3) After verification, the defect of product is directly caused by corrosive gas.
- (4) After verification, defects are due to improper operation during transportation of product.
- (5) Operate, repair, maintain the unit without abiding by instruction manual or related regulations.
- (6) After verification, the problem or dispute is caused by the quality specification or performance of parts and components that produced by other manufacturers.
- (7) The damage is caused by natural calamities, bad using environment or force majeure.

Preface

For correct installation and operation, please read all instructions carefully. Understand these signal words: **DANGER**, **WARNING**, **CAUTION** and **NOTICE**. These words are used with the safety-alert symbol.

 DANGER	This is the safety alert symbol. It is used to alert you to potential personal injury hazards. Obey all safety messages that follow this symbol to avoid possible injury or death.
 WARNING	This mark indicates procedures which, if improperly performed, might lead to the death or serious injury of the user.
 CAUTION	This mark indicates procedures which, if improperly performed, might possibly result in personal harm to the user, or damage to property.
NOTICE	NOTICE is used to address practices not related to personal injury.
 Refrigerant Safety Group A2L R32	Appliance filled with flammable gas R32.
	Before install the appliance, read the installation manual first.
	Before use the appliance, read the owner's manual first.
	Before repair the appliance, read the service manual first.

 WARNING	
(1)	Do not use means to accelerate the defrosting process or to clean, other than those recommended by the manufacturer.
(2)	The appliance shall be stored in a room without continuously operating ignition sources (for example: open flames, an operating gas appliance or an operating electric heater).
(3)	Do not pierce or burn.
(4)	Be aware that refrigerants might not contain an odour.

This appliance is not intended for use by persons (including children) with reduced physical, sensory or mental capabilities, or lack of experience and knowledge, unless they have been given supervision or instruction concerning use of the appliance by a person responsible for their safety.

Children should be supervised to ensure that they do not play with the appliance.



DISPOSAL: Do not dispose this product as unsorted municipal waste. Collection of such waste separately for special treatment is necessary.



Contents

1 Safety Notices (Please be Sure to Abide Them)	1
2 Product Introduction	2
2.1 Outline of the Unit and Main Parts.....	2
2.2 Rated Operating Condition	2
2.3 The Range of Production Working Temperature	2
2.4 Minimum Room Area	3
2.5 Calculation Method of Releasable Charge (m_{REL})	4
3 Installation Instruction	6
3.1 Location for Installation.....	6
3.2 Schematic Diagram of Installation Spaces	6
3.3 Requirements for Communication Line	6
3.4 Electric Installation.....	8
4 Installation Instructions	8
4.1 Installation of Indoor Unit.....	8
4.2 The Installation of the Rear Panel	9
4.3 Preparation of the Piping Hole.....	9
4.4 Installation of the Drainage Pipe.....	9
4.5 Installation the Connection Pipes	10
5 Wiring Work	11
5.1 Connect Cables and Terminals of Wiring Board.....	11
5.2 Power Cord Connection	12
5.3 Connection of Communication Line of IDU and ODU	12
5.4 Illuminate for Connection of Wired Controller and Indoor Units Network	13
5.5 Installation of the Indoor Unit.....	13
6 The Best Usage Method	14
7 Maintenance Method	15
7.1 About the Refrigerant Leakage Sensor	15
7.2 Cleaning Panel	15
7.3 Cleaning the Air Filters	16
7.4 Check before the Usage Season.....	16
7.5 Check after the Usage Season.....	16
8 Table of Error Codes for Indoor Unit	17
9 Malfunction Analyzing	17
9.1 Service Center.....	18
9.2 After-sales Service.....	18
10 Adjusting Method of the Air Direction	18
10.1 Adjusting Air Direction Up and Down.....	18

10.2 Adjusting Air Direction Left and Right	18
11 Unventilated Areas.....	18
12 Qualification of Worker	19
13 Transportation, Marking and Storage for Units that Employ Flammable Refrigerants.....	19
13.1 General.....	19
13.2 Transport of Equipment Containing Flammable Refrigerants.....	19
13.3 Marking of Equipment Using Signs	19
13.4 Disposal of Equipment Using Flammable Refrigerants	19
13.5 Storage of Equipment/Appliances	20
13.6 Storage of Packed (Unsold) Equipment	20
14 Information on Servicing.....	20
14.1 General.....	20
14.2 Checks to the Area	20
14.3 Work Procedure.....	20
14.4 General Work Area	20
14.5 Checking for Presence of Refrigerant	20
14.6 Presence of Fire Extinguisher	20
14.7 No Ignition Sources	20
14.8 Ventilated Area	21
14.9 Checks to the Refrigerating Equipment.....	21
14.10 Checks to Electrical Devices	21
14.11 Pipe Installation	22
15 Sealed Electrical Components Shall be Replaced	22
16 Intrinsically Safe Components Must be Replaced	22
17 Cabling.....	22
18 Detection of Flammable Refrigerants	22
19 Removal and Evacuation	23
20 Charging Procedures	23
21 Decommissioning.....	24
22 Labeling	24
23 Recovery.....	25

1 Safety Notices (Please be Sure to Abide Them)

⚠ WARNING
(1) This product can't be installed at corrosive, inflammable or explosive environment or the place with special requirements, such as kitchen. Otherwise, it will affect the normal operation or shorten the service life of the unit, or even cause fire hazard or serious injury. As for above special places, please adopt special air conditioner with anti-corrosive or anti-explosion function.
(2) Follow this instruction to complete the installation work. Please carefully read this manual before unit startup and service.
(3) Wire size of power cord should be large enough. The damaged power cord and connection wire should be replaced by exclusive cable.
(4) After connecting the power cord, please fix the electric box cover properly in order to avoid accident.
(5) Never fail to comply with the nitrogen charge requirements. Charge nitrogen when welding pipes.
(6) Never short-circuit or cancel the pressure switch to prevent unit damage.
(7) Please firstly connect the wired controller before energization, otherwise wired controller cannot be used.
(8) Before using the unit, please check if the piping and wiring are correct to avoid water leakage, refrigerant leakage, electric shock, or fire etc.
(9) Do not insert fingers or objects into air outlet/inlet grille.
(10) Open the door and window and keep good ventilation in the room to avoid oxygen deficit when the gas/oil supplied heating equipment is used.
(11) Never start up or shut off the air conditioner by means of directly plug or unplug the power cord.
(12) Turn off the unit after it runs at least five minutes; otherwise it will influence oil return of the compressor.
(13) Do not allow children operate this unit.
(14) Do not operate this unit with wet hands.
(15) Turn off the unit or cut off the power supply before cleaning the unit, otherwise electric shock or injury may happen.
(16) Never spray or flush water towards unit, otherwise malfunction or electric shock may happen.
(17) Do not expose the unit to the moist or corrosive circumstances.
(18) Under cooling mode, please don't set the room temperature too low and keep the temperature difference between indoor and outdoor unit within 5°C(41°F).
(19) User is not allowed to repair the unit. Fault service may cause electric shock or fire accidents. Please contact our designated dealer or local service center for help.
(20) Before installation, please check if the power supply is in accordance with the requirements specified on the nameplate. And also take care of the power safety.
(21) Installation should be conducted by dealer or qualified personnel. Please do not attempt to install the unit by yourself. Improper handling may result in water leakage, electric shock or fire disaster etc..
(22) Be sure to use the exclusive accessory and part to prevent the water leakage, electric shock and fire accidents.
(23) Electrify the unit 8 hours before operation. Please switch on for 8 hours before operation. Do not cut off the power when 24 hours short-time halting (to protect the compressor).
(24) If refrigerant leakage happens during installation, please ventilate immediately. Poisonous gas will emerge if the refrigerant gas meets fire.
(25) Volatile liquid, such as diluent or gas will damage the unit appearance. Only use soft cloth with a little neutral detergent to clean the outer casing of unit.
(26) If anything abnormal happens (such as burning smell), please power off the unit and cut off the main power supply, and then immediately contact our designated dealer or local service center. If abnormality keeps going, the unit might be damaged and lead to electric shock or fire.
(27) For appliances using FLAMMABLE REFRIGERANTS with safety features that depend upon the proper function of a leak detection system used for leak mitigation, the instructions and unit markings shall contain the substance of the following: "LEAK DETECTION SYSTEM installed. Unit must be powered except for service." If any remote located REFRIGERANT SENSOR is employed to detect leaked refrigerant, such a remote located REFRIGERANT SENSOR shall also apply to this marking or be accompanied by such instructions.
(28) Wall Mounted connected to an appliance shall not contain a potential ignition source.
(29) Keep any required ventilation openings clear of obstruction.
(30) Precautions shall be taken to avoid excessive vibration or pulsation to refrigerating piping.

⚠ WARNING

- (31) Protection devices, piping and fittings shall be protected as far as possible against adverse environmental effects, for example, the danger of water collecting and freezing in relief pipes or the accumulation of dirt and debris.
- (32) Provision shall be made for expansion and contraction of long runs of piping.
- (33) Piping in refrigerating systems shall be so designed and installed to minimize the likelihood hydraulic shock damaging the system.
- (34) Steel pipes and components shall be protected against corrosion with a rustproof coating before applying any insulation.

2 Product Introduction

2.1 Outline of the Unit and Main Parts

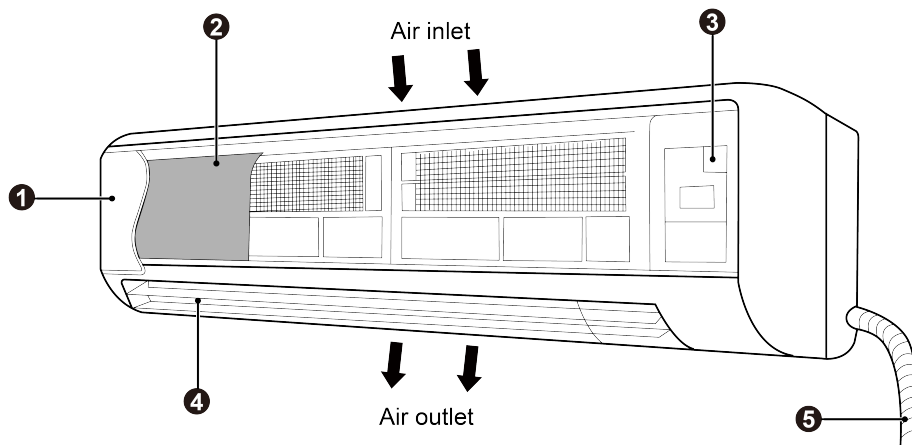

Fig. 2.1

NOTE

The appearances will be different by the different models of air conditioners.

No.	Part Name	No.	Part Name
①	Surface panel	④	Guide louver
②	Filter	⑤	Drain pipe
③	Wiring cover	—	—

2.2 Rated Operating Condition

Item	Indoor Side Condition		Outdoor Side Condition	
	Dry Bulb Temp°C (°F)	Wet Bulb Temp°C (°F)	Dry Bulb Temp°C (°F)	Wet Bulb Temp°C (°F)
Rated Cooling	26.7(80.0)	19.4(67.0)	35(95.0)	23.9(75.0)
Rated Heating	21.1(70.0)	15.6(60.0)	8.3(47.0)	6.1(43.0)

Indoor Unit Working Temperature Range: 16°C(60.8°F) ~32°C(89.6°F).

2.3 The Range of Production Working Temperature

—	Cooling	Heating
Indoor temperature	14°C (57.2°F)~25°C (77°F)WB	15°C (59°F)~27°C (80.6°F)DB
Indoor humidity	≤80%	

2.4 Minimum Room Area

Area of the room where the indoor unit is installed must meet the minimum room area in the following table:

Releasable Charge (kg)	Minimum Room Area(m ² /ft ²)					
	H ₀ ≥2.2m					
	H=2.2m(7.2ft)	H=2.5m(8.2ft)	H=3m(9.8ft)	H=3.5m(11.5ft)	H=4m(13ft)	H=5m(16.4ft)
2	6.0 / 64.0	5.3 / 56.3	4.4 / 47	3.8 / 40.3	3.3 / 35.2	2.7 / 28.2
2.2	6.6 / 70.4	5.8 / 62.0	4.8 / 51.6	4.2 / 44.3	3.6 / 38.7	2.9 / 31
2.4	7.2 / 76.8	6.3 / 67.6	5.3 / 56.3	4.5 / 48.3	4 / 42.3	3.2 / 33.8
2.6	7.8 / 83.2	6.8 / 73.2	5.7 / 61	4.9 / 52.3	4.3 / 45.8	3.4 / 36.6
2.8	8.4 / 89.6	7.4 / 78.8	6.2 / 65.7	5.3 / 56.3	4.6 / 49.3	3.7 / 39.4
3	9.0 / 96.0	7.9 / 84.5	6.6 / 70.4	5.7 / 60.4	5 / 52.8	4 / 42.3
3.2	9.6 / 102.4	8.4 / 90.1	7 / 75.1	6 / 64.4	5.3 / 56.3	4.2 / 45.1
3.4	10.2 / 108.8	8.9 / 95.7	7.5 / 79.8	6.4 / 68.4	5.6 / 59.8	4.5 / 47.9
3.6	10.7 / 115.2	9.5 / 101.4	7.9 / 84.5	6.8 / 72.4	5.9 / 63.4	4.8 / 50.7
3.8	11.3 / 121.6	10.0 / 107.0	8.3 / 89.2	7.1 / 76.4	6.3 / 66.9	5 / 53.5
4	11.9 / 128.0	10.5 / 112.6	8.8 / 93.9	7.5 / 80.5	6.6 / 70.4	5.3 / 56.3
4.2	12.5 / 134.4	11.0 / 118.2	9.2 / 98.5	7.9 / 84.5	6.9 / 73.9	5.5 / 59.1
4.4	13.1 / 140.8	11.6 / 123.9	9.6 / 103.2	8.3 / 88.5	7.2 / 77.4	5.8 / 62
4.6	13.7 / 147.2	12.1 / 129.5	10.1 / 107.9	8.6 / 92.5	7.6 / 81	6.1 / 64.8
4.8	14.3 / 153.5	12.6 / 135.1	10.5 / 112.6	9 / 96.5	7.9 / 84.5	6.3 / 67.6
5	14.9 / 159.9	13.1 / 140.8	10.9 / 117.3	9.4 / 100.6	8.2 / 88	6.6 / 70.4
5.2	15.5 / 166.3	13.6 / 146.4	11.4 / 122	9.8 / 104.6	8.5 / 91.5	6.8 / 73.2
5.4	16.1 / 172.7	14.2 / 152.0	11.8 / 126.7	10.1 / 108.6	8.9 / 95	7.1 / 76
5.6	16.7 / 179.1	14.7 / 157.6	12.3 / 131.4	10.5 / 112.6	9.2 / 98.5	7.4 / 78.8
5.8	17.3 / 185.5	15.2 / 163.3	12.7 / 136.1	10.9 / 116.6	9.5 / 102.1	7.6 / 81.7
6	17.9 / 191.9	15.7 / 168.9	13.1 / 140.8	11.3 / 120.7	9.9 / 105.6	7.9 / 84.5
6.2	18.5 / 198.3	16.3 / 174.5	13.6 / 145.4	11.6 / 124.7	10.2 / 109.1	8.2 / 87.3
6.4	19.1 / 204.7	16.8 / 180.2	14 / 150.1	12 / 128.7	10.5 / 112.6	8.4 / 90.1
6.6	19.7 / 211.1	17.3 / 185.8	14.4 / 154.8	12.4 / 132.7	10.8 / 116.1	8.7 / 92.9
6.8	20.3 / 217.5	17.8 / 191.4	14.9 / 159.5	12.7 / 136.7	11.2 / 119.6	8.9 / 95.7
7	20.8 / 223.9	18.4 / 197.0	15.3 / 164.2	13.1 / 140.8	11.5 / 123.2	9.2 / 98.5
7.2	21.4 / 230.3	18.9 / 202.7	15.7 / 168.9	13.5 / 144.8	11.8 / 126.7	9.5 / 101.4
7.4	22.0 / 236.7	19.4 / 208.3	16.2 / 173.6	13.9 / 148.8	12.1 / 130.2	9.7 / 104.2
7.6	22.6 / 243.1	19.9 / 213.9	16.6 / 178.3	14.2 / 152.8	12.5 / 133.7	10 / 107

NOTICE

- (1) H₀ is the release height, H_{inst} is the installation height, H₀ is higher than H_{inst}.
- (2) H is the floor-to-ceiling height of the room.
- (3) If the actual releasable charge is not exactly equal to the value in the table, the larger releasable charge in the table need to be taken.
- (4) If the actual H is not exactly equal to the value in the table, the smaller H in the table need to be taken.
- (5) This manual is only applicable to a single room.
- (6) Correct the minimum room area of the space A_{min} by multiplying by an altitude adjustment factor (AF) based on for building site ground level altitude (H_{alt}) in meters.

Multi Variable Air Conditioners Wall Mounted Type Indoor Unit

Halt	0	200	400	600	800	1000	1200	1400	1600
AF	1.00	1.00	1.00	1.00	1.02	1.05	1.07	1.10	1.12
Halt	1600	1800	2000	2200	2400	2600	2800	3000	3200
AF	1.12	1.15	1.18	1.21	1.25	1.28	1.32	1.36	1.40

(7) The minimum airflow is 240m³/h(8475.5ft³/h).

(8) "LEAK DETECTION SYSTEM installed. Unit must be powered except for service."

2.5 Calculation Method of Releasable Charge (m_{REL})

The outdoor unit is equipped with automatic refrigerant cut-off valves. When the indoor unit detects refrigerant leakage, the cut-off valves will cut off the refrigerant of the outdoor unit. The releasable charge (m_{REL}) refers to the total amount of refrigerant remaining in all indoor units and pipeline that may leak into the room.

$m_{REL} = m_1$ of all indoor units in the system + m_2 of all pipeline in the system + 0.204kg

If the calculated m_{REL} is larger than the system refrigerant amount (including the default refrigerant of outdoor unit and the additional refrigerant charge), the system refrigerant amount should be used as m_{REL}.

m₁ of high pressure wall mounted type indoor unit is shown in the following table. m₁ of other indoor units refer to corresponding Owner's Manual.

Unit: kg

Indoor Unit	m ₁ of single indoor unit
GMV-ND06G/NhA1C-T(U)	0.20
GMV-ND07G/NhA1C-T(U)	
GMV-ND09G/NhA1C-T(U)	
GMV-ND06G/NhA3C-T(U)	
GMV-ND07G/NhA3C-T(U)	
GMV-ND09G/NhA3C-T(U)	
GMV-ND12G/NhA1C-T(U)	0.17
GMV-ND14G/NhA1C-T(U)	
GMV-ND12G/NhA3C-T(U)	
GMV-ND14G/NhA3C-T(U)	
GMV-ND18G/NhA1C-T(U)	0.39
GMV-ND24G/NhA1C-T(U)	
GMV-ND18G/NhA3C-T(U)	
GMV-ND24G/NhA3C-T(U)	

All pipelines in the system are divided into three types A/B/C according to pipe dimension. Count the total pipe length of each type and find out m₂ of corresponding type in the table below. Add up all m₂ of each type to obtain the m₂ of the system.

m₂ of pipeline:

Pipe Type	A	B	C	
Gas Pipe mm (inch)	15.9 (5/8)	12.7 (1/2)	9.52 (3/8)	
Liquid Pipe mm (inch)	9.52 (3/8)	6.35 (1/4)	6.35 (1/4)	
Total Pipe Length m (feet)	5 (16-3/8)	0.27	0.11	0.10
	10 (32-13/16)	0.54	0.22	0.20
	15 (49-3/16)	0.80	0.33	0.29
	20 (65-5/8)	1.07	0.43	0.39
	25 (82)	1.33	0.54	0.49
	30 (98-7/16)	1.60	0.65	0.58
	35 (114-13/16)	1.87	0.75	0.68
	40 (131-1/4)	2.13	0.86	0.78

Multi Variable Air Conditioners Wall Mounted Type Indoor Unit

Pipe Type		A	B	C
Total Pipe Length m (feet)	45 (147-5/8)	2.40	0.97	0.87
	50 (164-1/16)	2.66	1.07	0.97
	55 (180-7/16)	2.93	1.18	1.07
	60 (196-7/8)	3.20	1.29	1.16
	65 (213-1/4)	3.46	1.39	1.26
	70 (229-11/16)	3.73	1.50	1.36
	75 (246-1/16)	3.99	1.61	1.45
	80 (262-7/16)	4.26	1.71	1.55
	85 (278-7/8)	4.53	1.82	1.65
	90 (295-1/4)	4.79	1.93	1.74
	95 (311-11/16)	5.06	2.03	1.84
	100 (328-1/16)	5.32	2.14	1.93

For example:

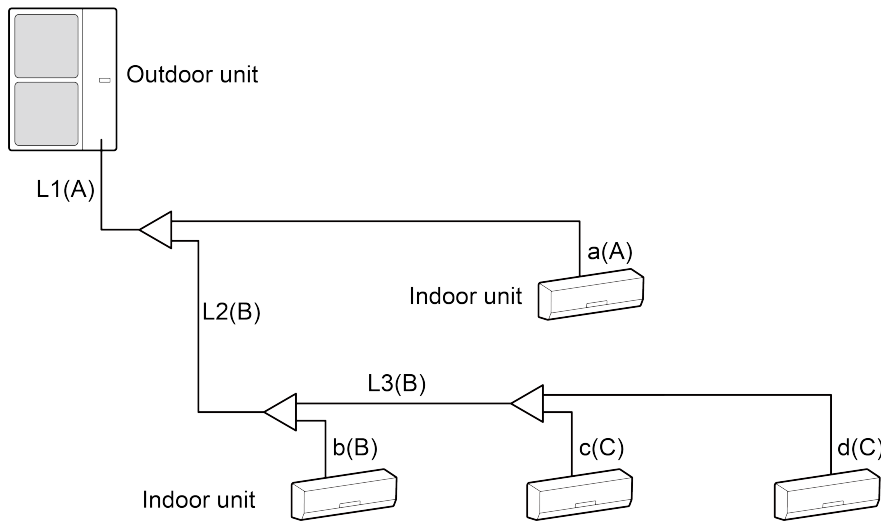

Fig.2.2

There are four indoor units in the system:

GMV-ND24G/NhA1C-T(U)*1 and GMV-ND12G/NhA1C-T(U)*3.

The total length of type A pipeline L1+a is 20m(65.6ft). m² of type A is 1.07kg.

The total length of type B pipeline L2+L3+b is 30m(98.4ft). m² of type B is 0.65kg.

The total length of type C pipeline c+d is 10m(32.8ft). m² of type C is 0.20kg.

The system refrigerant amount is 7kg.

The releasable charge (m_{REL}) should be calculated as below:

$$m_1 = 0.39 + 0.17 * 3 = 0.90 \text{ kg}$$

$$m_2 = 1.07 + 0.65 + 0.20 = 1.92 \text{ kg}$$

$$m_{REL} = 0.90 \text{ kg} + 1.92 \text{ kg} + 0.204 \text{ kg} = 3.024 \text{ kg}$$

For 3 meters high room, the room area must not less than 6.6m² (70.4ft²). If the room area is less than 6.6m² (70.4ft²), measures need to be taken to make the room area meet the requirements, such as changing the piping design of the system to reduce the m_{REL}.

3 Installation Instruction

3.1 Location for Installation

- (1) The appliance shall not be installed in the laundry.
- (2) The indoor unit should be installed at 2.5m(8.2ft) or higher above the floor.
- (3) The top holder must be strong enough to support unit's weight.
- (4) Drain pipe can drain water out easily.
- (5) There is no obstacle at inlet or outlet. Please ensure good air circulation.
- (6) Keep the unit away from heating source, inflammable gas or smoke.

3.2 Schematic Diagram of Installation Spaces

Unit: mm(inch)

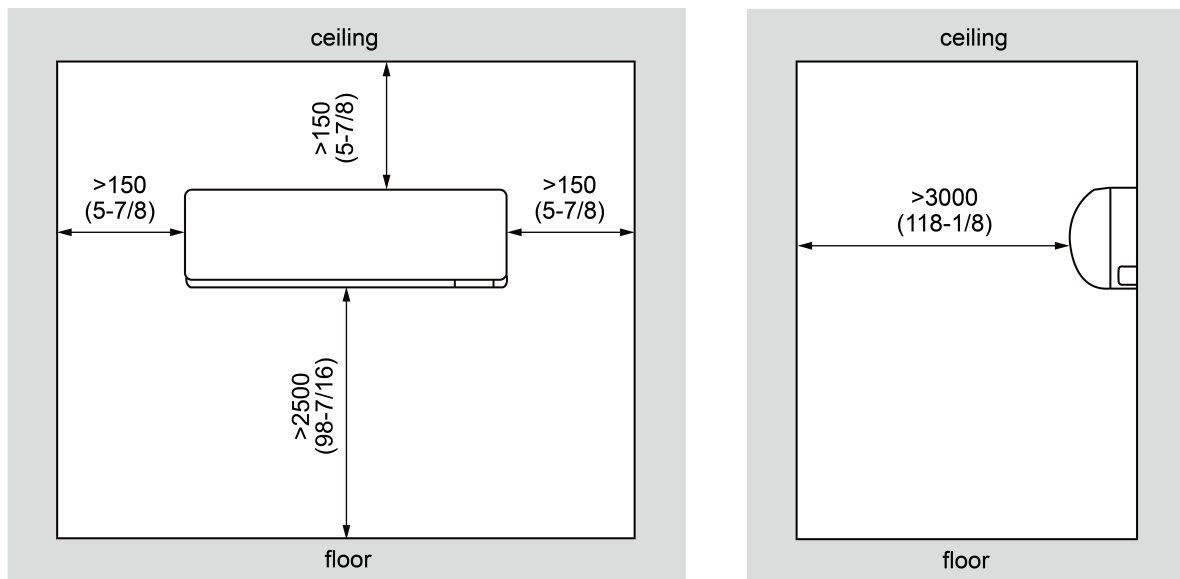

Fig. 3.1

NOTICE	
(1)	The unit shall be installed by the professional personnel according to this installation instruction to ensure proper use.
(2)	Please contact the local Gree appointed service center before installation. Any malfunction caused by the unit that is not installed by the Gree appointed service center would probably not be dealt with on time because of the inconvenience of the business contact.
(3)	It should be guided under the professional personnel when the air conditioner unit is moved to other place.
(4)	Maintenance/service to be done by specialized personnel, mandated by the manufacturer or authorized representative.
(5)	This appliance is intended to be used by expert or trained users in shops, in light industry and on farms or for commercial use by lay persons.
(6)	This unit is a partial unit air conditioner, complying with partial unit requirements of this International standard and must only be connected to other units that have been confirmed as complying to corresponding partial unit requirements of this international standard.
(7)	This unit shall only be connected to an appliance suitable for the same refrigerant.

3.3 Requirements for Communication Line

NOTICE If the unit is installed in the place with strong electromagnetic interference, shielded wire must be applied on the communication wire between indoor unit and wired controller. Twisted pair line with shielding function must be applied on the communication wire between indoor unit and indoor unit (outdoor unit).

3.3.1 Select Communication Line for Indoor Unit and Wired Controller

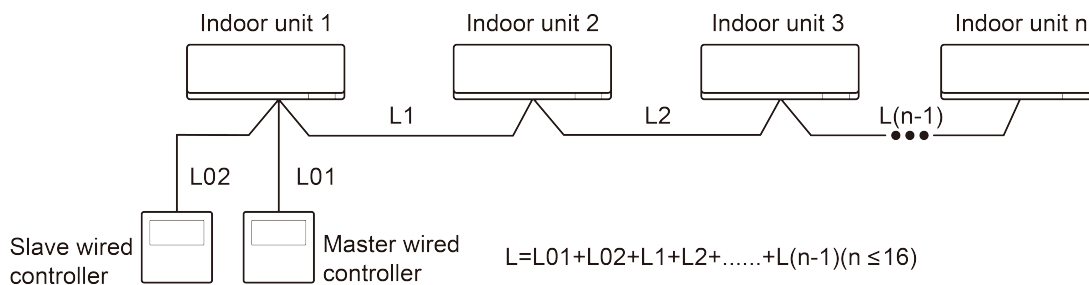

Fig. 3.2

Material type	Total length of communication line between indoor unit and wired controller L	Wire size (mm ² /AWG)	Remarks
Light/Ordinary polyvinyl chloride sheathed cord.	$L \leq 250\text{m}$ ($L \leq 820\text{-}1/5\text{feet}$)	$2 \times 0.75 \sim 2 \times 1.25$ ($2 \times \text{AWG}18 \sim 2 \times \text{AWG}16$)	(1) Total length of communication line can't exceed 250m (820-1/5feet). (2) The cord shall be Circular cord (the cores shall be twisted together). (3) If unit is installed in places with intense magnetic field or strong interference, it is necessary to use shielded wire. (4) The average length of the communication line between indoor unit and wired controller is 15 meters.

3.3.2 Select Communication Line for Indoor Unit and Indoor Unit (Outdoor Unit)

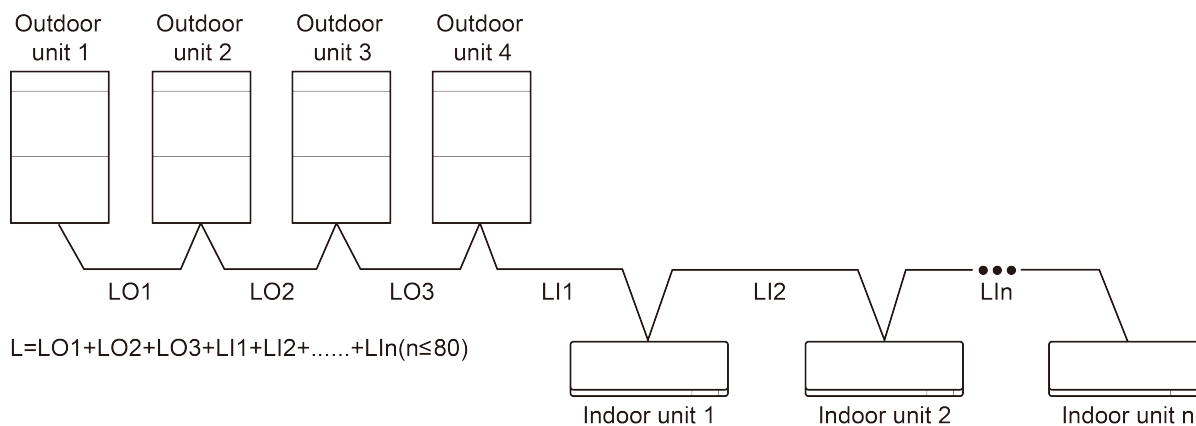

Fig. 3.3

Material Type	Total Length L of Communication Cable between Indoor Unit and Indoor (Outdoor) Unit	Wire size (mm ² /AWG)	Remarks
Light/Ordinary polyvinyl chloride sheathed cord.	$L \leq 1000\text{m}$ ($L \leq 3280\text{-}5/6\text{feet}$)	$\geq 2 \times 0.75$ ($\geq 2 \times \text{AWG}18$)	(1) If the wire diameter is enlarged to $2 \times 1 \text{ mm}^2$ ($2 \times \text{AWG}16$), the total communication line length can reach 1500 m (4921-1/4feet). (2) The cord shall be Circular cord (the cores shall be twisted together). (3) If unit is installed in places with intense magnetic field or strong interference, it is necessary to use shielded wire. (4) The average length of communication line between units is 12.5 meters.

3.4 Electric Installation

Model	Power Supply	MCA(A)	MOP(A)
GMV-ND06G/NhA1C-T(U) GMV-ND07G/NhA1C-T(U) GMV-ND09G/NhA1C-T(U) GMV-ND06G/NhA3C-T(U) GMV-ND07G/NhA3C-T(U) GMV-ND09G/NhA3C-T(U)	208/230V-1ph-60Hz	0.9	15
GMV-ND12G/NhA1C-T(U) GMV-ND14G/NhA1C-T(U) GMV-ND18G/NhA1C-T(U) GMV-ND24G/NhA1C-T(U) GMV-ND12G/NhA3C-T(U) GMV-ND14G/NhA3C-T(U) GMV-ND18G/NhA3C-T(U) GMV-ND24G/NhA3C-T(U)	208/230V-1ph-60Hz	1.1	15

NOTICE

- (1) Use copper wire only as unit's power cord. Operating temperature should be within its rated value.
- (2) If the power cord is more than 15m(590-1/2 inch) long, please increase properly the sectional area of power cord to avoid overload, which may cause accident.
- (3) Above selection requirements: Power cord size is based on BV single-core wire (2~4pc) at 40°C (104°F) ambient temperature when laying across plastic pipe. Air switch is D type and used at 40°C (104°F). If actual installation condition varies, please lower the capacity appropriately according to the specifications of power cord and air switch provided by manufacturer.
- (4) Install cut-off device near the unit. The minimum distance between each stage of cut-off device should be 3mm (1/8 inch) (The same for both indoor unit and outdoor unit).
- (5) Install cut-off device near the unit. The minimum distance between each stage of cut-off device should be 3mm (The same for both indoor unit and outdoor unit).
- (6) Continuous air circulation required for proper functioning. Unit must be powered except for service.

4 Installation Instructions

⚠ WARNING

All phases of this installation must conform to NATIONAL, STATE AND LOCAL CODES. If it is required for additional information, please contact your local distributor.

⚠ WARNING

A brazed, welded, or mechanical connection shall be made before opening the valves to permit refrigerant to flow between the REFRIGERATING SYSTEM parts. A vacuum valve shall be provided to evacuate the interconnecting pipe or any uncharged REFRIGERATING SYSTEM part.

4.1 Installation of Indoor Unit

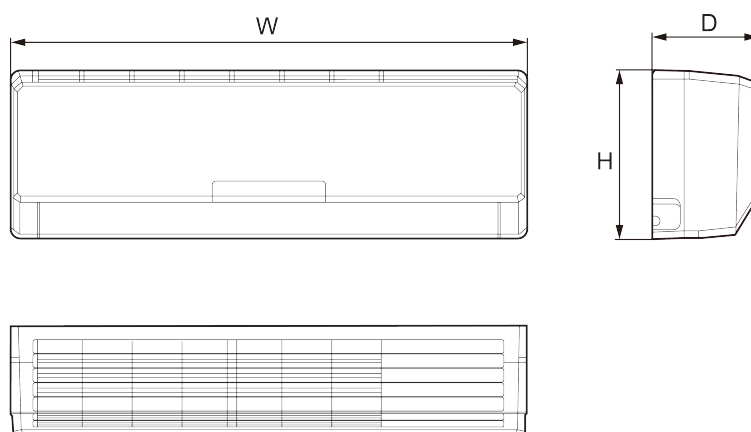

Fig. 4.1

Below are dimensions of W, H, D for different models:

Unit: mm(inch)

Model	Item	W	H	D
GMV-ND06G/NhA1C-T(U) GMV-ND07G/NhA1C-T(U) GMV-ND09G/NhA1C-T(U) GMV-ND06G/NhA3C-T(U) GMV-ND07G/NhA3C-T(U) GMV-ND09G/NhA3C-T(U)		867(34-1/8)	276(10-7/8)	206(8-1/8)
GMV-ND12G/NhA1C-T(U) GMV-ND14G/NhA1C-T(U) GMV-ND12G/NhA3C-T(U) GMV-ND14G/NhA3C-T(U)		978(38-1/2)	333(13-1/8)	248(9-3/4)
GMV-ND18G/NhA1C-T(U) GMV-ND24G/NhA1C-T(U) GMV-ND18G/NhA3C-T(U) GMV-ND24G/NhA3C-T(U)		1116(43-15/16)	333(13-1/8)	248(9-3/4)

4.2 The Installation of the Rear Panel

Unit: mm(inch)

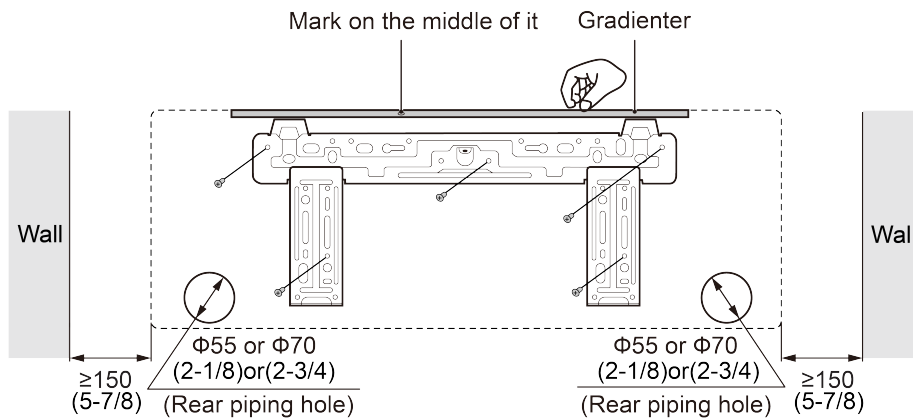

Fig. 4.2

- (1) Find the horizontal position by the spirit level; since the drainage pipe is on the left side, it is necessary to adjust the rear panel to make its left side a little bit lower.
- (2) Fix the rear panel on the wall by bolts.
- (3) After installing the rear panel, pull it by hands to check if it is secured enough. The hang panel should support the weight of an adult (60kg), and the weight shared by every bolt should be fairly even.
- (4) The diameter showed in Fig. 4.2 is 55mm(2-1/8inch) or 70mm(2-3/4inch).

4.3 Preparation of the Piping Hole

- (1) Make the piping hole (55mm(2-1/8inch) or 70mm(2-3/4inch)) in the wall at a slight downward slant to the outdoor side. The center of the hole should be determined referring to Fig. 4.2.
- (2) Insert the piping-hole sleeve into the hole to prevent the connected piping and wiring from being damaged when passing through the hole.

4.4 Installation of the Drainage Pipe

- (1) For proper draining, the drain hose should be placed at a downward sloping.

- (2) Do not wrench or bend the drain hose or flood its end by water.
- (3) Wrap the drain hose with heat resistant material.
- (4) It is not allowed to connect the condensate drain pipe into waste pipe or other pipelines which are likely to produce corrosive or peculiar smell to prevent the smell from entering indoors or corrupt the unit.
- (5) It is not allowed to connect the condensate drain pipe into rain pipe to prevent rain water from pouring in and cause property loss or personal injury.
- (6) Condensate drain pipe should be connected into special drain system for air conditioner.

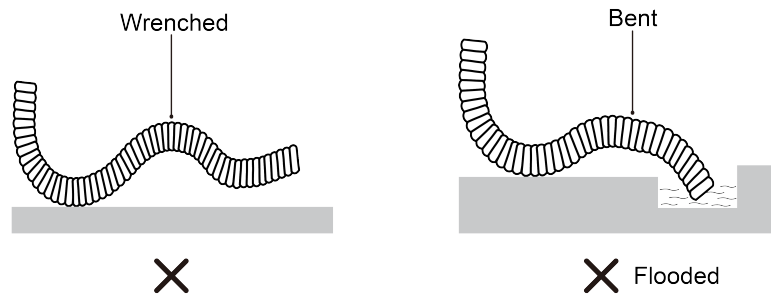

Fig. 4.3

4.5 Installation the Connection Pipes

⚠ WARNING

- (1) Mechanical connectors used indoors shall comply with ISO 14903. When mechanical connectors are reused indoors, sealing parts shall be renewed.
- (2) Pipework shall be protected from physical damage.
- (3) Installation of pipework shall be kept to a minimum space required.
- (4) Do not re-use joints and copper gaskets which have been used already.
- (5) Joints made in installation between parts of refrigerant system shall be accessible for maintenance purposes.
- (6) Install the refrigerant piping or components in a position where they are unlikely to be exposed to any substance which may corrode components containing refrigerant, unless the components are constructed of materials that are inherently resistant to corrosion or are suitably protected against corrosion.
- (7) After completion of field piping for split systems, the field pipework shall be pressure tested with an inert gas and then vacuum tested prior to refrigerant charging, according to the following requirements; field-made refrigerant joints indoors shall be tightness tested. The test method shall have a sensitivity of 5 grams per year of refrigerant or better under a pressure of at least 0.25 times the maximum allowable pressure. No leak shall be detected.

Connect the ends of the connection pipe with two leading pipes, and then tighten the joint nuts tightly.

Connect the connect pipe with the two relative leading pipe, tie the nut on tie –in of the connect pipe tightly.

NOTICE

- (1) Be careful in bending the connection pipes, or you would damage the pipes.
- (2) If the tightening torque for the flare nut is too great, leakage would happen.

5 Wiring Work**⚠ WARNING**

Before obtaining access to terminals, all supply circuits must be disconnected.

NOTICE

- (1) Units must be earthed securely, or it may cause electric shock.
- (2) Please carefully read the wiring diagram before carry out the wiring work, incorrect wiring could cause malfunction or even damage the unit.
- (3) The unit should be powered by independent circuit and specific socket.
- (4) The wiring should be in accordance with related regulations in order to ensure the units reliable running.
- (5) Install circuit breaker for branch circuit according to related regulations and electrical standards.
- (6) Keep cable away from refrigerant pipings, compressor and fan motor.
- (7) The communication wires should be separated from power cord and connection wire between indoor unit and outdoor unit.
- (8) Adjust the static pressure via wired controller according to site circumstance.
- (9) Field operation and installation specifications to meet NFPA 70.

5.1 Connect Cables and Terminals of Wiring Board

Connection of Wire and Patch Board Terminal.

(1) The connection of wire (as shown in Fig. 5.1).

- 1) Strip about 25mm(1inch) insulation of the wire end by stripping and cutting tool.
- 2) Remove the wiring screws on the terminal board.
- 3) Shape the tail of wire into ring by needle nose plier, and keep the gauge of ring in accordance with screw.
- 4) Use the screwdriver for tightening the terminal.

(2) The connection of stranded wire (as shown in Fig. 5.2).

- 1) Strip about 10mm(3/8inch) insulation of the end of stranded wire by stripping and cutting tool.
- 2) Loosen the wiring screws on terminal board.
- 3) Insert the wire into the ring tongue terminal and tighten by crimping tool.
- 4) Use the screwdriver for tightening the terminal.

Unit: mm(inch)

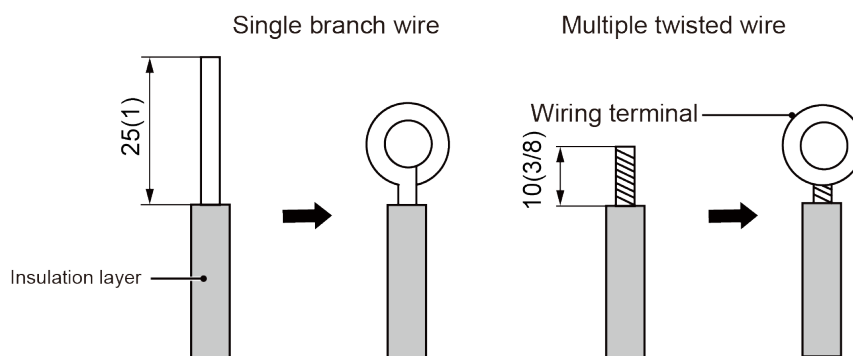

Fig. 5.1

Fig. 5.2

5.2 Power Cord Connection

NOTE

All indoor units must be unified of power supply so that they can be powered ON/OFF at the same time.

If it's with a plug, the power socket must be installed the place where is within your reach.

If the supply cord is damaged, it must be replaced by the manufacturer, its service agent or similarly qualified persons in order to avoid a hazard.

That the appliance shall be installed in accordance with national wiring regulations.

This appliance incorporates an earth connection for functional purposes only.

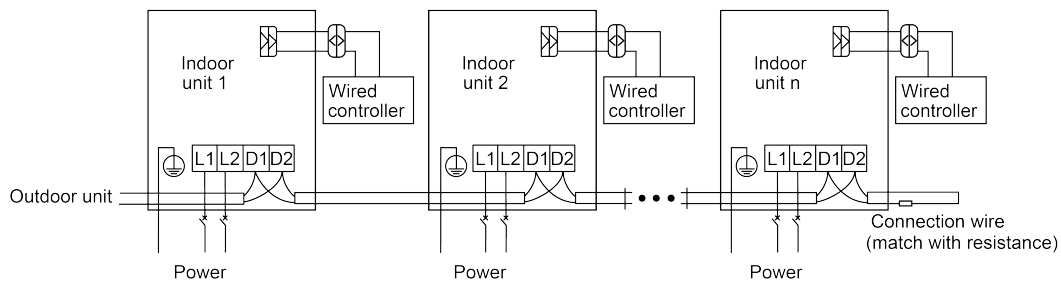

Fig. 5.3

For units with single-phase power supply.

- (1) Detach the electric box lid.
- (2) Let the power cord pass through the wiring through-holes.
- (3) Connect the power cord to the L1, L2 terminals and the grounding screw.
- (4) Fix the power card with wiring clamp.

5.3 Connection of Communication Line of IDU and ODU

- (1) Open the cover of electric box of indoor unit.
- (2) Let the communication cables laid out through cabling through, conduit tube or cable channel.
- (3) Connect the communication line to terminal D1 and D2 on the 4-digit wiring board of indoor unit, as shown in Fig. 5.4

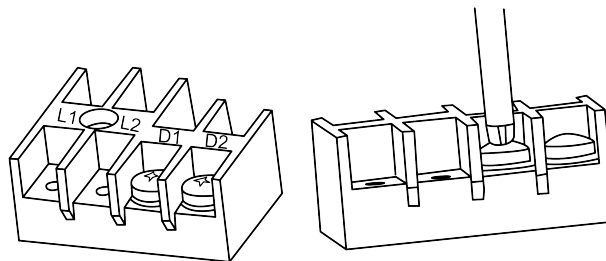

Fig. 5.4

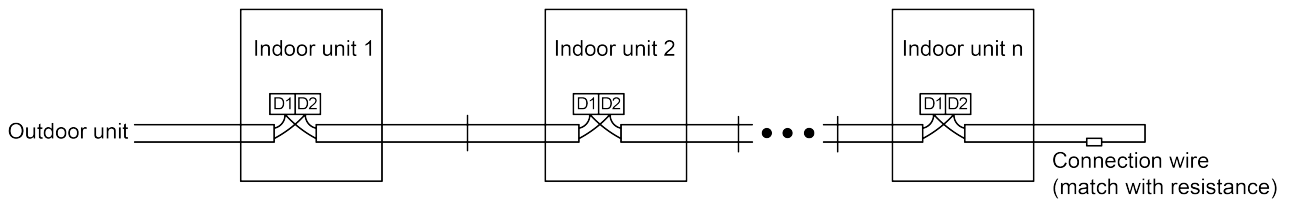

Fig. 5.5

- (4) Secure the communication line with the wire clamp on the electric box.
- (5) In order to ensure the reliability of communication between IDU and ODU and the communication among each IDU, add a matched resistance (supplied in a package before ex-factory) on the wiring board of the last indoor unit in a series connection. The matched resistance should be connected in parallel between terminal screw D1 and D2, as shown in Fig. 5.5

5.4 Illustrate for Connection of Wired Controller and Indoor Units Network

- (1) Communication wire of indoor unit and outdoor unit (or indoor unit) is connected to D1, D2.
- (2) Connect the wire of wired controller with the terminal of indoor unit.
- (3) One indoor unit can connect two wired controllers that must be set as master one and slave one.
- (4) One wired controller can control 16 indoor units in maximum at the same time.

NOTICE

- | |
|--|
| NOTICE |
| (1) The type of indoor units must be the same if they are controlled by the same wired controller. |
| (2) When the indoor unit is controlled by two wired controllers, the addresses of the two wired controllers should be different through address setting. Address 1 is for main controller; Address 2 is for slave controller. Detailed setting please refer to the instruction manual of wired controller. |

5.5 Installation of the Indoor Unit

⚠ WARNING

- ① Only auxiliary devices approved by the appliance manufacturer or declared suitable with the refrigerant shall be installed in Indoor Unit.
 - ② Do NOT install operating ignition sources (example: open flames, an operating gas appliance or an operating electric heater) in Indoor Unit.
 - ③ No auxiliary devices, which may be a potential ignition source, are installed in Indoor Unit (example: hot surfaces with a temperature exceeding 700°C and electric switching device).
- (1) When routing the piping and wiring from the left or right side of the indoor unit, it is necessary to cut off the tailings of the pipe left on the holder of the unit.
 - (2) Let the tubing and cord pass through the piping hole after tied up (refer to Fig. 5.6).
 - (3) Hang the claw behind the indoor unit on the pothook on the wall panel, and move the unit left and right to check if the body is firm.
 - (4) Guarantee that the installation height of the indoor unit should be 2.5m(8-1/4feet) above the floor.

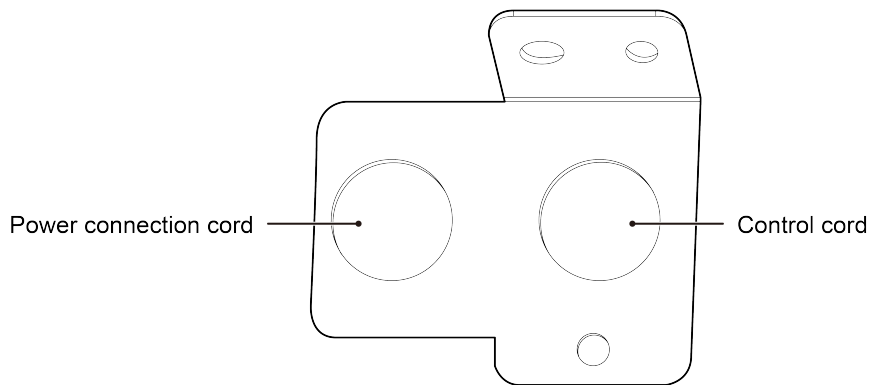

Fig. 5.6

6 The Best Usage Method

NOTICE

Do not pour water to unit or clean it by water, otherwise a malfunction or electric shock may happen.

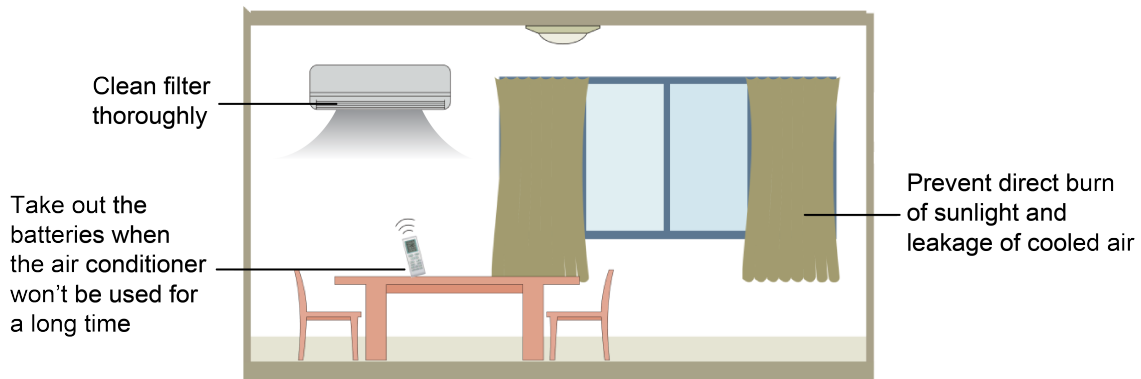

Fig. 6.1

- (1) Adjust to proper indoor temperature; too cool of indoor temperature is not good for health.
- (2) Adjust the set temperature properly in proper to prevent electricity wasting. It is better to control the difference of the indoor and outdoor temperatures within 5°C (41°F).
- (3) The better effect will be maintained by adjusting the guide louver downward for heating and horizontal for cooling.
- (4) When the air conditioner is running, don't open windows or doors for long time, otherwise the efficiency of unit will be lowered.
- (5) Prevent the cooled air blowing to body directly for long time and making indoor temperature too low, for it is bad for health.
- (6) Do not mangle the power cord and the communication cord. The damaged power cord and communication cord can only be replaced by the specified ones.
- (7) This air conditioner cannot be used for drying clothes and refrigerating food, etc.

7 Maintenance Method

NOTICE	
(1)	Do not turn off the unit and cut off the main power supply when cleaning the air conditioner to avoid electric shock or injury.
(2)	Stand at solid table when cleaning the unit.
(3)	Do not clean the unit with hot water whose temperature is higher than 45°C (113°F) to prevent fade or deformation.
(4)	Do not dry the filters by fire, or it may catch fire or become deformed.
(5)	Volatile liquid like thinner or gasoline would damage the appearance of the air conditioner (Only soft dry cloth and wet cloth moistened with neutral detergent could be used to clean the surface panel of the air conditioner).
(6)	Please contact after-sales service staff if there is abnormal situation.

7.1 About the Refrigerant Leakage Sensor

- (1) The R32 refrigerant leakage sensor must be replaced after malfunction or at the end of its lifetime. Only authorized persons may replace the sensor. Only refrigerant leakage sensor of the specified manufacturer can be used.
- (2) The sensor has a lifetime of 15 years. At the end of sensor lifetime or when the sensor faults, the indoor unit or wired controller displays error code "yd", and emits an alarm sound. The alarm can be canceled by operating the "On/Off" button of the wired controller or remote control. The indoor unit fan will keep running and the system can not operate until the sensor is replaced. Please contact our designated dealer or local service center to replace the sensor.
- (3) The R32 refrigerant leakage sensor is a semiconductor detector which may incorrectly detect substances other than R32 refrigerant. Avoid using chemical substances (e.g. organic solvents, hair spray, paint) in high concentrations, in the close proximity of the indoor unit because this may cause misdetection of the R32 refrigerant leakage sensor.
- (4) When the sensor detects refrigerant leak, the indoor unit or wired controller displays error code "yb", and emits an alarm sound. The alarm can be canceled by operating the "On/Off" button of the wired controller or remote control. The indoor unit fan will keep running and the system can not operate until the leakage is repaired. Please contact our designated dealer or local service center.
- (5) If the indoor unit reports a refrigerant leak and returns to normal after a while, it may be a misdetection caused by other chemical substances.

7.2 Cleaning Panel

Do not take down the panel before cleaning.

- (1) Pull along the direction of arrows to take down the panel.
- (2) Clean the panel.

Clean it with a soft-hair brush, water and neutral cleaning fluid, and then dry it.

- (3) Install the panel.

As shown in Fig. 7.1, install the stands of both ends of the panel into the slot and put the middle rotating shaft into the groove, then place the panel and clasp back along the arrow direction.

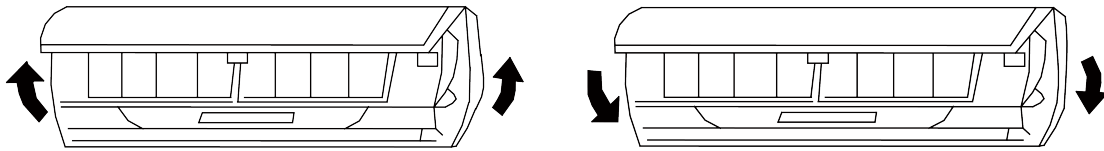

Fig. 7.1

7.3 Cleaning the Air Filters

Clean it once every 3 months; when the usage environment has lots of dust, it should be cleaned more frequently.

- (1) Take down the air filter.

As shown in Fig. 7.2 open the surface panel by holding the both ends of groove along the arrow direction, and then take the air filter out downward.

- (2) Clean the filter.

Use cleaner or water to wash the filter; if the filter is too dirty (like oil stain on it), warm water (lower than 45°C(113°F)) with neutral detergent can be used, then dry it in the shade.

NOTICE

- | |
|---|
| (1) Do not clean the filter by hot water higher than 45°C (113°F) for preventing fade or deformation. |
| (2) Do not burn it on fire or the filter would catches fire or deformation. |

- (3) Do not clean the filter by hot water higher than 45°C (113°F) for preventing fade or deformation.

Do not burn it on fire or the filter would catches fire or deformation.

- (4) Install air filter.

Install the air filter properly along the arrow direction, making the side marked “Front” facing yourself and then place the panel back.

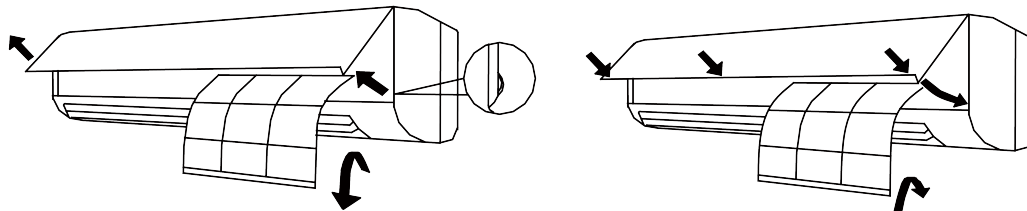

Fig. 7.2

7.4 Check before the Usage Season

- (1) Check if there is blockage in the inlet or outlet vent of the air conditioner.
- (2) Check if the earth wire is earthed reliably.
- (3) Check if the batteries in the wireless remote controller have been replaced.
- (4) Check if the air filter has been installed properly.

In order to start up the air conditioner smoothly after it has been turned off for a long time period, energize the unit 8 hours before turning it on.

7.5 Check after the Usage Season

- (1) Clean filter and body of air conditioner.
- (2) Cut off the main power supply of air conditioner.

8 Table of Error Codes for Indoor Unit

Error Code	Content	Error Code	Content	Error Code	Content
L0	Indoor Unit Error	L9	Quantity Of Group Control Indoor Units Setting Error	dL	Outlet Air Temperature Sensor Error
L1	Indoor Fan Protection	LA	Indoor Units Incompatibility Error	d8	Water Temperature Sensor Error
L2	E-heater Protection	LH	Low Air Quality Warning	d9	Jumper Cap Error
L3	Water Full Protection	LC	Outdoor-Indoor Incompatibility Error	dA	Indoor Unit Network Address Error
L4	Wired Controller Power Supply Error	d1	Indoor Unit Circuit Board Error	dH	Wired Controller Circuit Board Error
L5	Anti-freezing Protection	d3	Ambient Temperature Sensor Error	dC	Capacity DIP Switch Setting Error
L7	No Master Indoor Unit Error	d4	Inlet Pipe Temperature Sensor Error	dE	Indoor Unit CO ₂ Sensor Error
L8	Power Insufficiency Protection	d5	Medium Pipe Temperature Sensor Error	C0	Communication Error
db	Special Code: Project Debugging Code	d6	Outlet Pipe Temperature Sensor Error	AJ	Filter Cleaning Reminding

9 Malfunction Analyzing

WARNING

Do not repair the air conditioner by yourself for the incorrect repair would lead to electric shock or fire. Please contact the service center and have the unit repaired by the specialized personnel. Check the following items before contacting the service center, as it could save your time and cost.

Malfunction Phenomena	Malfunction Analyzing
The air conditioner could not start up just after turned off.	The over load protection switch of the unit makes it run after 3 minutes delay.
Odor gave out when the unit just was turned on.	Odors or cigarette smoke which has been absorbed in is discharged out.
Slight bicker was heard when the unit was running.	This is the sound of the running refrigerant.
Mist came from the air outlet vent when cooling.	Indoor air is cooled rapidly.
Creak sound was heard when the unit was running or after it was turned off.	It is the sound emitted by the expansion of the panel and other parts because of the temperature change.
The air conditioner failed to run.	Is the power supply cut off? Is the power supply connected? Is the circuit protector started aside? Is the voltage too high or too low? If TIMER had been set on the wireless remote controller?
The cooling (heating) effect of the air conditioner was not good.	Is the temperature set properly? Is the inlet, outlet vent of the outdoor unit blocked? Is the air filter too dirty to cause blockage? Are windows and doors closed? Is the air speed too low? Is there other heat source in the room?
The wireless remote controller cannot work.	In the event that the battery is replaced but the wireless remote control still malfunctions, then open the back cover and press "ACL" button to make it normal. When the air conditioner is under abnormal interference or its functions are changed too frequently, then the wireless remote controller would works improperly. At this time, it is available to resume the normal operation through de-energizing and then energizing the wireless controller again. Is the controller within the receiving area? or is there blockage? Check if the voltages of batteries in the wireless remote controller are sufficient; Otherwise change the batteries.

9.1 Service Center

When the following phenomena appeared, please stop operating immediately, cut off the main power supply of the unit and then contact the service center of the air conditioner.

- (1) Harsh sound heard when running.
- (2) The fuse or protector opened frequently.
- (3) Substance or water pulled in the unit involuntarily.
- (4) Water leakage in room.
- (5) Power cord overheated.
- (6) Abnormal odor is given out when running.

9.2 After-sales Service

When quality or other problems arise upon the purchased air conditioner, please contact the local service center.

10 Adjusting Method of the Air Direction

10.1 Adjusting Air Direction Up and Down

- (1) Controlling the guide louver motor by the wireless remote controller can make the guide louver swing up and down, or makes the guide louver stop at a certain angle to have air supplied.
- (2) Press the SWING button on the wireless remote controller to make the guide louver swing up and down; Repress again to stop the operation.

10.2 Adjusting Air Direction Left and Right

Moving the vertical louver left and right can adjust the left and right direction of air outlet, or adjust the air outlet to reach every corner of the room by 3 different outlet directions to make the indoor temperature more even.

11 Unventilated Areas

⚠ WARNING The non-FIXED APPLIANCE shall be stored in an area where the room size corresponds to the room area as specified for operation;

⚠ WARNING The non-FIXED APPLIANCE shall be stored in a room without continuously operating open flames (for example an operating gas appliance) or other POTENTIAL IGNITION SOURCES (for example an operating electric heater, hot surfaces);

⚠ WARNING If appliances with A2L REFRIGERANTS connected via an air conditioner system to one or more rooms are installed in a room with an area less than Amin, that room shall be without continuously operating open flames (for example an operating gas appliance) or other POTENTIAL IGNITION SOURCES (for example an operating electric heater, hot surfaces). A flame-producing device may be installed in the same space if the device is provided with an effective flame arrest;

⚠ WARNING Auxiliary devices which may be a POTENTIAL IGNITION SOURCE shall not be installed in indoor unit. Examples of such POTENTIAL IGNITION SOURCES are hot surfaces with a temperature exceeding 648°C and electric switching devices;

⚠ WARNING That only auxiliary devices approved by the appliance manufacturer or declared suitable with the refrigerant shall be installed in indoor unit. The manufacturer can list in the instructions all approved auxiliary devices by the manufacturer and model number for use with the specific appliance, if those devices have a potential to become an ignition source.

12 Qualification of Worker

The manual shall contain specific information about the required qualification of the working personnel for maintenance, service and repair operations. Every working procedure that affects safety means shall only be carried out by competent persons. The training of these procedures is carried out by national training organizations or manufacturers that are accredited to teach the relevant national competency standards that may be set in legislation. The achieved competence should be documented by a certificate.

Examples for such working procedures are:

- (1) breaking into the refrigerating circuit;
- (2) opening of sealed components;
- (3) opening of ventilated enclosures.

13 Transportation, Marking and Storage for Units that Employ Flammable Refrigerants

13.1 General

The following information is provided for units that employ FLAMMABLE REFRIGERANTS.

13.2 Transport of Equipment Containing Flammable Refrigerants

Attention is drawn to the fact that additional transportation regulations may exist with respect to equipment containing flammable gas. The maximum number of pieces of equipment or the configuration of the equipment permitted to be transported together will be determined by the applicable transport regulations.

13.3 Marking of Equipment Using Signs

Signs for similar appliances used in a work area are generally addressed by local regulations and give the minimum requirements for the provision of safety and/ or health signs for a work location.

All required signs are to be maintained and employers should ensure that employees receive suitable and sufficient instruction and training on the meaning of appropriate safety signs and the actions that need to be taken in connection with these signs.

The effectiveness of signs should not be diminished by too many signs being placed together.

Any pictograms used should be as simple as possible and contain only essential details.

13.4 Disposal of Equipment Using Flammable Refrigerants

See national regulations.

13.5 Storage of Equipment/Appliances

The storage of the appliance should be in accordance with the applicable regulations or instructions, whichever is more stringent.

13.6 Storage of Packed (Unsold) Equipment

Storage package protection should be constructed in such a way that mechanical damage to the equipment inside the package will not cause a leak of the REFRIGERANT CHARGE.

The maximum number of pieces of equipment permitted to be stored together will be determined by local regulations.

14 Information on Servicing

14.1 General

The manual shall contain specific information for service personnel according to 14.2 to 14.10.

14.2 Checks to the Area

Prior to beginning work on systems containing FLAMMABLE REFRIGERANTS, safety checks are necessary to ensure that the risk of ignition is minimized. For repair to the REFRIGERATING SYSTEM, 14.3 to 14.7 shall be completed prior to conducting work on the system.

14.3 Work Procedure

Work shall be undertaken under a controlled procedure so as to minimize the risk of a flammable gas or vapor being present while the work is being performed.

14.4 General Work Area

All maintenance staff and others working in the local area shall be instructed on the nature of work being carried out. Work in confined spaces shall be avoided.

14.5 Checking for Presence of Refrigerant

The area shall be checked with an appropriate refrigerant detector prior to and during work, to ensure the technician is aware of potentially toxic or flammable atmospheres. Ensure that the leak detection equipment being used is suitable for use with all applicable refrigerants, i.e. non-sparking, adequately sealed or intrinsically safe.

14.6 Presence of Fire Extinguisher

If any hot work is to be conducted on the refrigerating equipment or any associated parts, appropriate fire extinguishing equipment shall be available to hand. Have a dry powder or CO₂ fire extinguisher adjacent to the charging area.

14.7 No Ignition Sources

No person carrying out work in relation to a REFRIGERATING SYSTEM which involves exposing any pipe work shall use any sources of ignition in such a manner that it may lead to the risk of fire or explosion. All possible ignition sources, including cigarette smoking, should be kept sufficiently far away from the site of installation, repairing, removing and disposal, during which refrigerant can

possibly be released to the surrounding space. Prior to work taking place, the area around the equipment is to be surveyed to make sure that there are no flammable hazards or ignition risks. "No Smoking" signs shall be displayed.

14.8 Ventilated Area

Ensure that the area is in the open or that it is adequately ventilated before breaking into the system or conducting any hot work. A degree of ventilation shall continue during the period that the work is carried out. The ventilation should safely disperse any released refrigerant and preferably expel it externally into the atmosphere.

14.9 Checks to the Refrigerating Equipment

Where electrical components are being changed, they shall be fit for the purpose and to the correct specification. At all times the manufacturer's maintenance and service guidelines shall be followed. If in doubt, consult the manufacturer's technical department for assistance. The following checks shall be applied to installations using FLAMMABLE REFRIGERANTS:

- (1) The actual REFRIGERANT CHARGE is in accordance with the room size within which the refrigerant containing parts are installed;
- (2) The ventilation machinery and outlets are operating adequately and are not obstructed;
- (3) If an indirect refrigerating circuit is being used, the secondary circuit shall be checked for the presence of refrigerant;
- (4) Marking to the equipment continues to be visible and legible. Markings and signs that are illegible shall be corrected;
- (5) Refrigerating pipe or components are installed in a position where they are unlikely to be exposed to any substance which may corrode refrigerant containing components, unless the components are constructed of materials which are inherently resistant to being corroded or are suitably protected against being so corroded.

14.10 Checks to Electrical Devices

Repair and maintenance to electrical components shall include initial safety checks and component inspection procedures. If a fault exists that could compromise safety, then no electrical supply shall be connected to the circuit until it is satisfactorily dealt with. If the fault cannot be corrected immediately but it is necessary to continue operation, an adequate temporary solution shall be used. This shall be reported to the owner of the equipment so all parties are advised. Initial safety checks shall include:

- (1) That capacitors are discharged: this shall be done in a safe manner to avoid possibility of sparking;
- (2) That no live electrical components and wiring are exposed while charging, recovering or purging the system;
- (3) That there is continuity of earth bonding.

▲ WARNING

Only auxiliary devices approved by the appliance manufacturer or declared suitable with the refrigerant shall be installed in connecting ductwork for duct connected appliances, false ceilings or drop ceilings may be used as a return air plenum if a REFRIGERANT DETECTION SYSTEM is provided in the appliance and any external connections are also provided with a sensor immediately below the return air plenum duct joint.

14.11 Pipe Installation

That pipe-work including piping material, pipe routing, and installation shall include protection from physical damage in operation and service, and be in compliance with national and local codes and standards, such as ASHRAE 15, ASHRAE 15.2, IAPMO Uniform Mechanical Code, ICC International Mechanical Code, or CSA B52. All field joints shall be accessible for inspection prior to being covered or enclosed.

That after completion of field piping for split systems, the field pipework shall be pressure tested with an inert gas and then vacuum tested prior to refrigerant charging, according to the following requirements field-made refrigerant joints indoors shall be tightness tested. The test method shall have a sensitivity of 5 grams per year of refrigerant or better under a pressure of at least 0,25 times the maximum allowable pressure. No leak shall be detected.

The minimum test pressure for the low side of the system shall be the low side design pressure and the minimum test pressure for the high side of the system shall be the high side design pressure, unless the high side of the system, cannot be isolated from the low side of the system in which case the entire system shall be pressure tested to the low side design pressure.

15 Sealed Electrical Components Shall be Replaced

16 Intrinsically Safe Components Must be Replaced

17 Cabling

Check that cabling will not be subject to wear, corrosion, excessive pressure, vibration, sharp edges or any other adverse environmental effects. The check shall also take into account the effects of aging or continual vibration from sources such as compressors or fans.

18 Detection of Flammable Refrigerants

Under no circumstances shall potential sources of ignition be used in the searching for or detection of refrigerant leaks. A halide torch (or any other detector using a naked flame) shall not be used.

The following leak detection methods are deemed acceptable for all refrigerant systems.

Electronic leak detectors may be used to detect refrigerant leaks but, in the case of FLAMMABLE REFRIGERANTS, the sensitivity may not be adequate, or may need re-calibration. (Detection equipment shall be calibrated in a refrigerant-free area.) Ensure that the detector is not a potential source of ignition and is suitable for the refrigerant used. Leak detection equipment shall be set at a percentage of the LFL of the refrigerant and shall be calibrated to the refrigerant employed, and the appropriate percentage of gas (25 % maximum) is confirmed.

Leak detection fluids are also suitable for use with most refrigerants but the use of detergents containing chlorine shall be avoided as the chlorine may react with the refrigerant and corrode the copper pipe-work.

NOTICE Examples of leak detection fluids are:

- (1) Bubble method.
- (2) Fluorescent method agents.

If a leak is suspected, all naked flames shall be removed/extinguished.

If a leakage of refrigerant is found which requires brazing, all of the refrigerant shall be recovered from the system, or isolated (by means of shut off valves) in a part of the system remote from the leak. Removal of refrigerant shall be according to Clause 19.

19 Removal and Evacuation

When breaking into the refrigerant circuit to make repairs-or for any other purpose -conventional procedures shall be used. However, for flammable refrigerants it is important that best practice be followed, since flammability is a consideration. The following procedure shall be adhered to: The refrigerant charge shall be recovered into the correct recovery cylinders if venting is not allowed by local and national codes. For appliances containing flammable refrigerants, the system shall be purged with oxygen-free nitrogen to render the appliance safe for flammable refrigerants. This process might need to be repeated several times.

- safely remove refrigerant following local and national regulations;
 - evacuate;
 - purge the circuit with inert gas (optional for A2L);
 - evacuate (optional for A2L);
 - continuously flush or purge with inert gas when using flame to open circuit;
- and
- open the circuit. Compressed air or oxygen shall not be used for purging refrigerant systems.

For appliances containing flammable refrigerants, refrigerants purging shall be achieved by breaking the vacuum in the system with oxygen-free nitrogen and continuing to fill until the working pressure is achieved, then venting to atmosphere, and finally pulling down to a vacuum (optional for A2L). This process shall be repeated until no refrigerant is within the system (optional for A2L). When the final oxygen-free nitrogen charge is used, the system shall be vented down to atmospheric pressure to enable work to take place.

The outlet for the vacuum pump shall not be close to any potential ignition sources, and ventilation shall be available.

20 Charging Procedures

In addition to conventional charging procedures, the following requirements shall be followed.

- (1) Ensure that contamination of different refrigerants does not occur when using charging equipment.
- (2) Hoses or lines shall be as short as possible to minimize the amount of refrigerant contained in them.

- (3) Cylinders shall be kept in an appropriate position according to the instructions.
- (4) Ensure that the REFRIGERATING SYSTEM is earthed prior to charging the system with refrigerant.
- (5) Label the system when charging is complete (if not already).
- (6) Extreme care shall be taken not to overfill the REFRIGERATING SYSTEM.

Prior to recharging the system, it shall be pressure-tested with the appropriate purging gas. The system shall be leak-tested on completion of charging but prior to commissioning. A follow up leak test shall be carried out prior to leaving the site.

21 Decommissioning

Before carrying out this procedure, it is essential that the technician is completely familiar with the equipment and all its detail. It is recommended good practice that all refrigerants are recovered safely.

Prior to the task being carried out, an oil and refrigerant sample shall be taken in case analysis is required prior to re-use of recovered refrigerant. It is essential that electrical power is available before the task is commenced.

- (1) Become familiar with the equipment and its operation) Isolate system electrically.
- (2) Before attempting the procedure, ensure that:
 - 1) Mechanical handling equipment is available, if required, for handling refrigerant cylinders;
 - 2) All personal protective equipment is available and being used correctly;
 - 3) The recovery process is supervised at all times by a competent person;
 - 4) Recovery equipment and cylinders conform to the appropriate standards.
- (3) Pump down refrigerant system, if possible.
- (4) If a vacuum is not possible, make a manifold so that refrigerant can be removed from various parts of the system.
- (5) Make sure that cylinder is situated on the scales before recovery takes place.
- (6) Start the recovery machine and operate in accordance with instructions.
- (7) Do not overfill cylinders (no more than 80% volume liquid charge).
- (8) Do not exceed the maximum working pressure of the cylinder, even temporarily.
- (9) When the cylinders have been filled correctly and the process completed, make sure that the cylinders and the equipment are removed from site promptly and all isolation valves on the equipment are closed off.
- (10) Recovered refrigerant shall not be charged into another REFRIGERATING SYSTEM unless it has been cleaned and checked.

22 Labeling

Equipment shall be labeled stating that it has been decommissioned and emptied of refrigerant. The label shall be dated and signed. For appliances containing FLAMMABLE REFRIGERANTS, ensure that there are labels on the equipment stating the equipment contains FLAMMABLE REFRIGERANT.

23 Recovery

When removing refrigerant from a system, either for servicing or decommissioning, it is recommended good practice that all refrigerants are removed safely.

When transferring refrigerant into cylinders, ensure that only appropriate refrigerant recovery cylinders are employed. Ensure that the correct number of cylinders for holding the total system charge is available. All cylinders to be used are designated for the recovered refrigerant and labeled for that refrigerant (i.e. special cylinders for the recovery of refrigerant). Cylinders shall be complete with pressure-relief valve and associated shut-off valves in good working order. Empty recovery cylinders are evacuated and, if possible, cooled before recovery occurs.

The recovery equipment shall be in good working order with a set of instructions concerning the equipment that is at hand and shall be suitable for the recovery of the flammable refrigerant. If in doubt, the manufacturer should be consulted. In addition, a set of calibrated weighing scales shall be available and in good working order. Hoses shall be complete with leak-free disconnect couplings and in good condition.

The recovered refrigerant shall be processed according to local legislation in the correct recovery cylinder, and the relevant waste transfer note arranged. Do not mix refrigerants in recovery units and especially not in cylinders. If compressors or compressor oils are to be removed, ensure that they have been evacuated to an acceptable level to make certain that flammable refrigerant does not remain within the lubricant. The compressor body shall not be heated by an open flame or other ignition sources to accelerate this process. When oil is drained from a system, it shall be carried out safely.

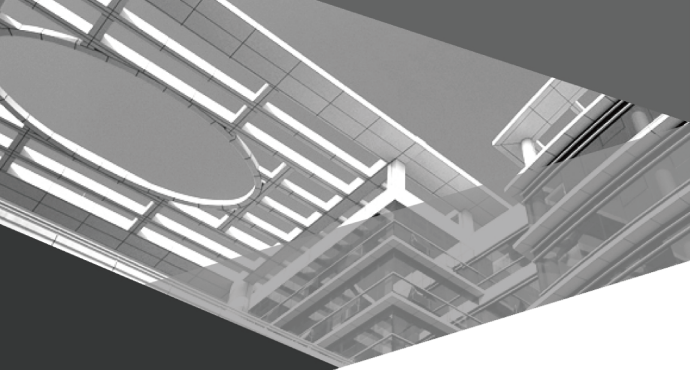

GREE ELECTRIC APPLIANCES, INC. OF ZHUHAI

Add: West Jinji Rd, Qianshan, Zhuhai,Guangdong, China, 519070

Tel: (+86-756) 8522218

Fax: (+86-756) 8669426

E-mail: global@cn.gree.com www.gree.com



600005068966