



Owner's Manual

Original Instructions

Multi Variable Air Conditioners
Air Handler Type Indoor Unit

Models:

GMV-ND12A/NhB-T(U)

GMV-ND18A/NhB-T(U)

GMV-ND24A/NhB-T(U)

GMV-ND30A/NhB-T(U)

GMV-ND36A/NhB-T(U)

GMV-ND42A/NhB-T(U)

GMV-ND48A/NhB-T(U)

GMV-ND54A/NhB-T(U)

GMV-ND60A/NhB-T(U)

Thank you for choosing this product. Please read this Owner's Manual carefully before operation and retain it for future reference.

If you have lost the Owner's Manual, please contact the local agent or visit www.gree.com or send an email to global@cn.gree.com for the electronic version.

GREE ELECTRIC APPLIANCES, INC. OF ZHUHAI

To Users

Thank you for selecting Gree product. Please read this instruction manual carefully before installing and using the product, so as to master and correctly use the product. In order to guide you to correctly install and use our product and achieve expected operating effect, we hereby instruct as below:

- (1) This appliance is not intended for use by persons (including children) with reduced physical, sensory or mental capabilities, or lack of experience and knowledge, unless they have been given supervision or instruction concerning use of the appliance by a person responsible for their safety. Children should be supervised to ensure that they do not play with the appliance.
- (2) In order to ensure reliability of product, the product may consume some power under stand-by status for maintaining normal communication of system and preheating refrigerant and lubricant. If the product is not to be used for long, cut off the power supply; please energize and preheat the unit in advance before reusing it.
- (3) Please properly select the model according to actual using environment, otherwise it may impact the using convenience.
- (4) This product can't be installed at corrosive, inflammable or explosive environment or the place with special requirements, such as kitchen. Otherwise, it will affect the normal operation or shorten the service life of the unit, or even cause fire hazard or serious injury. As for above special places, please adopt special air conditioner with anti-corrosive or anti-explosion function.
- (5) If the product needs to be installed, moved or maintained, please contact our designated dealer or local service center for professional support. Users should not disassemble or maintain the unit by themselves, otherwise it may cause relative damage, and our company will bear no responsibilities.
- (6) All the illustrations and information in the instruction manual are only for reference. In order to make the product better, we will continuously conduct improvement and innovation. If there is adjustment in the product, please subject to actual product.







Exception Clauses

Manufacturer will bear no responsibilities when personal injury or property loss is caused by the following reasons:

- (1) Damage the product due to improper use or misuse of the product.
- (2) Alter, change, maintain or use the product with other equipment without abiding by the instruction manual of manufacturer.
- (3) After verification, the defect of product is directly caused by corrosive gas.
- (4) After verification, defects are due to improper operation during transportation of product.
- (5) Operate, repair, maintain the unit without abiding by instruction manual or related regulations.
- (6) After verification, the problem or dispute is caused by the quality specification or performance of parts and components that produced by other manufacturers.
- (7) The damage is caused by natural calamities, bad using environment or force majeure.

Preface

For correct installation and operation, please read all instructions carefully. Understand these signal words: **DANGER**, **WARNING**, **CAUTION** and **NOTICE**. These words are used with the safety--alert symbol.

 DANGER	This is the safety alert symbol. It is used to alert you to potential personal injury hazards. Obey all safety messages that follow this symbol to avoid possible injury or death.
 WARNING	This mark indicates procedures which, if improperly performed, might lead to the death or serious injury of the user.
 CAUTION	This mark indicates procedures which, if improperly performed, might possibly result in personal harm to the user, or damage to property.
NOTICE	NOTICE is used to address practices not related to personal injury.
	Appliance filled with flammable gas R32.
	Before install the appliance, read the installation manual first.
	Before use the appliance, read the owner's manual first.
	Before repair the appliance, read the service manual first.

 WARNING	
(1)	Do not use means to accelerate the defrosting process or to clean, other than those recommended by the manufacturer.
(2)	The appliance shall be stored in a room without continuously operating ignition sources (for example: open flames, an operating gas appliance or an operating electric heater).
(3)	Do not pierce or burn.
(4)	Be aware that refrigerants might not contain an odour.

This appliance is not intended for use by persons (including children) with reduced physical, sensory or mental capabilities, or lack of experience and knowledge, unless they have been given supervision or instruction concerning use of the appliance by a person responsible for their safety.

Children should be supervised to ensure that they do not play with the appliance.



DISPOSAL: Do not dispose this product as unsorted municipal waste. Collection of such

waste separately for special treatment is necessary.

Contents

1 Safety Notices (Please be sure to abide them)	1
2 Product Introduction	2
2.1 Names of Key Components	2
2.2 Rated Working Condition	2
2.3 The Range of Production Working Temperature	3
2.4 Minimum Room Area	3
2.5 Calculation Method of Releasable Charge (m_{REL})	4
3 Preparations for Installation	6
3.1 Pre-Installation Instruction	6
3.2 Important Safety Instructions	6
3.3 Requirements for Communication Line	8
3.4 Wiring Requirements and Fuse Capacity	9
4 Installation Instructions	10
4.1 Dimension Data	10
4.2 Location	10
4.3 Piping Work	13
4.4 Condensate Removal	14
4.5 Installation of Wired Controller	16
4.6 Ductwork	16
4.7 Electric Heater	16
5 Wiring Work	18
5.1 Connection of Wire and Patch Board Terminal	19
5.2 Power Cord Connection	19
5.3 Connection of Communication Wire between Indoor Unit and Outdoor Unit (or indoor unit)	20
5.4 Connect Communication Wire of Wired Controller	21
5.5 Illustrate for Connection of Wired Controller and Indoor Units Network	21
6 Setting of External Static Pressure	22
7 Routine Maintenance	22
7.1 About the Refrigerant Leakage Sensor	23
7.2 Cleaning of Filter	24
7.3 Maintenance before the Seasonal Use	24
7.4 Maintenance after the Seasonal Use	24
8 Table of Error Codes for Indoor Unit	25
9 Troubleshooting	26
10 Unventilated Areas	26

11 Qualification of Worker	27
12 Transportation, Marking and Storage for Units that Employ Flammable Refrigerants	27
12.1 General.....	27
12.2 Transport of Equipment Containing Flammable Refrigerants	27
12.3 Marking of Equipment Using Signs	27
12.4 Disposal of Equipment Using Flammable Refrigerants	27
12.5 Storage of Equipment/Appliances	27
12.6 Storage of Packed (Unsold) Equipment	28
13 Information on Servicing	28
13.1 General.....	28
13.2 Checks to the Area	28
13.3 Work Procedure.....	28
13.4 General Work Area	28
13.5 Checking for Presence of Refrigerant	28
13.6 Presence of Fire Extinguisher.....	28
13.7 No Ignition Sources	28
13.8 Ventilated Area	29
13.9 Checks to the Refrigerating Equipment.....	29
13.10 Checks to Electrical Devices.....	29
13.11 Pipe Installation.....	30
14 Sealed Electrical Components shall be Replaced	30
15 Intrinsically Safe Components must be Replaced	30
16 Cabling	30
17 Detection of Flammable Refrigerants	30
18 Removal and Evacuation	31
19 Charging Procedures	31
20 Decommissioning	32
21 Labeling	32
22 Recovery	32

1 Safety Notices (Please be sure to abide them)

⚠ WARNING
(1) This product can't be installed at corrosive, inflammable or explosive environment or the place with special requirements, such as kitchen. Otherwise, it will affect the normal operation or shorten the service life of the unit, or even cause fire hazard or serious injury. As for above special places, please adopt special air conditioner with anti-corrosive or anti-explosion function.
(2) Follow this instruction to complete the installation work. Please carefully read this manual before unit startup and service.
(3) Wire size of power cord should be large enough. The damaged power cord and connection wire should be replaced by exclusive cable.
(4) After connecting the power cord, please fix the electric box cover properly in order to avoid accident.
(5) Never fail to comply with the nitrogen charge requirements. Charge nitrogen when welding pipes.
(6) Never short-circuit or cancel the pressure switch to prevent unit damage.
(7) Please firstly connect the wired controller before energization, otherwise wired controller cannot be used.
(8) Before using the unit, please check if the piping and wiring are correct to avoid water leakage, refrigerant leakage, electric shock, or fire etc.
(9) Do not insert fingers or objects into air outlet/inlet grille.
(10) Open the door and window and keep good ventilation in the room to avoid oxygen deficit when the gas/oil supplied heating equipment is used.
(11) Never start up or shut off the air conditioner by means of directly plug or unplug the power cord.
(12) Turn off the unit after it runs at least five minutes; otherwise it will influence oil return of the compressor.
(13) Do not allow children operate this unit.
(14) Do not operate this unit with wet hands.
(15) Turn off the unit or cut off the power supply before cleaning the unit, otherwise electric shock or injury may happen.
(16) Never spray or flush water towards unit, otherwise malfunction or electric shock may happen.
(17) Do not expose the unit to the moist or corrosive circumstances.
(18) Under cooling mode, please don't set the room temperature too low and keep the temperature difference between indoor and outdoor unit within 5°C(41°F).
(19) User is not allowed to repair the unit. Fault service may cause electric shock or fire accidents. Please contact our designated dealer or local service center for help.
(20) Before installation, please check if the power supply is in accordance with the requirements specified on the nameplate. And also take care of the power safety.
(21) Installation should be conducted by dealer or qualified personnel. Please do not attempt to install the unit by yourself. Improper handling may result in water leakage, electric shock or fire disaster etc..
(22) Be sure to use the exclusive accessory and part to prevent the water leakage, electric shock and fire accidents.
(23) Please switch on for 8 hours before operation. Do not cut off the power when 24 hours short-time halting (to protect the compressor).
(24) If refrigerant leakage happens during installation, please ventilate immediately. Poisonous gas will emerge if the refrigerant gas meets fire.
(25) Volatile liquid, such as diluent or gas will damage the unit appearance. Only use soft cloth with a little neutral detergent to clean the outer casing of unit.
(26) If anything abnormal happens (such as burning smell), please power off the unit and cut off the main power supply, and then immediately contact our designated dealer or local service center. If abnormality keeps going, the unit might be damaged and lead to electric shock or fire.
(27) LEAK DETECTION SYSTEM installed. Unit must be powered except for service.
(28) Ducts connected to an appliance shall not contain a potential ignition source.
(29) Keep any required ventilation openings clear of obstruction.
(30) Precautions shall be taken to avoid excessive vibration or pulsation to refrigerating piping.

⚠ WARNING

- (31) Protection devices, piping and fittings shall be protected as far as possible against adverse environmental effects, for example, the danger of water collecting and freezing in relief pipes or the accumulation of dirt and debris.
- (32) Provision shall be made for expansion and contraction of long runs of piping.
- (33) Piping in refrigerating systems shall be so designed and installed to minimize the likelihood hydraulic shock damaging the system.
- (34) Steel pipes and components shall be protected against corrosion with a rustproof coating before applying any insulation.
- (35) Only auxiliary devices approved by the appliance manufacturer or declared suitable with the refrigerant shall be installed in connecting ductwork.

2 Product Introduction

2.1 Names of Key Components

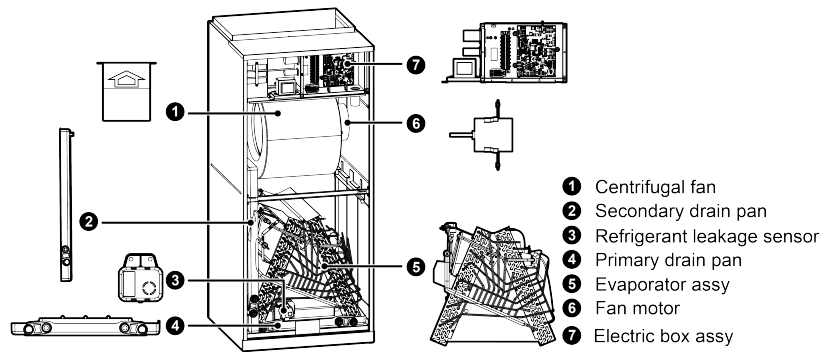

Fig.2.1.1

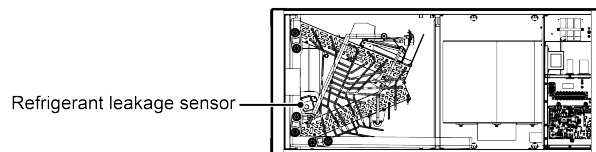

Fig.2.1.2

NOTICE

When installing as shown in the figure, the refrigerant sensor needs to be installed in the position shown in the figure, remove the fixing screws of the Refrigerant Sensor and adjust the internal wiring to ensure that the internal wiring does not touch the sharp side, the wiring cannot exceed the drip pan and the wiring must not come into contact with water.

2.2 Rated Working Condition

—	Indoor Side Condition		Outdoor Side Condition	
	Dry Bulb Temp °C(°F)	Wet Bulb Temp °C(°F)	Dry Bulb Temp °C(°F)	Wet Bulb Temp °C(°F)
Rated Cooling	26.7(80.0)	19.4(67.0)	35(95.0)	23.9(75.0)
Rated Heating	21.1(70.0)	15.6(60.0)	8.3(47.0)	6.1(43.0)

2.3 The Range of Production Working Temperature

—	Cooling	Heating
Indoor temperature	14°C(57.2°F)~25°C(77°F)WB	15°C(59°F)~27°C(80.6°F)DB
Indoor humidity	≤80%	

2.4 Minimum Room Area

Area of the room where the indoor unit is installed must meet the minimum room area in the following table:

Releasable Charge (kg)	Minimum Room Area(m ² / ft ²)					
	H ₀ ≥2.2m					
	H=2.2m	H=2.5m	H=3m	H=3.5m	H=4m	H=5m
2	6.0 / 64.0	5.3 / 56.3	4.4 / 47	3.8 / 40.3	3.3 / 35.2	2.7 / 28.2
2.2	6.6 / 70.4	5.8 / 62.0	4.8 / 51.6	4.2 / 44.3	3.6 / 38.7	2.9 / 31
2.4	7.2 / 76.8	6.3 / 67.6	5.3 / 56.3	4.5 / 48.3	4 / 42.3	3.2 / 33.8
2.6	7.8 / 83.2	6.8 / 73.2	5.7 / 61	4.9 / 52.3	4.3 / 45.8	3.4 / 36.6
2.8	8.4 / 89.6	7.4 / 78.8	6.2 / 65.7	5.3 / 56.3	4.6 / 49.3	3.7 / 39.4
3	9.0 / 96.0	7.9 / 84.5	6.6 / 70.4	5.7 / 60.4	5 / 52.8	4 / 42.3
3.2	9.6 / 102.4	8.4 / 90.1	7 / 75.1	6 / 64.4	5.3 / 56.3	4.2 / 45.1
3.4	10.2 / 108.8	8.9 / 95.7	7.5 / 79.8	6.4 / 68.4	5.6 / 59.8	4.5 / 47.9
3.6	10.7 / 115.2	9.5 / 101.4	7.9 / 84.5	6.8 / 72.4	5.9 / 63.4	4.8 / 50.7
3.8	11.3 / 121.6	10.0 / 107.0	8.3 / 89.2	7.1 / 76.4	6.3 / 66.9	5 / 53.5
4	11.9 / 128.0	10.5 / 112.6	8.8 / 93.9	7.5 / 80.5	6.6 / 70.4	5.3 / 56.3
4.2	12.5 / 134.4	11.0 / 118.2	9.2 / 98.5	7.9 / 84.5	6.9 / 73.9	5.5 / 59.1
4.4	13.1 / 140.8	11.6 / 123.9	9.6 / 103.2	8.3 / 88.5	7.2 / 77.4	5.8 / 62
4.6	13.7 / 147.2	12.1 / 129.5	10.1 / 107.9	8.6 / 92.5	7.6 / 81	6.1 / 64.8
4.8	14.3 / 153.5	12.6 / 135.1	10.5 / 112.6	9 / 96.5	7.9 / 84.5	6.3 / 67.6
5	14.9 / 159.9	13.1 / 140.8	10.9 / 117.3	9.4 / 100.6	8.2 / 88	6.6 / 70.4
5.2	15.5 / 166.3	13.6 / 146.4	11.4 / 122	9.8 / 104.6	8.5 / 91.5	6.8 / 73.2
5.4	16.1 / 172.7	14.2 / 152.0	11.8 / 126.7	10.1 / 108.6	8.9 / 95	7.1 / 76
5.6	16.7 / 179.1	14.7 / 157.6	12.3 / 131.4	10.5 / 112.6	9.2 / 98.5	7.4 / 78.8
5.8	17.3 / 185.5	15.2 / 163.3	12.7 / 136.1	10.9 / 116.6	9.5 / 102.1	7.6 / 81.7
6	17.9 / 191.9	15.7 / 168.9	13.1 / 140.8	11.3 / 120.7	9.9 / 105.6	7.9 / 84.5
6.2	18.5 / 198.3	16.3 / 174.5	13.6 / 145.4	11.6 / 124.7	10.2 / 109.1	8.2 / 87.3
6.4	19.1 / 204.7	16.8 / 180.2	14 / 150.1	12 / 128.7	10.5 / 112.6	8.4 / 90.1
6.6	19.7 / 211.1	17.3 / 185.8	14.4 / 154.8	12.4 / 132.7	10.8 / 116.1	8.7 / 92.9
6.8	20.3 / 217.5	17.8 / 191.4	14.9 / 159.5	12.7 / 136.7	11.2 / 119.6	8.9 / 95.7
7	20.8 / 223.9	18.4 / 197.0	15.3 / 164.2	13.1 / 140.8	11.5 / 123.2	9.2 / 98.5
7.2	21.4 / 230.3	18.9 / 202.7	15.7 / 168.9	13.5 / 144.8	11.8 / 126.7	9.5 / 101.4
7.4	22.0 / 236.7	19.4 / 208.3	16.2 / 173.6	13.9 / 148.8	12.1 / 130.2	9.7 / 104.2
7.6	22.6 / 243.1	19.9 / 213.9	16.6 / 178.3	14.2 / 152.8	12.5 / 133.7	10 / 107

NOTICE

- (1) H₀ is the release height, H_{inst} is the installation height, H₀ is higher than H_{inst}.
- (2) H is the floor-to-ceiling height of the room.
- (3) If the actual releasable charge is not exactly equal to the value in the table, the larger releasable charge in the table need to be taken.
- (4) If the actual H is not exactly equal to the value in the table, the smaller H in the table need to be taken.
- (5) This manual is only applicable to a single room.

- (6) Correct the minimum room area of the space A_{min} by multiplying by an altitude adjustment factor (AF) based on for building site ground level altitude (H_{alt}) in meters.

Halt	0	200	400	600	800	1000	1200	1400	1600
AF	1.00	1.00	1.00	1.00	1.02	1.05	1.07	1.10	1.12
Halt	1600	1800	2000	2200	2400	2600	2800	3000	3200
AF	1.12	1.15	1.18	1.21	1.25	1.28	1.32	1.36	1.40

- (7) The minimum airflow Q_{min} is $240m^3/h$.
- (8) LEAK DETECTION SYSTEM installed. Unit must be powered except for service.
- (9) If the air duct supplies one or more rooms, it only needs to meet $A1 + A2 + A3 >$ Minimum Room Area.

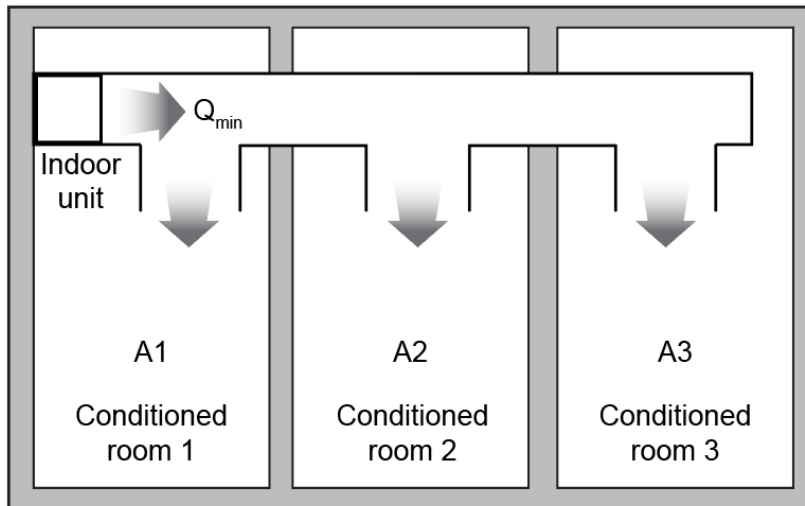

Fig.2.4.1

2.5 Calculation Method of Releasable Charge (m_{REL})

The outdoor unit is equipped with automatic refrigerant cut-off valves. When the indoor unit detects refrigerant leakage, the cut-off valves will cut off the refrigerant of the outdoor unit. The releasable charge (m_{REL}) refers to the total amount of refrigerant remaining in all indoor units and pipeline that may leak into the room.

$$m_{REL} = m1 \text{ of all indoor units in the system} + m2 \text{ of all pipeline in the system} + 0.204kg$$

If the calculated m_{REL} is larger than the system refrigerant amount (including the default refrigerant of outdoor unit and the additional refrigerant charge), the system refrigerant amount should be used as m_{REL} .

$m1$ of high pressure ducted type indoor unit is shown in the following table. $m1$ of other indoor units refer to corresponding Owner's Manual.

Unit: kg

Indoor Unit	$m1$ of single indoor unit
GMV-ND12A/NhB-T(U)	0.56
GMV-ND18A/NhB-T(U)	0.56
GMV-ND24A/NhB-T(U)	0.79
GMV-ND30A/NhB-T(U)	0.79
GMV-ND36A/NhB-T(U)	1.27
GMV-ND42A/NhB-T(U)	1.27
GMV-ND48A/NhB-T(U)	2.31
GMV-ND54A/NhB-T(U)	2.31
GMV-ND60A/NhB-T(U)	2.31

All pipelines in the system are divided into three types A/B/C according to pipe dimension. Count the total pipe length of each type and find out m2 of corresponding type in the table below. Add up all m2 of each type to obtain the m2 of the system.

m2 of pipeline:

Unit: kg

Pipe Type		A	B	C
Gas Pipe mm (inch)		15.9 (5/8)	12.7 (1/2)	9.52 (3/8)
Liquid Pipe mm (inch)		9.52 (3/8)	6.35 (1/4)	6.35 (1/4)
Total Pipe Length m (feet)	5 (16-3/8)	0.27	0.11	0.10
	10 (32-13/16)	0.54	0.22	0.20
	15 (49-3/16)	0.80	0.33	0.29
	20 (65-5/8)	1.07	0.43	0.39
	25 (82)	1.33	0.54	0.49
	30 (98-7/16)	1.60	0.65	0.58
	35 (114-13/16)	1.87	0.75	0.68
	40 (131-1/4)	2.13	0.86	0.78
	45 (147-5/8)	2.40	0.97	0.87
	50 (164-1/16)	2.66	1.07	0.97
	55 (180-7/16)	2.93	1.18	1.07
	60 (196-7/8)	3.20	1.29	1.16
	65 (213-1/4)	3.46	1.39	1.26
	70 (229-11/16)	3.73	1.50	1.36
	75 (246-1/16)	3.99	1.61	1.45
	80 (262-7/16)	4.26	1.71	1.55
	85 (278-7/8)	4.53	1.82	1.65
90 (295-1/4)	4.79	1.93	1.74	
95 (311-11/16)	5.06	2.03	1.84	
100 (328-1/16)	5.32	2.14	1.93	

NOTICE

If the actual pipe length is not exactly equal to the value in the table, the longer length in the table need to be taken.

For example:

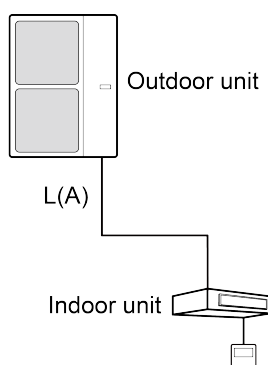

Fig.2.5.1

There are four indoor units in the system: GMV-ND60A/NhB-T(U)*1

The total length of type A pipeline L is 5m. m2 of type A is 0.27kg.

The total length of type B pipeline is 0m. m2 of type B is 0kg.

The total length of type C pipeline is 0m. m2 of type C is 0kg.

The system refrigerant amount is 3.9kg.

The releasable charge (m_{REL}) should be calculated as below:

$$m1=2.31\text{kg}$$

$$m2=0.27+0+0=0.27\text{kg}$$

$$m_{REL}=2.31\text{kg}+0.27\text{kg}+0.204\text{kg}=2.784\text{kg}$$

For 3 meters high room, the room area must not less than $6.2\text{m}^2(65.7\text{ft}^2)$. If the room area is less than $6.2\text{m}^2(65.7\text{ft}^2)$, measures need to be taken to make the room area meet the requirements, such as changing the piping design of the system to reduce the m_{REL} .

3 Preparations for Installation

NOTICE

Product graphics are only for reference. Please refer to actual products. Unspecified measure unit is mm(inch).

3.1 Pre-Installation Instruction

3.1.1 Checking Product Received

After receiving the product, please check if there is any damage caused by transportation. Shipping damage is the responsibility of the carrier. Verify the model No., specifications and accessories are correct prior to installation. The distributor or manufacturer will not accept claims from dealers for transportation damage or installation of incorrectly shipped units.

3.1.2 Before Installation

Carefully read all instructions for the installation prior to installing product. Make sure each step or procedure is understood and any special considerations are taken into account before starting installation. Assemble all tools, hardware and supplies needed to complete the installation. Some items may need to be purchased locally. Make sure everything needed to install the product is on hand before starting.

3.1.3 Codes & Regulations

This product is designed and manufactured to comply with national codes. It is installer's responsibilities to install the product in accordance with such codes and/or any prevailing local codes/regulations. The manufacturer assumes no responsibilities for equipment installed in violation of any codes or regulations.

3.1.4 Replacement Parts

When reporting shortages or damages, or ordering repair parts, give the complete product No. and serial numbers as stamped on the product. Replacement parts for this product are available through your contractor or local distributor.

3.2 Important Safety Instructions

Recognize Safety Symbols, Words, and Labels

The following symbols and labels are used throughout this manual to indicate immediate or potential hazards. It is the owner's responsibility to read and comply with all safety information and

instructions accompanying these symbols. Failure to heed safety information increases the risk of serious personal injury or death, property damage and/or product damage.

⚠ DANGER Immediate hazards which will result in property damage, product damage, severe personal injury or death.

⚠ WARNING Hazards or unsafe practice could result in property damage, product damage, severe personal injury or death.

⚠ CAUTION Hazards or unsafe practices which may result in property damage, product damage, severe personal injury or death.

⚠ WARNING Before serving or installing this equipment. The electrical power to this unit must be in the “off” position. Caution, more than one disconnect may exist. Failure to observe this warning may result in an electrical shock that can cause personal injury or death.

⚠ WARNING The United States environmental protection agency (“EPA”) has issued various regulations regarding the introduction and disposal of refrigerants introduced into this unit. Failure to follow these regulations may harm the environment and can lead to the imposition of substantial fines. These regulations may vary due to the passage of laws. A certified technician must perform the installation and service of this product. Should questions arise, contact your local EPA office.

⚠ WARNING Due to high system pressure and electrical shock in potential, installation and service work can be dangerous. Only trained and qualified personnel are permitted to install or service this equipment. Observe all warnings contained in this manual and labels/tags attached to the equipment.

⚠ WARNING This product is factory shipped for use with a 208-230/1/60 electrical power supply. This air handler must not be reconfigured to operate with any other power supply.

⚠ WARNING The unit must have an uninterrupted, unbroken electric grounding to minimize the possibility of personal injury if an electric fault occurs. The electric grounding circuit may consist of an appropriate sized power cord which connected with the grounding piece located in the unit control box and also connecting to the building electric service panel. Other methods of grounding are permitted if performed in accordance with the “national electric code” (NEC) / “American national standards institute” (ANSI) / “national fire protection association” (NFPA) 70 and local/state codes. In Canada, electric grounding conforms to the Canadian electric code CSA c22.1. Failed to observe this warning can result in electrical shock that can cause personal injury.

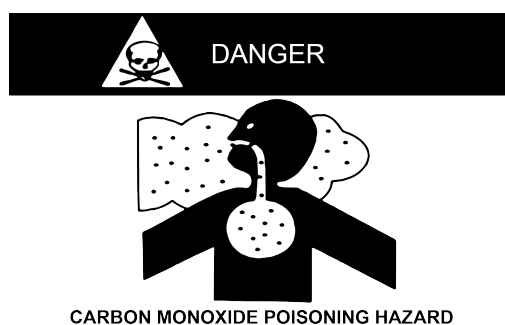

Fig.3.2.1

Special warning for installation of furnaces or air handling units in enclosed areas, such as garages, utility rooms or parking areas.

Carbon monoxide producing devices (such as an automobile, space heater, gas water heater, etc.) should not be operated in enclosed areas such as unventilated garages, utility rooms or parking areas because of the danger of carbon monoxide (CO) poisoning resulting from the exhaust emissions. If a furnace or air handler is installed in an enclosed area such as a garage, utility room or parking area and a carbon monoxide producing device is operated therein, there must be adequate ventilation directly to outside.

This ventilation is necessary to avoid the danger of CO poisoning which can occur if a carbon monoxide producing device continues to operate in the enclosed area. Carbon monoxide emission can be (re)circulated throughout the building if the furnace or air handler is operating in any mode.

CO can cause serious illness including permanent brain damage or death.

3.3 Requirements for Communication Line

NOTICE If the unit is installed in the place with strong electromagnetic interference, shielded wire must be applied on the communication wire between indoor unit and wired controller. Twisted pair line with shielding function must be applied on the communication wire between indoor unit and indoor unit (outdoor unit).

3.3.1 Select communication line for indoor unit and wired controller

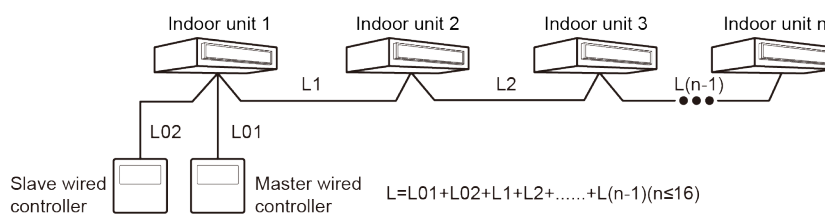

Fig.3.3.1

Wire type	Total length of communication line between indoor unit and wired controller L (m/ft.)	Numbers × size	Remarks
Light/Ordinary polyvinyl chloride sheathed cord.	$L \leq 250$ ($L \leq 820-1/4$)	2×AWG18~2×A WG16	<ol style="list-style-type: none"> Total length of communication cable can't exceed 250m (820-1/4ft.). The average length of the communication line between indoor unit and wired controller is 15m. The cord shall be Circular cord (the cores shall be twisted together). If unit is installed in places with intense magnetic field or strong interference, it is necessary to use shielded wire.

3.3.2 Select communication line for indoor unit and outdoor unit

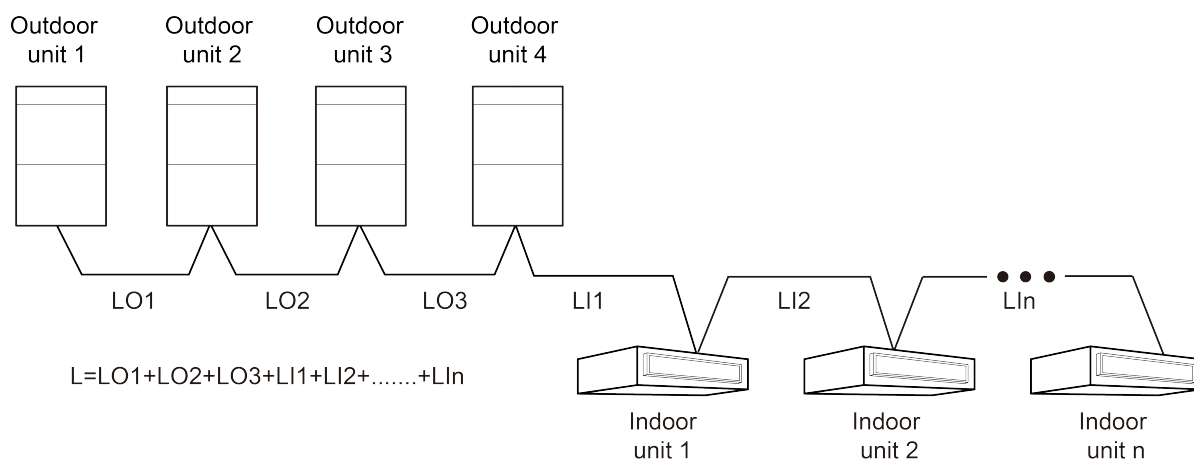

Fig.3.3.2

Wire type	Total length L (m/ft.) of communication wire between indoor unit and indoor unit (outdoor unit)	Numbers × size	Remarks
Light/Ordinary polyvinyl chloride sheathed cord.	$L \leq 1000$ ($L \leq 3280-7/8$)	$\geq 2 \times \text{AWG}18$	<ol style="list-style-type: none"> If the wire diameter is enlarged to AWG16, the total communication cable length can reach 1500m (4921-1/4ft.). The average length of communication line between units is 12.5 m. The cord shall be Circular cord (the cores shall be twisted together). If unit is installed in places with intense magnetic field or strong interference, it is necessary to use shielded wire.

3.4 Wiring Requirements and Fuse Capacity

Power Cord Size and Air Switch Capacity and Fuse Capacity

Model	Power Supply	MCA(A)	MOP(A)	Fuse Capacity(A)
GMV-ND12A/NhB-T(U)	208/230V-1ph-60Hz	2.0	15	3.15
GMV-ND18A/NhB-T(U)	208/230V-1ph-60Hz	2.0	15	3.15
GMV-ND24A/NhB-T(U)	208/230V-1ph-60Hz	3.0	15	3.15
GMV-ND30A/NhB-T(U)	208/230V-1ph-60Hz	3.0	15	3.15
GMV-ND36A/NhB-T(U)	208/230V-1ph-60Hz	4.0	15	3.15
GMV-ND42A/NhB-T(U)	208/230V-1ph-60Hz	4.0	15	3.15
GMV-ND48A/NhB-T(U)	208/230V-1ph-60Hz	7.7	15	3.15
GMV-ND54A/NhB-T(U)	208/230V-1ph-60Hz	7.7	15	3.15
GMV-ND60A/NhB-T(U)	208/230V-1ph-60Hz	7.7	15	3.15

NOTICE

- (1) Fuse is located on the main board.
- (2) Use copper wire only as unit's power cord. Operating temperature should be within its rated value.
- (3) If the power cord is more than 15m (49-1/4 ft.) long, please increase properly the sectional area of power cord to avoid overload, which may cause accident.
- (4) Above selection requirements: Power cord size is based on BV single-core wire (2~4pc) at 40°C(104°F) ambient temperature when laying across plastic pipe. Air switch is D type and used at 40°C(104°F). If actual installation condition varies, please lower the capacity appropriately according to the specifications of power cord and air switch provided by manufacturer.
- (5) Continuous air circulation required for proper functioning. Unit must be powered except for service.

4 Installation Instructions

⚠ WARNING All phases of this installation must conform to NATIONAL, STATE AND LOCAL CODES. If it is required for additional information, please contact your local distributor.

⚠ WARNING A brazed, welded, or mechanical connection shall be made before opening the valves to permit refrigerant to flow between the REFRIGERATING SYSTEM parts. A vacuum valve shall be provided to evacuate the interconnecting pipe or any uncharged REFRIGERATING SYSTEM part.

NOTICE These duct type indoor units are limited to be installed for one room.

4.1 Dimension Data

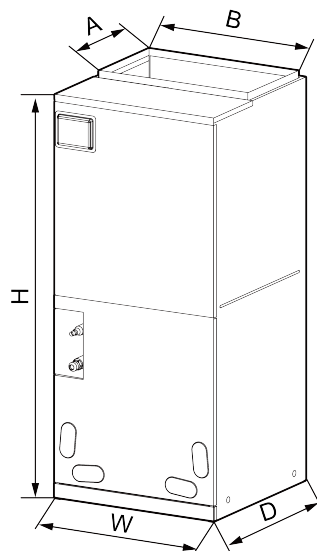

Fig.4.1.1

Unit: mm (inch)

Model	Dimension				
	W	D	H	A	B
GMV-ND30A/NhB-T(U) GMV-ND24A/NhB-T(U) GMV-ND18A/NhB-T(U) GMV-ND12A/NhB-T(U)	540 (21-1/4)	460 (18-1/8)	1105 (43-1/2)	295 (11-5/8)	426 (16-3/4)
GMV-ND42A/NhB-T(U) GMV-ND36A/NhB-T(U)	540 (21-1/4)	540 (21-1/4)	1224 (48-1/4)	295 (11-5/8)	508 (20)
GMV-ND60A/NhB-T(U) GMV-ND54A/NhB-T(U) GMV-ND48A/NhB-T(U)	630 (24-13/16)	540 (21-1/4)	1320 (51-15/16)	295 (11-5/8)	508 (20)

4.2 Location

4.2.1 Unit Inspection

Upon delivery, inspect the unit for damage. Any damage must be reported immediately to the carrier. Do not install such an equipment damaged by freight which determines the integrity and safety of the unit.

Please check the equipment model number to ensure the unit is appropriately sized for the condensing unit.

If an incorrect unit is supplied, it must not be installed and it is to be returned to the supplier. The manufacturer assumes no responsibility for the installation of incorrectly delivered units. The evaporator coil contains high-pressure inert gas for holding charge.

4.2.2 Installation Site

- ◆ A place where cool air can be distributed throughout the room.
- ◆ A place where condensation water is easily drained out.
- ◆ A place that can bear the weight of indoor unit.
- ◆ A place which is easy for maintenance.
- ◆ A place where easy connection with the outdoor unit is available.
- ◆ A place where is 1m or more away from other electric appliances such as television, audio device, etc.
- ◆ Avoid a location where there is heat source, high humidity or inflammable gas.
- ◆ Do not place the unit near a laundry, a bath, a shower or a swimming pool.
- ◆ Be sure that the installation conforms to the installation dimension diagram.
- ◆ The space around the unit is adequate for ventilation.

4.2.3 Location

⚠ WARNING This air handler is designed for indoor installation only. Do not install it outdoors.

When installing the air handler, take consideration to minimize the length of refrigerant tubing as much as possible. Do not install the air handler in a location either above or below the condenser that violates the instructions provided with the condenser. Service clearance is to take precedence. Allow a minimum of 24" in front of the unit for service clearance. When installing in an area directly over a finished ceiling (such as an attic), an emergency drain pan is required directly under the unit. See local and state codes for requirements. When installing this unit in an area that may become wet, elevate the unit with a sturdy, non-porous material. In installations that may lead to physical damage (i.e. a garage) it is advised to install a protective barrier to prevent such damage.

This air handler is designed for a complete supply and return ductwork system. These duct type indoor units are used to supply conditioned air to one room. Do not operate this product without all ductwork attached.

Based upon the actual conditions, if air handler is installed as Fig.4.2.1(A), the air handler should be concealed in a specific room or space and make sure the air handler is not accessible to the general public.

Based upon the actual conditions, if air handler is installed as Fig.4.2.1(B), make sure that there is enough space for care and maintenance and the height between the air handler and ground is above 2500mm. And the air handler is not accessible to the general public.

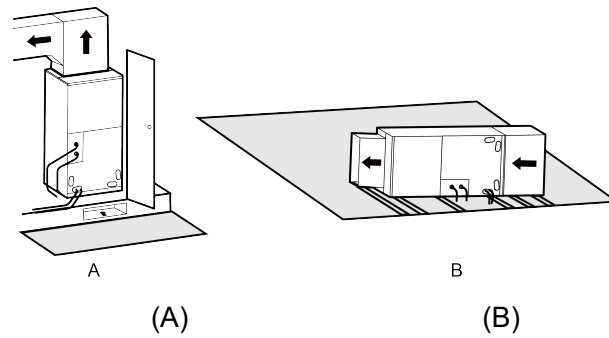

Fig.4.2.1

Measures should be reserved for easy disconnection and cleaning of the main drain pipe.

After installation, test the condensate pan and drain pipe. Pour sufficient water into the drain pan to fill the water seal and drain pipe. Check that the drain pan is completely emptied, there is no leakage at the drain pipe joints, and water is discharged from the end of the main drain pipe.

Make sure the unit is horizontal or slightly inclined towards the main drain so that the water in the drain pan can be completely drained. An additional lift of up to 1/4 inch is allowed within the width or depth of the unit to enhance the inclination to the drain. The unit must be kept between horizontal and 1/4" lift, and inclined toward the drain joint. The following figure is for reference.

Installation slope requirement 1

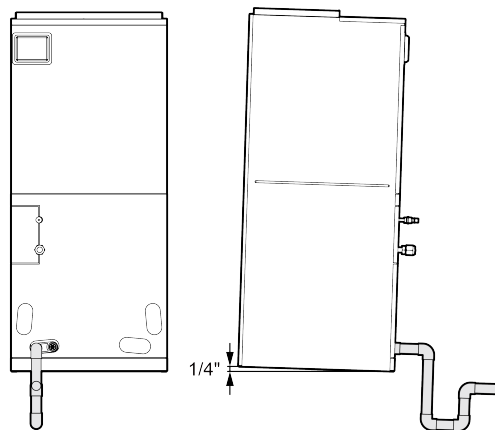

Fig.4.2.2

Installation slope requirement 2

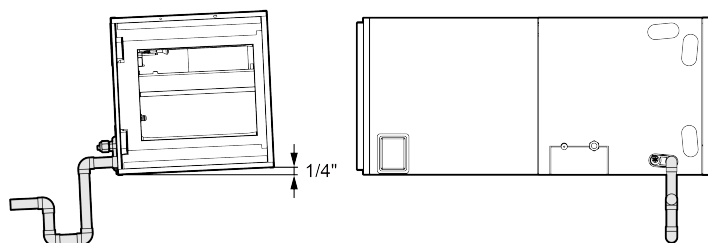

Fig.4.2.3

Installation slope requirement 3

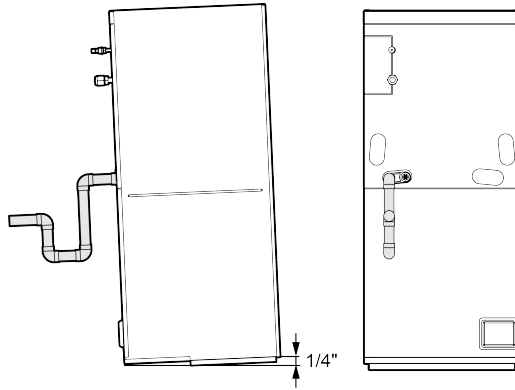

Fig.4.2.4

Installation slope requirement 4

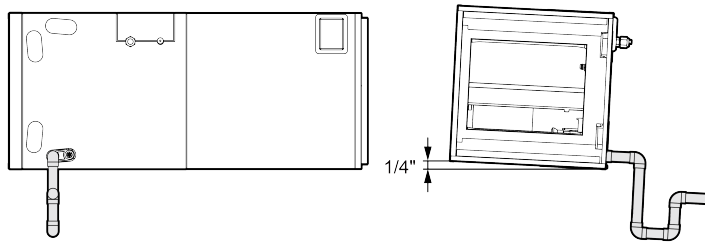

Fig.4.2.5

4.3 Piping Work

4.3.1 Specification of Connection Pipe

Unit: mm (inch)

Model	External Diameter	
	Gas Pipe	Liquid Pipe
GMV-ND12A/NhB-T(U)	9.52(3/8)	6.35(1/4)
GMV-ND18A/NhB-T(U)	12.7(1/2)	6.35(1/4)
GMV-ND24A/NhB-T(U)	12.7(1/2)	6.35(1/4)
GMV-ND30A/NhB-T(U)	15.9(5/8)	9.52(3/8)
GMV-ND36A/NhB-T(U)	15.9(5/8)	9.52(3/8)
GMV-ND42A/NhB-T(U)	15.9(5/8)	9.52(3/8)
GMV-ND48A/NhB-T(U)	15.9(5/8)	9.52(3/8)
GMV-ND54A/NhB-T(U)	15.9(5/8)	9.52(3/8)
GMV-ND60A/NhB-T(U)	15.9(5/8)	9.52(3/8)

4.3.2 Piping Preparation

4.3.2.1 Solder Connection

All cut ends are to be round, burr free, and cleaned. Failure to follow this practice increases the chances for refrigerant leakage.

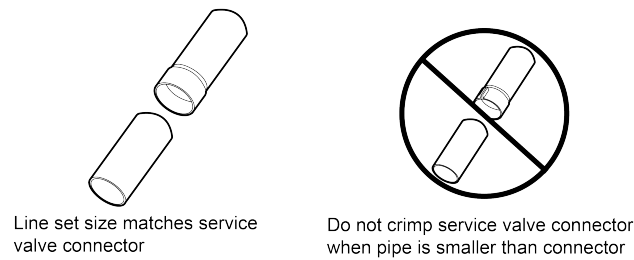

Fig.4.3.1

4.3.2.2 Screw Connection

- (1) Aim the flaring port of copper pipe at the center of screwed joint and then tighten the flaring nut with hand as shown in Fig.4.3.2
- (2) Tighten the flaring nut with torque wrench.

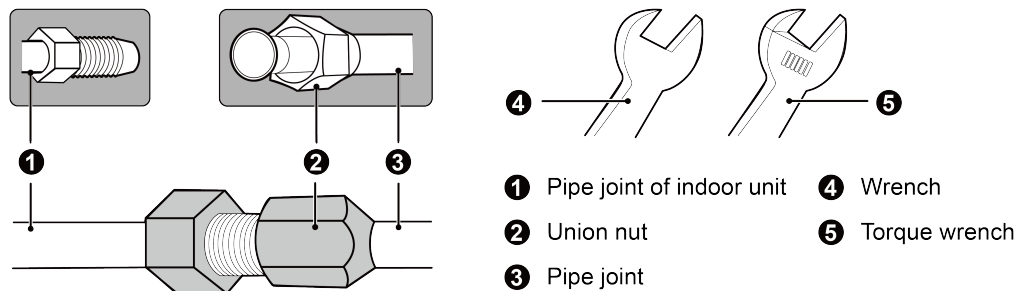

Fig.4.3.2

Pipe diameter mm(inch)	Torque(N•m)
Φ6.35(1/4)	15~30
Φ9.52(3/8)	35~40
Φ12.7(1/2)	45~50
Φ15.9(5/8)	60~65

- (3) Use pipe bend when bending the pipe and the bending angle should not be too small.
- (4) Wrap the connection pipe and joint with sponge and then tie them firmly with tape.

4.4 Condensate Removal

- (1) It is not allowed to connect the condensate drain pipe into waste pipe or other pipelines which are likely to produce corrosive or peculiar smell to prevent the smell from entering indoors or corrupt the unit.
- (2) It is not allowed to connect the condensate drain pipe into rain pipe to prevent rain water from pouring in and cause property loss or personal injury.
- (3) The unit shall be sloped at least 1/8 in./ft (10 mm/m) from the horizontal toward the drain outlet such that water drains freely from the pan whether the fan is ON or OFF.
- (4) Condensate drain pipe should be connected into special drain system for air conditioner.
- (5) The drain pan has primary and secondary drain connection. Condensate removal is performed by attaching a 3/4" PVC pipe to the evaporator coil pan and terminated in

accordance with local or state Plumbing/HVAC codes. The installation must include a trap that is located closely to the evaporator coil. Do not over-tighten the drain connection in order to prevent possible damage to the evaporator drain pan. See the following figure for details of a typical condensate line trap.

Installation of anti-back flow fitting can also be adopted; detailed information about the fitting can be obtained by contacting the contractor.

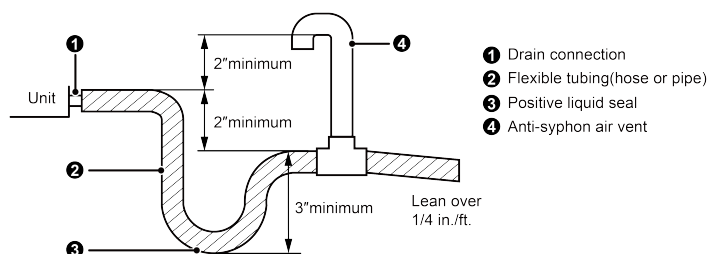

Fig.4.4.1

Anti-backflow fitting:

- (1) The vertical difference between the unit's drain pipe location and the approved drain outlet should be more than 50 cm to be suitable for installing this device;
- (2) The approved drain pipe inner diameter should be between $\Phi 25$ mm and $\Phi 50$ mm to be suitable for installation; installation is not suitable if the diameter is too large or too small;
- (3) Adjust the drain pipe length according to the actual installation conditions. The drain pipe should not be twisted, bulged, or undulated to avoid affecting drainage.
- (4) Anti-backflow fitting installation precautions:
- (5) If drain connector 1 and drain connector 2 are loose, tighten them by rotating in the direction indicated by the arrow.
- (6) Connect the air conditioner drain pipe to the upper port of drain connector 2 and insert it to the indicated position, with an insertion depth of 40 ~ 45 mm.
- (7) Use electrical tape to stick and fix the air conditioner drain pipe to drain connector 2.
- (8) After installation, insert the installed device into the approved drain and secure it with electrical tape.

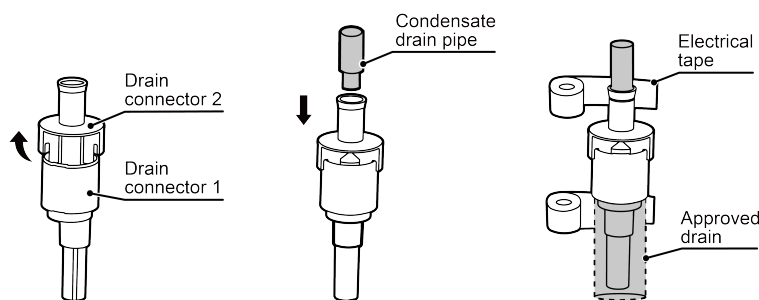

Fig.4.4.2

4.5 Installation of Wired Controller

Please refer to User Manual of Wired Controller for the installation details.

NOTICE

When installation is finished, the unit must be tested and debugged before operation. Please refer to Instruction Manual of ODU for auto addressing and debugging details.

4.6 Ductwork

This air handler is designed for a complete supply and return ductwork system.

⚠ WARNING
(1) Do not operate the unit without all ductwork completed.
(2) Do not operate this product without all ductwork attached.
(3) Inadequate ductwork that restricts airflow can result in improper performance and compressor or heater failure. Ductwork is to be constructed in a manner that limits restrictions and maintains suitable air velocity. Ductwork is to be sealed to the unit in a manner that will prevent leakage.
(4) Return ductwork: Do not terminate the return ductwork in an area that can introduce toxic, or objectionable fumes/odors into the ductwork. The return ductwork is to be introduced into the air handler bottom (up flow configuration).
(5) Return Air Filters: Each installation must include a return air filter. This filtering may be performed at the air handler or externally such as a return air filter grille.

4.7 Electric Heater

The air handlers listed in this manual do not have factory installed electric heater. Electric heater is available as an accessory. Please refer to installation instructions provided with heater kit for the correct installation procedure.

⚠ WARNING Refer to the “installing electric heater” section of this manual and the instructions provided with the heater kit for the correct installation procedure.

⚠ WARNING The electrical characteristics of the air handler, the electric heater kit, and the supply power should be identical. This air handler does not have factory installed electric heater. Electric heater is available as an accessory. If installing this option, the only heater kits that can be used are the series as indicated below. It is forbidden to use the electric heater other than those recommended.

⚠ WARNING E-HEAT mode setting method: under off status, press “/” and “MENU/OK” button for 5s to turn on or turn off E-heat mode. After that, the wired controller control pop-up box shows "Enable Setting E-Heat Mode" or "Disable Setting E-Heat Mode" for 3s, and indoor unit can set “Electric heating mode”. When E-HEAT mode has been set and indoor unit operates under heating mode, if outdoor unit stops operation because of error, indoor unit will switch to operate under electric heating mode.

⚠ WARNING After the electric heater is shutdown, the fan of indoor unit will delay for a few minutes and then shut down so that the indoor unit can blow the waste heat and relieve the heat accumulation in the air duct.

⚠ WARNING During installation and debugging, pay attention to verify the switch sequence of electric heater and fan, ensure the fan must be turned on when electric heater operation and ensure

the electric heater is turned off before the fan to avoid unsafe.

4.7.1 Electric Heater Kits Available

SN.	Kit1	Kit2	Description	Ref. air handler use(kBtu/h)
1	LYQ-08-A 5000W/240V	21-4227-01 5000W/240V	Circuit breaker, 5kW heat strip	12/18/24/30/36/42/48/54/60
2	LYQ-08-C 10000W/240V	21-4216-03 10000W/240V	Circuit breaker, 10kW heat strip	12/18/24/30/36/42/48/54/60
3	LYQ-08-D 15000W/240V	21-4217-01 15000W/240V	Circuit breaker, 15kW heat strip	36/42/48/54/60
4	LYQ-08-E 20000W/240V	21-4228-01 20000W/240V	Circuit breaker, 20kW heat strip	48/54/60

Maximum air outlet temperature 114.9°C.

4.7.2 Electric Heater Kits Installation

⚠ CAUTION

- (1) Ensure that all power supply is disconnected prior to installing the heater kit.
- (2) A means of strain relief and conductor protection must be provided at the supply wire entrance into cabinet.
- (3) Use copper conductors only.
- (4) Installation must follow national electric code and other applicable codes.
- (5) If this appliance is installed in an enclosed area such as a garage or utility room with any carbon monoxide producing appliance, ensure the area is properly ventilated.
 - 1) Refer to the Table for appropriate heater kit.
 - 2) Check any physical damage, do not install damaged heater kit.
 - 3) Remove the upper access panel from air handler.
 - 4) Remove cover plate from air handler.
 - 5) Slide the heater kit in to the slot and secure element plate with previously removed screws.
 - 6) Before installing the electric heating, unplug the X1 terminal, and insert the plug-in terminals on the electric heating to the X1 and X2 terminals respectively. The power line of the unit is connected through an electrically heated circuit breaker.
 - 7) Insert power leads into the circuit breaker lugs or stripped red and black wires (for heater kit without circuit breaker) and tighten.
 - 8) Connect ground wire to ground lug; M6 screws are required for grounding screws when installing electric heating.
 - 9) Knock off appropriate area of the plastic circuit breaker cover on the access panel of the air handler. Knock off the holes according to the actual installation number and positions of circuit breakers. If circuit breaker is not installed, do not knock off the holes; otherwise, electric shock may occur.
 - 10) Replace access panel and check operation.

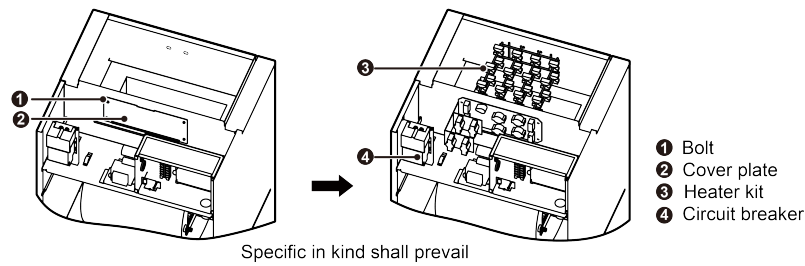

Fig.4.7.1

11) Connection of power cords and thermostat wires.

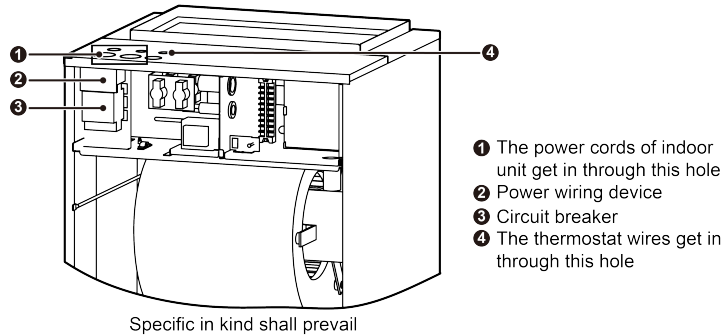

Fig.4.7.2

5 Wiring Work

⚠ WARNING

Before obtaining access to terminals, all supply circuits must be disconnected.

NOTICE

- (1) Units must be earthed securely, or it may cause electric shock.
- (2) Please carefully read the wiring diagram before carry out the wiring work, incorrect wiring could cause malfunction or even damage the unit.
- (3) The capacity of power supply must be sufficient and the sectional area of wires in the room should be above 2.5mm².
- (4) The wiring should be in accordance with related regulations in order to ensure the units reliable running.
- (5) Install circuit breaker for branch circuit according to related regulations and electrical standards.
- (6) All wiring must use pressure terminal or single wire. Multi-twisted wire that connects directly to the wiring board may cause fire hazard.
- (7) Keep cable away from refrigerant pipings, compressor and fan motor.
- (8) Do not change the internal wiring of the air conditioner; otherwise, our company will not bear relevant legal responsibilities for the related damages.
- (9) If the unit is installed in places with strong electromagnetic interference, it's recommended to use twin-twisted shield wire. During wire connection, please pay attention that the metal shield layer of the twin-twisted wire must be grounded (outer case) in order to prevent the unit from electromagnetic interference.
- (10) The communication wires should be separated from power cord and connection wire between indoor unit and outdoor unit.
- (11) The electric wire can't be expanded by connecting another electric wire. When the length of the electric wire is not enough, please contact our designated dealer or local service center for a special electric wire.
- (12) Adjust the static pressure via wired controller according to site circumstance.
- (13) Field operation and installation specifications to meet NFPA 70.

5.1 Connection of Wire and Patch Board Terminal

- (1) The connection of wire (as shown in Fig.5.1.1)
 - 1) Strip about 25mm (1inch) insulation of the wire end by stripping and cutting tool.
 - 2) Remove the wiring screws on the terminal board.
 - 3) Shape the tail of wire into ring by needle nose plier, and keep the gauge of ring in accordance with screw.
 - 4) Use the screwdriver for tightening the terminal.
- (2) The connection of stranded wire (as shown in Fig.5.1.2)
 - 1) Strip about 10mm (3/8inch) insulation of the end of stranded wire by stripping and cutting tool.
 - 2) Loosen the wiring screws on terminal board.
 - 3) Insert the wire into the ring tongue terminal and tighten by crimping tool.
 - 4) Use the screwdriver for tightening the terminal.

Unit: mm (inch)

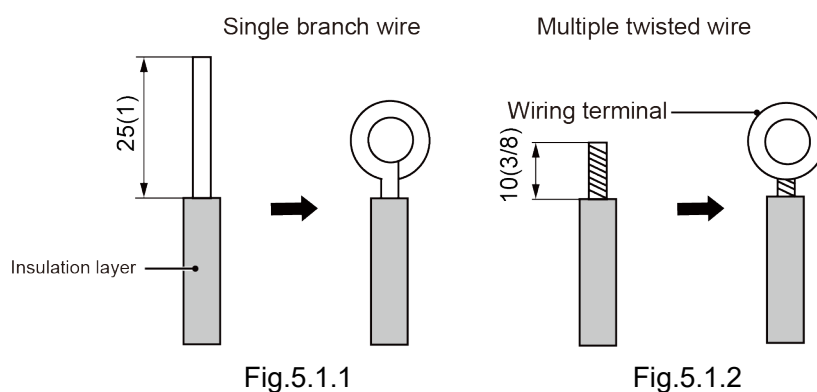

5.2 Power Cord Connection

NOTICE

- ① Every unit should be equipped with a circuit breaker for short-circuit and overload protection.
- ② During operation, all indoor units connected to the same outdoor unit system must be kept energized status. Otherwise, the unit can't operate normally.

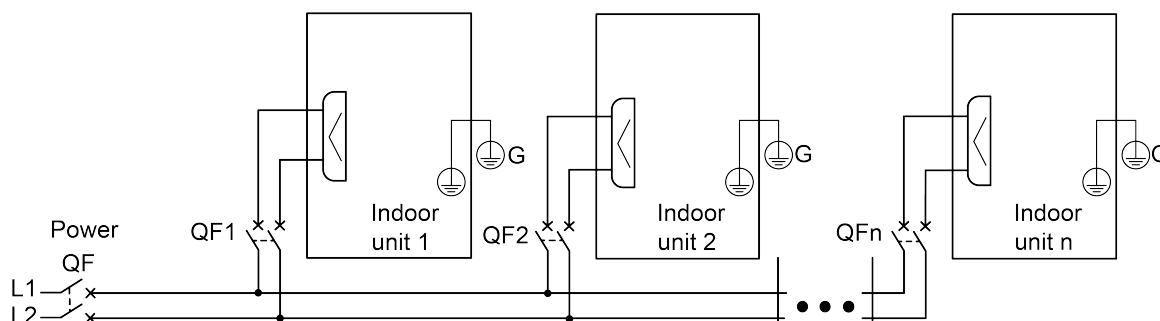

NOTICE The maximum connection quantity "n" for indoor unit is decided by the capacity of outdoor unit. Please refer to the unit capacity of unit for details.

Fig.5.2.1

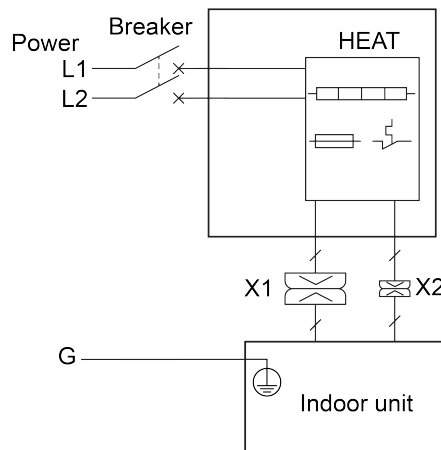

Fig.5.2.2

- (1) Detach the electric box lid.
- (2) Let the power cord pass through the wiring through-holes.
- (3) Electrical wiring of indoor units without electric heater according to Fig. 5.2.1.
- (4) Electrical wiring of indoor units with Electric Heater according to Fig. 5.2.2.
- (5) The wire diameter of power cord can't be less than 18AWG.

5.3 Connection of Communication Wire between Indoor Unit and Outdoor Unit (or indoor unit)

- (1) Detach the electric box lid.
- (2) Let the Communication cable pass through the wiring through-holes.
- (3) Connect the communication wire to terminal D1 and D2 of indoor 4-bit wiring board, as shown in Fig.5.3.1.

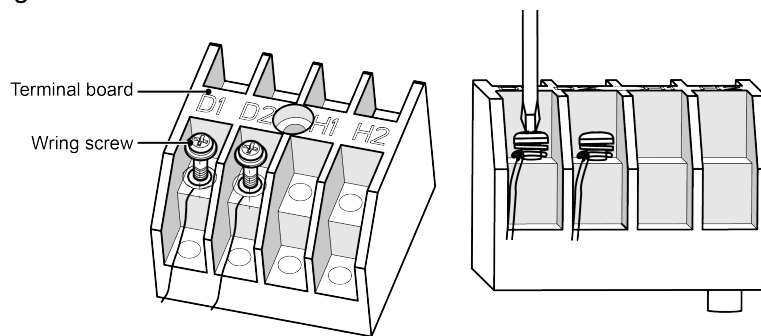
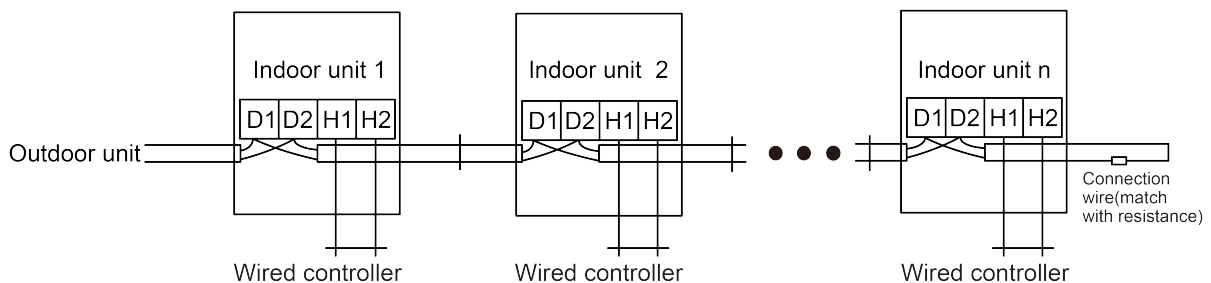

Fig.5.3.1



NOTICE Indoor unit quantity n is according to the outdoor unit capacity.

Fig.5.3.2

- (4) For more reliable communication, make sure connect the terminal resistor to the most downstream IDU of the communication bus (terminal D1 and D2), as shown in Fig.5.3.2, terminal resistor is provided with each ODU.

5.4 Connect Communication Wire of Wired Controller

- (1) Open electric box cover of indoor unit.
- (2) Let the communication wire go through the rubber ring.
- (3) Connect the communication wire to terminal H1 and H2 of indoor 4-bit wiring board.
- (4) Fix the communication wire with wire clip on the electric box.
- (5) Wiring instructions of wired controller.

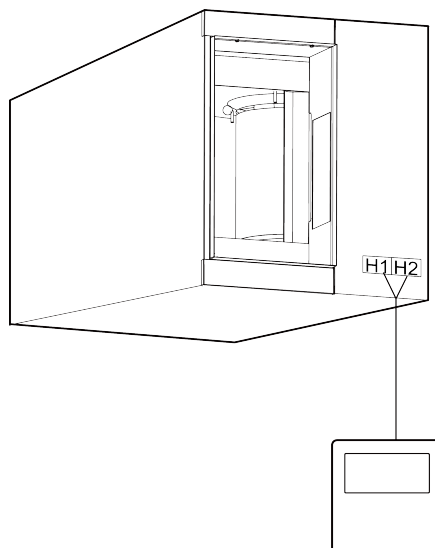

Fig.5.4.1

5.5 Illustrate for Connection of Wired Controller and Indoor Units Network

- (1) Communication wire of indoor unit and outdoor unit (or indoor unit) is connected to D1, D2.
- (2) Wired controller is connected to H1, H2.
- (3) One indoor unit can connect two wired controllers that must be set as master one and slave one.
- (4) Each indoor unit has to be connected with a R32 safety system compatible wired controller. These wired controllers have implemented safety measures that will warn the user visually and audibly in case of a leak.

NOTICE

When the indoor unit is controlled by two wired controllers, the addresses of the two wired controllers should be different through address setting. Address 1 is for main controller; Address 2 is for slave controller. Detailed setting please refer to the service manual.

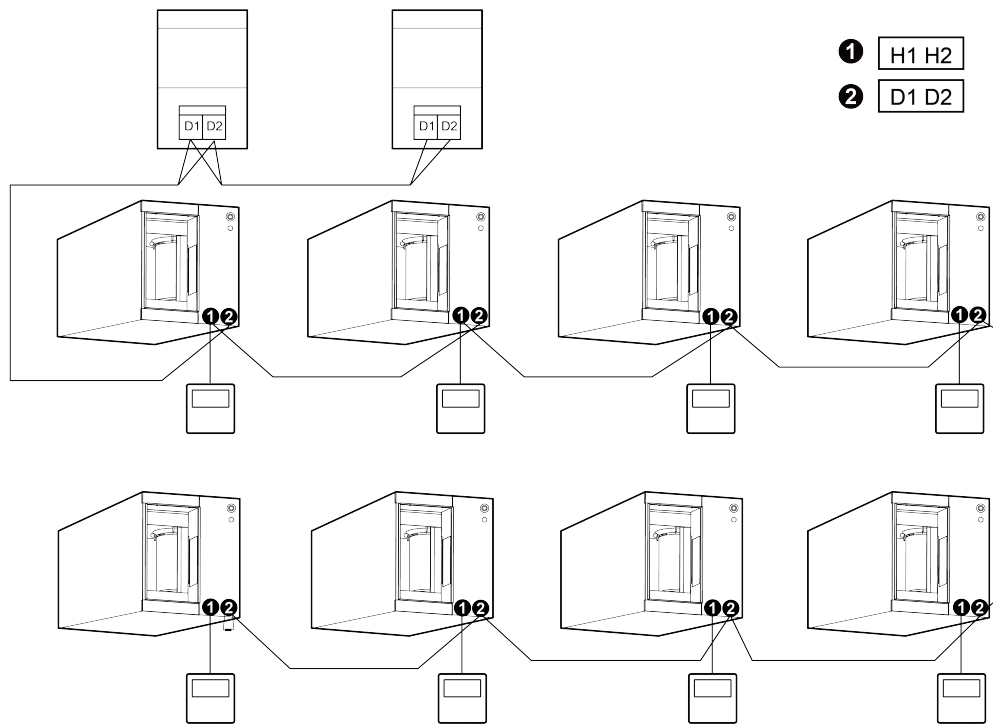

Fig.5.5.1

6 Setting of External Static Pressure

Working range for external static pressure of this series of duct type unit is 0 Pa~250 Pa. For corresponding external static pressure to the respective static pressure notch please see as below. The setting of static pressure for indoor fan can be done via wired controller and Gree debugging software. For specific setting method please see the service manual or Gree Debugging Software Instruction Manual.

Applicable to: GMV-ND12~60A/NhB-T(U)							
Static pressure notch for indoor fan	1~3	4	5	6	7	8	9
External static pressure (inwg)	0	0.08	0.20	0.40	0.60	0.80	1.00

Note: The defaulted static pressure notch for all models at ex-factory is 5.

7 Routine Maintenance

NOTICE

- (1) Do not turn off the unit and cut off the main power supply when cleaning the air conditioner to avoid electric shock or injury.
- (2) Stand at solid table when cleaning the unit.
- (3) Do not clean the unit with hot water whose temperature is higher than 45°C to prevent fade or deformation.
- (4) Do not dry the filters by fire, or it may catch fire or become deformed.
- (5) Clean the filter with a wet cloth dipped in neutral detergent.
- (6) Please contact our designated dealer or local service center if there is abnormal situation.

7.1 About the Refrigerant Leakage Sensor

- (1) The sensor has a lifetime of 15 years. At the end of lifetime or when the sensor fault, the indoor unit or wired controller displays error code “yd”, and emits an alarm sound. Measures will be taken automatically to prevent refrigerant leakage while the sensor fault.

The indoor fan will keep running to form ventilation airflow. The outdoor unit compressor will keep running for several minutes to recycle the refrigerant to the outdoor unit. Then the compressor will stop and the shut-off valves of outdoor unit will close so the refrigerant can not keep leaking.

The alarm can be canceled by operating the “On/Off” button of the wired controller or remote control. The indoor unit fan will keep running and the system can not operate until the sensor is replaced. Please contact our designated dealer or local service center to replace the sensor.

- (2) When the sensor detects refrigerant leak, the indoor unit or wired controller displays error code “yb”, and emits an alarm sound. Measures will be taken automatically to reduce the refrigerant concentration in the room.

The indoor fan will keep running to form ventilation airflow. The outdoor unit compressor will keep running for several minutes to recycle the refrigerant to the outdoor unit. Then the compressor will stop and the shut-off valves of outdoor unit will close so the refrigerant can not keep leaking.

The alarm can be canceled by operating the “On/Off” button of the wired controller or remote control. The indoor unit fan will keep running and the system can not operate until the leakage is repaired. Please contact our designated dealer or local service center.

- (3) Disassembly and installation steps of refrigerant sensor.

Disassembly:

- 1) Remove the lower front side panel.
- 2) Remove the fixing screws of the refrigerant sensor.
- 3) Replace the refrigerant sensor with a new one.
- 4) Where a single remote refrigerant sensor is used in a room with multiple units, all units in the room which do not have a dedicated refrigerant detection system shall take the same actions. When an ITE COOLING APPLIANCE or PARTIAL UNIT'S REFRIGERANT DETECTION SYSTEMS for an appliances refrigerant circuit resets to a safe condition the unit shall not be allowed to initiate NORMAL OPERATIONS until all REFRIGERANT DETECTION SYSTEM systems in the CIRCULATION AIRFLOW have been reset.

Where a single REMOTE REFRIGERANT DETECTION system sensor is used in a room with multiple units, this requirement shall apply to all units in the room which do not have a dedicated REFRIGERANT DETECTION SYSTEM.

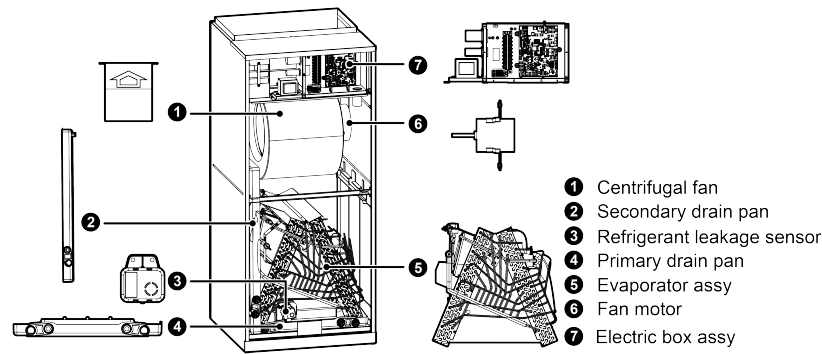

Fig.7.1.1

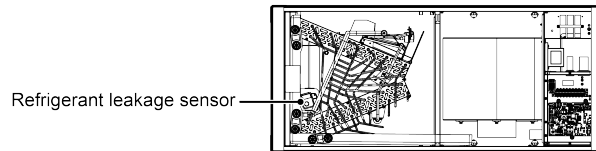

Fig.7.1.2

⚠ WARNING

- ① The R32 refrigerant leakage sensor must be replaced after malfunction or at the end of its lifetime. ONLY authorized persons may replace the sensor. Only refrigerant leakage sensor of the specified manufacturer can be used.
- ② The R32 refrigerant leakage sensor is a semiconductor detector which may incorrectly detect substances other than R32 refrigerant. Avoid using chemical substances (e.g. organic solvents, hair spray, paint) in high concentrations, in the close proximity of the indoor unit because this may cause misdetection of the R32 refrigerant leakage sensor.
- ③ High humidity environment will cause the R32 refrigerant leakage sensor fault, avoid installing indoor unit in high humidity environment or generating high temperature steam near indoor unit.

7.2 Cleaning of Filter

- (1) Remove the filters from inlet of IDU. Use a vacuum cleaner to remove dust. If the filters are dirty, wash them with warm water and mild detergent, and dry the filters in the shade.
- (2) If the unit used in the environment with much dust, please clean it regularly. (Usually once every two weeks).

7.3 Maintenance before the Seasonal Use

- (1) Check if the air inlet and air outlet of indoor and outdoor unit are blocked.
- (2) Check if securely grounded.
- (3) Check if all the power cord and communication cable are securely connected.
- (4) Check if any error code displayed after energized.

7.4 Maintenance after the Seasonal Use

- (1) Set the unit in fan mode for half a day in a sunny day to dry the inner part of unit.
- (2) When the unit won't be used for a long time, please cut off power supply for energy saving; the characters on the wired controller screen will disappear after cutting off the power

supply.

8 Table of Error Codes for Indoor Unit

Error Code	Content	Error Code	Content	Error Code	Content
L0	Indoor Unit Error	LA	Indoor Units Incompatibility Error	d9	Jumper Cap Error
L1	Indoor Fan Protection	LH	Low Air Quality Warning	dA	Indoor Unit Network Address Error
L2	E-heater Protection	LC	ODU-IDU Incompatibility Error	dH	Wired Controller PCB Error
L3	Water Full Protection	d1	Indoor Unit PCB Error	dC	Capacity DIP Switch Setting Error.
L4	Wired Controller Power Supply Error	d3	Ambient Temperature Sensor Error	dL	Outlet Air Temperature Sensor Error
L5	Freeze protection	d4	Inlet Pipe Temperature Sensor Error	dE	Indoor Unit CO ₂ Sensor Error
L7	No Master Indoor Unit Error	d6	Outlet Pipe Temperature Sensor Error	C0	Communication Error
L8	Power Insufficiency Protection	d7	Humidity Sensor Error	AJ	Filter Cleaning Reminder
L9	Quantity Of Group Control Indoor Units Setting Error	d8	Water Temperature Error	o1	Low bus bar voltage of indoor unit
o2	High bus bar voltage of indoor unit	o3	IPM Module Protection of Indoor Unit	o4	Failure Startup of Indoor Unit
o5	Overcurrent Protection of Indoor Unit	o6	Current Detection Circuit Malfunction of Indoor Unit	o7	Desynchronizing Protection of Indoor Unit
o8	Communication Malfunction of Indoor Unit's Drive	o9	Communication Malfunction of Main Mater of Indoor Unit	oA	High temperature of Indoor Unit's Module
ob	Malfunction of Temperature Sensor of Indoor Unit's Module	oC	Charging Circuit Malfunction of Indoor Unit	o0	Other Drive Malfunction
db	Special Code: Field Debugging Code	yb	Refrigerant Leakage Protection	yd	Malfunction of Refrigerant Detection Sensor
En	Malfunction of System Refrigerant Detection	—	—	—	—

9 Troubleshooting

The air conditioner is not expected to be serviced by users. Incorrect repair may cause electric shock or fire, so please contact an authorized service center for professional service. The following checks prior to contact may save your time and money.

Phenomenon	Troubleshooting
The unit can't start.	① Power supply is not connected. ② Circuit breaker tripping caused by leakage of electricity. ③ Input voltage is too low. ④ Defect of main PC-board.
The unit stops after running for a while.	① The inlet or outlet of ODU or IDU are blocked by obstacle.
Poor cooling effect.	① The filter is dirty. ② Too heavy heat load of room (e.g. too many people). ③ Door or windows is open. ④ Inlet and outlet of IDU are blocked. ⑤ Setting temperature is too high. ⑥ Refrigerant is insufficient (e.g. refrigerant leakage).
Poor heating effect.	① The filter is dirty. ② Door or window is open. ③ Setting temperature is too low. ④ Refrigerant is insufficient (e.g. refrigerant leakage).
Indoor fan doesn't start up during heating.	① At starting, the IDU fan could not operate till the heat exchange become hot, for preventing delivering the cool air. ② At defrosting, the IDU fan stopped due to system switch to cooling mode. for preventing delivering the cool air, and resume operating after defrosting.

NOTICE If air conditioner still fails to work normally after checking and handling as described above, please stop using it immediately and contact local service center for assistance.

10 Unventilated Areas

⚠ WARNING The non-FIXED APPLIANCE shall be stored in an area where the room size corresponds to the room area as specified for operation;

⚠ WARNING The non-FIXED APPLIANCE shall be stored in a room without continuously operating open flames (for example an operating gas appliance) or other POTENTIAL IGNITION SOURCES (for example an operating electric heater, hot surfaces);

⚠ WARNING If appliances with A2L REFRIGERANTS connected via an air duct system to one or more rooms are installed in a room with an area less than A_{min} , that room shall be without continuously operating open flames (for example an operating gas appliance) or other POTENTIAL IGNITION SOURCES (for example an operating electric heater, hot surfaces). A flame-producing device may be installed in the same space if the device is provided with an effective flame arrest;

⚠ WARNING Auxiliary devices which may be a POTENTIAL IGNITION SOURCE shall not be installed in the duct work. Examples of such POTENTIAL IGNITION SOURCES are hot surfaces with a temperature exceeding 648°C and electric switching devices;

⚠ WARNING That only auxiliary devices approved by the appliance manufacturer or declared suitable with the refrigerant shall be installed in connecting ductwork. The manufacturer can list in the instructions all approved auxiliary devices by the manufacturer and model number for use with the specific appliance, if those devices have a potential to become an ignition source.

11 Qualification of Worker

The manual shall contain specific information about the required qualification of the working personnel for maintenance, service and repair operations. Every working procedure that affects safety means shall only be carried out by competent persons. The training of these procedures is carried out by national training organizations or manufacturers that are accredited to teach the relevant national competency standards that may be set in legislation. The achieved competence should be documented by a certificate.

Examples for such working procedures are:

- (1) breaking into the refrigerating circuit;
- (2) opening of sealed components;
- (3) opening of ventilated enclosures.

12 Transportation, Marking and Storage for Units that Employ Flammable Refrigerants

12.1 General

The following information is provided for units that employ FLAMMABLE REFRIGERANTS.

12.2 Transport of Equipment Containing Flammable Refrigerants

Attention is drawn to the fact that additional transportation regulations may exist with respect to equipment containing flammable gas. The maximum number of pieces of equipment or the configuration of the equipment permitted to be transported together will be determined by the applicable transport regulations.

12.3 Marking of Equipment Using Signs

Signs for similar appliances used in a work area are generally addressed by local regulations and give the minimum requirements for the provision of safety and/ or health signs for a work location.

All required signs are to be maintained and employers should ensure that employees receive suitable and sufficient instruction and training on the meaning of appropriate safety signs and the actions that need to be taken in connection with these signs.

The effectiveness of signs should not be diminished by too many signs being placed together.

Any pictograms used should be as simple as possible and contain only essential details.

12.4 Disposal of Equipment Using Flammable Refrigerants

See national regulations.

12.5 Storage of Equipment/Appliances

The storage of the appliance should be in accordance with the applicable regulations or

instructions, whichever is more stringent.

12.6 Storage of Packed (Unsold) Equipment

Storage package protection should be constructed in such a way that mechanical damage to the equipment inside the package will not cause a leak of the REFRIGERANT CHARGE.

The maximum number of pieces of equipment permitted to be stored together will be determined by local regulations.

13 Information on Servicing

13.1 General

The manual shall contain specific information for service personnel according to 13.2 to 13.10.

13.2 Checks to the Area

Prior to beginning work on systems containing FLAMMABLE REFRIGERANTS, safety checks are necessary to ensure that the risk of ignition is minimized. For repair to the REFRIGERATING SYSTEM, 13.3 to 13.7 shall be completed prior to conducting work on the system.

13.3 Work Procedure

Work shall be undertaken under a controlled procedure so as to minimize the risk of a flammable gas or vapor being present while the work is being performed.

13.4 General Work Area

All maintenance staff and others working in the local area shall be instructed on the nature of work being carried out. Work in confined spaces shall be avoided.

13.5 Checking for Presence of Refrigerant

The area shall be checked with an appropriate refrigerant detector prior to and during work, to ensure the technician is aware of potentially toxic or flammable atmospheres. Ensure that the leak detection equipment being used is suitable for use with all applicable refrigerants, i.e. non-sparking, adequately sealed or intrinsically safe.

13.6 Presence of Fire Extinguisher

If any hot work is to be conducted on the refrigerating equipment or any associated parts, appropriate fire extinguishing equipment shall be available to hand. Have a dry powder or CO₂ fire extinguisher adjacent to the charging area.

13.7 No Ignition Sources

No person carrying out work in relation to a REFRIGERATING SYSTEM which involves exposing any pipe work shall use any sources of ignition in such a manner that it may lead to the risk of fire or explosion. All possible ignition sources, including cigarette smoking, should be kept sufficiently far away from the site of installation, repairing, removing and disposal, during which refrigerant can possibly be released to the surrounding space. Prior to work taking place, the area around the equipment is to be surveyed to make sure that there are no flammable hazards or ignition risks. "No

Smoking” signs shall be displayed.

13.8 Ventilated Area

Ensure that the area is in the open or that it is adequately ventilated before breaking into the system or conducting any hot work. A degree of ventilation shall continue during the period that the work is carried out. The ventilation should safely disperse any released refrigerant and preferably expel it externally into the atmosphere.

13.9 Checks to the Refrigerating Equipment

Where electrical components are being changed, they shall be fit for the purpose and to the correct specification. At all times the manufacturer’s maintenance and service guidelines shall be followed. If in doubt, consult the manufacturer’s technical department for assistance. The following checks shall be applied to installations using FLAMMABLE REFRIGERANTS:

- (1) The actual REFRIGERANT CHARGE is in accordance with the room size within which the refrigerant containing parts are installed;
- (2) The ventilation machinery and outlets are operating adequately and are not obstructed;
- (3) If an indirect refrigerating circuit is being used, the secondary circuit shall be checked for the presence of refrigerant;
- (4) Marking to the equipment continues to be visible and legible. Markings and signs that are illegible shall be corrected;
- (5) Refrigerating pipe or components are installed in a position where they are unlikely to be exposed to any substance which may corrode refrigerant containing components, unless the components are constructed of materials which are inherently resistant to being corroded or are suitably protected against being so corroded.

13.10 Checks to Electrical Devices

Repair and maintenance to electrical components shall include initial safety checks and component inspection procedures. If a fault exists that could compromise safety, then no electrical supply shall be connected to the circuit until it is satisfactorily dealt with. If the fault cannot be corrected immediately but it is necessary to continue operation, an adequate temporary solution shall be used. This shall be reported to the owner of the equipment so all parties are advised. Initial safety checks shall include:

- (1) That capacitors are discharged: this shall be done in a safe manner to avoid possibility of sparking;
- (2) That no live electrical components and wiring are exposed while charging, recovering or purging the system;
- (3) That there is continuity of earth bonding.

WARNING

Only auxiliary devices approved by the appliance manufacturer or declared suitable with the refrigerant shall be installed in connecting ductwork for duct connected appliances, false ceilings or drop ceilings may be used as a return air plenum if a REFRIGERANT DETECTION SYSTEM is

provided in the appliance and any external connections are also provided with a sensor immediately below the return air plenum duct joint.

13.11 Pipe Installation

That pipe-work including piping material, pipe routing, and installation shall include protection from physical damage in operation and service, and be in compliance with national and local codes and standards, such as ASHRAE 15, ASHRAE 15.2, IAPMO Uniform Mechanical Code, ICC International Mechanical Code, or CSA B52. All field joints shall be accessible for inspection prior to being covered or enclosed.

That after completion of field piping for split systems, the field pipework shall be pressure tested with an inert gas and then vacuum tested prior to refrigerant charging, according to the following requirements field-made refrigerant joints indoors shall be tightness tested. The test method shall have a sensitivity of 5 grams per year of refrigerant or better under a pressure of at least 0,25 times the maximum allowable pressure. No leak shall be detected.

The minimum test pressure for the low side of the system shall be the low side design pressure and the minimum test pressure for the high side of the system shall be the high side design pressure, unless the high side of the system, cannot be isolated from the low side of the system in which case the entire system shall be pressure tested to the low side design pressure.

14 Sealed Electrical Components shall be Replaced

15 Intrinsically Safe Components must be Replaced

16 Cabling

Check that cabling will not be subject to wear, corrosion, excessive pressure, vibration, sharp edges or any other adverse environmental effects. The check shall also take into account the effects of aging or continual vibration from sources such as compressors or fans.

17 Detection of Flammable Refrigerants

Under no circumstances shall potential sources of ignition be used in the searching for or detection of refrigerant leaks. A halide torch (or any other detector using a naked flame) shall not be used.

The following leak detection methods are deemed acceptable for all refrigerant systems.

Electronic leak detectors may be used to detect refrigerant leaks but, in the case of FLAMMABLE REFRIGERANTS, the sensitivity may not be adequate, or may need re-calibration. (Detection equipment shall be calibrated in a refrigerant-free area.) Ensure that the detector is not a potential source of ignition and is suitable for the refrigerant used. Leak detection equipment shall be set at a percentage of the LFL of the refrigerant and shall be calibrated to the refrigerant employed, and the appropriate percentage of gas (25 % maximum) is confirmed.

Leak detection fluids are also suitable for use with most refrigerants but the use of detergents containing chlorine shall be avoided as the chlorine may react with the refrigerant and corrode the copper pipe-work.

NOTICE Examples of leak detection fluids are:

- (1) Bubble method.
- (2) Fluorescent method agents.

If a leak is suspected, all naked flames shall be removed/extinguished.

If a leakage of refrigerant is found which requires brazing, all of the refrigerant shall be recovered from the system, or isolated (by means of shut off valves) in a part of the system remote from the leak. Removal of refrigerant shall be according to Clause 18.

18 Removal and Evacuation

When breaking into the refrigerant circuit to make repairs-or for any other purpose -conventional procedures shall be used. However, for flammable refrigerants it is important that best practice be followed, since flammability is a consideration. The following procedure shall be adhered to: The refrigerant charge shall be recovered into the correct recovery cylinders if venting is not allowed by local and national codes. For appliances containing flammable refrigerants, the system shall be purged with oxygen-free nitrogen to render the appliance safe for flammable refrigerants. This process might need to be repeated several times.

- safely remove refrigerant following local and national regulations;
- evacuate;
- purge the circuit with inert gas (optional for A2L);
- evacuate (optional for A2L);
- continuously flush or purge with inert gas when using flame to open circuit;

and

- open the circuit. Compressed air or oxygen shall not be used for purging refrigerant systems.

For appliances containing flammable refrigerants, refrigerants purging shall be achieved by breaking the vacuum in the system with oxygen-free nitrogen and continuing to fill until the working pressure is achieved, then venting to atmosphere, and finally pulling down to a vacuum (optional for A2L). This process shall be repeated until no refrigerant is within the system (optional for A2L). When the final oxygen-free nitrogen charge is used, the system shall be vented down to atmospheric pressure to enable work to take place.

The outlet for the vacuum pump shall not be close to any potential ignition sources, and ventilation shall be available.

19 Charging Procedures

In addition to conventional charging procedures, the following requirements shall be followed.

- (1) Ensure that contamination of different refrigerants does not occur when using charging equipment.
- (2) Hoses or lines shall be as short as possible to minimize the amount of refrigerant contained in them.
- (3) Cylinders shall be kept in an appropriate position according to the instructions.
- (4) Ensure that the REFRIGERATING SYSTEM is earthed prior to charging the system with refrigerant.
- (5) Label the system when charging is complete (if not already).

- (6) Extreme care shall be taken not to overfill the REFRIGERATING SYSTEM.

Prior to recharging the system, it shall be pressure-tested with the appropriate purging gas. The system shall be leak-tested on completion of charging but prior to commissioning. A follow up leak test shall be carried out prior to leaving the site.

20 Decommissioning

Before carrying out this procedure, it is essential that the technician is completely familiar with the equipment and all its detail. It is recommended good practice that all refrigerants are recovered safely.

Prior to the task being carried out, an oil and refrigerant sample shall be taken in case analysis is required prior to re-use of recovered refrigerant. It is essential that electrical power is available before the task is commenced.

- (1) Become familiar with the equipment and its operation
- (2) Isolate system electrically.
- (3) Before attempting the procedure, ensure that:
 - 1) Mechanical handling equipment is available, if required, for handling refrigerant cylinders;
 - 2) All personal protective equipment is available and being used correctly;
 - 3) The recovery process is supervised at all times by a competent person;
 - 4) Recovery equipment and cylinders conform to the appropriate standards.
- (4) Pump down refrigerant system, if possible.
- (5) If a vacuum is not possible, make a manifold so that refrigerant can be removed from various parts of the system.
- (6) Make sure that cylinder is situated on the scales before recovery takes place.
- (7) Start the recovery machine and operate in accordance with instructions.
- (8) Do not overfill cylinders (no more than 80% volume liquid charge).
- (9) Do not exceed the maximum working pressure of the cylinder, even temporarily.
- (10) When the cylinders have been filled correctly and the process completed, make sure that the cylinders and the equipment are removed from site promptly and all isolation valves on the equipment are closed off.
- (11) Recovered refrigerant shall not be charged into another REFRIGERATING SYSTEM unless it has been cleaned and checked.

21 Labeling

Equipment shall be labeled stating that it has been decommissioned and emptied of refrigerant. The label shall be dated and signed. For appliances containing FLAMMABLE REFRIGERANTS, ensure that there are labels on the equipment stating the equipment contains FLAMMABLE REFRIGERANT.

22 Recovery

When removing refrigerant from a system, either for servicing or decommissioning, it is recommended good practice that all refrigerants are removed safely.

When transferring refrigerant into cylinders, ensure that only appropriate refrigerant recovery cylinders are employed. Ensure that the correct number of cylinders for holding the total system charge is available. All cylinders to be used are designated for the recovered refrigerant and labeled for that refrigerant (i.e. special cylinders for the recovery of refrigerant). Cylinders shall be complete with pressure-relief valve and associated shut-off valves in good working order. Empty recovery cylinders are evacuated and, if possible, cooled before recovery occurs.

The recovery equipment shall be in good working order with a set of instructions concerning the equipment that is at hand and shall be suitable for the recovery of the flammable refrigerant. If in doubt, the manufacturer should be consulted. In addition, a set of calibrated weighing scales shall be available and in good working order. Hoses shall be complete with leak-free disconnect couplings and in good condition.

The recovered refrigerant shall be processed according to local legislation in the correct recovery cylinder, and the relevant waste transfer note arranged. Do not mix refrigerants in recovery units and especially not in cylinders. If compressors or compressor oils are to be removed, ensure that they have been evacuated to an acceptable level to make certain that flammable refrigerant does not remain within the lubricant. The compressor body shall not be heated by an open flame or other ignition sources to accelerate this process. When oil is drained from a system, it shall be carried out safely.

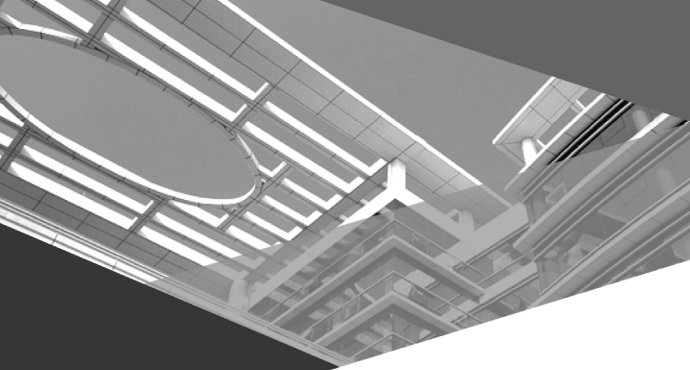

GREE ELECTRIC APPLIANCES, INC. OF ZHUHAI

Add: West Jinji Rd, Qianshan, Zhuhai, Guangdong, China, 519070

Tel: (+86-756) 8522218

Fax: (+86-756) 8669426

E-mail: global@cn.gree.com www.gree.com



600005069035